

# **Hypertherm<sup>®</sup>**

## **HyPrecision<sup>™</sup> 100D**

## **HyPrecision<sup>™</sup> 150D**



Instruction Manual

Original instructions

808310 | Revision A | English

***HyPrecision* 100D**  
***HyPrecision* 150D**

**Instruction Manual**

**808310 – Revision A**

**English**

**March 2014**

**Hypertherm Inc.  
Hanover, NH 03755 USA**

<b>1</b>	<b>Introduction .....</b>	<b>3</b>
1.1	Company Overview and Contact Information .....	3
1.2	System Overview .....	3
1.3	Definitions .....	4
<b>2</b>	<b>Safety.....</b>	<b>5</b>
2.1	General Safety.....	5
2.2	Safety Symbols .....	5
2.3	Operation and Maintenance Safety.....	6
2.4	Emergency Medical Treatment.....	9
<b>3</b>	<b>Installation.....</b>	<b>11</b>
3.1	Installation Overview.....	11
3.2	Utility Requirements.....	11
<b>4</b>	<b>Operation.....</b>	<b>15</b>
4.1	Operation Overview.....	15
4.2	Front Control Panel.....	15
4.3	Pump Startup.....	17
4.4	Pump Operation .....	19
<b>5</b>	<b>Electrical System.....</b>	<b>23</b>
5.1	Electrical System Overview.....	23
5.2	Electrical Control Panel .....	23
5.3	Motors.....	27
5.4	System Fault Detection.....	29
<b>6</b>	<b>Low-pressure Water System.....</b>	<b>33</b>
6.1	Low-pressure Water Overview .....	33
6.2	Inlet Cutting Water Supply .....	33
6.3	Cooling Water Loop (Not all Models).....	36
<b>7</b>	<b>High-pressure Water System .....</b>	<b>37</b>
7.1	High-pressure Water Overview .....	37
7.2	Intensifier.....	38
7.3	High-Pressure Ends.....	38
7.4	Check Valve Assembly.....	41
7.5	Hydraulic Seal Housing .....	44
7.6	Hydraulic Center Section.....	45
7.7	Intensifier Cycling .....	47
7.8	Pump Bleed-Down Valve .....	48
7.9	Attenuator .....	49
7.10	High-Pressure Filter Assembly (Optional).....	49
7.11	High-Pressure Plumbing Weep Holes .....	50
<b>8</b>	<b>Hydraulic System .....</b>	<b>51</b>
8.1	Hydraulic Oil .....	51
8.2	Control Manifold .....	53
8.3	Oil Filter.....	54
8.4	Heat Exchanger.....	54

8.5	Hydraulic Tank .....	55
8.6	Main Pump Setup.....	55
<b>9</b>	<b>Specifications.....</b>	<b>57</b>
9.1	Pump Requirements .....	57
9.2	Pump Capabilities .....	60
9.3	Orifice Combinations.....	60
9.4	Inlet Cutting Water Requirements .....	60
9.5	Water Treatment Guidelines: .....	61
9.6	Torque Specifications .....	62
<b>10</b>	<b>Maintenance &amp; Troubleshooting.....</b>	<b>63</b>
10.1	Parts and Service Contact Information .....	63
10.2	Maintenance Guidelines .....	63
10.3	Troubleshooting.....	65
10.4	Maintenance Log .....	69
<b>11</b>	<b>Drawings &amp; Parts Lists .....</b>	<b>71</b>
<b>12</b>	<b>Controls Manual .....</b>	<b>73</b>

# 1 Introduction

---

## 1.1 Company Overview and Contact Information

### Our Mission

To contribute to the waterjet community through the engineering, manufacturing, and sale of high quality waterjet products that lower the operating cost as an alternative to costly laser and plasma cutting.

We take pride in being a company that is recognized for its honesty, integrity, and personal service.

We strive for the greatest reliability and quality in our products and technical support.

### The Company

Hypertherm is a waterjet supply company with a history of providing economical solutions for a broad range of customers through the engineering, manufacturing, and sale of quality products and parts.

Hypertherm's rapid shift to the forefront of the waterjet industry can be attributed to our product reliability and an unyielding focus on customer feedback and support. Hypertherm has quickly earned a reputation for superior customer satisfaction and unparalleled service from a well-trained customer and technical support staff.

### History

Hypertherm's background in waterjets started in the mid-1980s with the development, application, and sale of waterjet products for a major equipment manufacturer. In the late 1990s Hypertherm was started with the goal of supplying quality spare parts and innovative products to help waterjet users lower their operating cost. Today, the company has become the leading source for industrial waterjet products.

### Customer & Technical Service

At Hypertherm, your purchase is only the beginning of our commitment to help you succeed. We believe that what happens after the sale is just as important as what happens before.

Customer Service Representatives are available to take your calls Monday through Friday 8:00 AM to 5:00 PM CST. If you need service after-hours Hypertherm is also on-call 24 hours a day, 7 days a week to ensure your system is up and running around the clock.

For more information, please call Customer Service toll-free at 866-566-7099.

## 1.2 System Overview

### Introduction

#### Pump Identification Form

**Hypertherm SERIAL NUMBER** \_\_\_\_\_

For additional copies of this manual and/or other assistance, please contact:

Hypertherm, Inc.

309 5th Ave NW

New Brighton, MN 55112

+1 651-294-8600

## **1.3 Definitions**

**LP water:** Low-pressure water that is supplied to the intensifier for pressurizing.

**HP water:** High-pressure water that is directed to the tool after being pressurized by the intensifier assembly.

**Coolant water:** Water that is circulated through the heat exchanger for cooling the hydraulic fluid.

**Pump:** A HyPrecision pump.

**ID:** Inside diameter.

**RPC:** Remote Pump Control allows operation of the pump from a remote control source.

**OCS:** Operator Control Station.

## 2 Safety

---

### 2.1 General Safety

This section describes the hazards specifically related to the operation and maintenance of HyPrecision 100D/150D Intensifier Pumps. These precautions must be reviewed and understood by operating and maintenance personnel before installing, operating or servicing the equipment.

The comprehensive list of safety precautions listed in this manual must be followed to ensure safe operation of the equipment. The safety guidelines found in this manual are general and cannot cover every possible situation; only thorough knowledge of the equipment can provide optimum safety.

Readers are expected to know how to use common hand tools safely, as well as the basic techniques for safe operation of pressure-producing equipment.



**WARNING**

**Always remember that the waterjet stream is a cutting tool! The force of a waterjet can penetrate and cut through almost any material.**

Service procedures in this manual will include safety warnings, cautions, and notes that must be read and understood.

The following symbols are used throughout the manual to bring the reader's attention to known hazards and conditions, which can be avoided. Although an attempt to point out most conditions was made, Hypertherm acknowledges that there are other unforeseen situations due to site variability, improper maintenance, etc. that could also potentially cause equipment damage, severe injury, or death. It is the end user's responsibility to identify these additional hazards and take necessary steps to minimize risks.

### 2.2 Safety Symbols

#### Warnings, cautions, and notes



**WARNING**

**Always avoid contact with the stream of water. Abrasive waterjets expel a mixture of water and abrasive that, if contact is made with skin, may be injected into the skin leading to a serious infection. Seek immediate surgical attention if you encounter any high-pressure stream of fluid.**



**WARNING**

**Indicates the presence of a hazard, which can cause severe personal injury, death, and/or substantial property damage if the warning instruction is ignored.**



**CAUTION**

**Highlights important instructions, which must be followed to prevent personal injury and/or equipment damage.**



**IMPORTANT**

Draws attention to items of important factual or procedural significance. Failure to follow the instructions may result in equipment damage.



Hazardous voltage within can cause injury or death. Disconnect and lock out main power before opening the cabinet.



High-pressure waterjet can cause eye injury. Wear eye protection when operating or working near the machine.



Wear ear protection when operating or working near the machine to reduce the risk of hearing loss.



Airborne contaminants or suspended particles may exist when cutting certain materials. Wear respiratory protection when these conditions are present.

## 2.3 Operation and Maintenance Safety

Read and understand the **Operation** section of this manual before operating the equipment. People who have not been trained in the safe operation of this waterjet machine should not be allowed near the system.

- Always wear safety glasses when working on or near the pump.
- Clean and inspect equipment regularly and fix all problems immediately.
- The operation and maintenance of this system should only be performed by trained, qualified personnel.
- Ensure that all personnel not involved in operating the machine are a safe distance from the equipment.
- Keep the work area clean and free of water or fluid spills.

### Operating Safety

Failure to wear proper safety gear can result in personal injury or death. Safety shoes, hardhat, hearing protection, and other personal protective equipment are strongly recommended.



High-pressure waterjet can cause eye injury. Wear eye protection when operating or working near the machine.



Wear ear protection when operating or working near the machine to reduce the risk of hearing loss.





Airborne contaminants or suspended particles may exist when cutting certain materials. Wear respiratory protection when these conditions are present.

## Maintenance Safety

- Read the instructions in all sections of this manual before performing any maintenance on the pump. Important information is contained throughout this manual to minimize hazards and wear on the machine.



### WARNING

Before starting any service or maintenance, turn off electrical power and relieve all water and hydraulic pressure. Proper lockout/tag-out procedures must always be followed prior to performing any maintenance of the unit.

- Use the proper tools required for specific procedures. When special tools are called for, make sure to use them because they are specifically designed to make the job easier and prevent damage to the equipment.
- Remove all tools from the work area before starting the machine.
- Always test the pump after service or maintenance: follow startup procedures outlined in the **Operation** section of this manual.

## Electrical System Safety

- Always make certain the electrical current is shut off and the proper lockout/tag-out procedures have been followed before starting any service or maintenance procedures.



Hazardous voltage within can cause injury or death. Disconnect and lock out main power before opening the cabinet.

- Make sure that all safety devices are operational.
- To panic-stop the pump and bleed the high pressure, push in the **EMERGENCY STOP** button.
- Open the main power circuit breaker (plant-supplied power) before beginning the procedure. Attach a safety tag warning others not to turn the power on.
- When replacing wiring, use only the same size, type, and color as the original.
- After servicing, ensure all electrical breakers are reconnected and doors and covers are closed before restarting.
- To check emergency system: turn on power and push the **EMERGENCY STOP** button(s). Check the system to make sure it has been shut down properly.

## High-Pressure Water System Safety

Never work on any high-pressure component or loosen any high-pressure fittings without first bleeding the system to ensure that there is no high-pressure water present. Follow all instructions and safety recommendations in this manual.



**WARNING**

**Always avoid contact with the stream of water. Seek immediate surgical attention if you are exposed to any high-pressure stream of fluid.**

- Avoid contact with the high-pressure water. HP water can penetrate any part of the human body and cause severe infection or death if not treated properly. Seek immediate surgical attention if you come in contact with any high pressure stream of fluid.
- Do not try to repair a leak on any HP water fitting when the system is pressurized. A leak at a sealing surface can cause a hazardous spray of water. Shut off the motor and verify the HP water pressure is relieved down the drain before servicing any high-pressure plumbing.
- Plumbing supports and guides must be used for all HP tubing exiting the pump. Failure to do so can introduce excessive bending stress and fatigue through vibration causing premature failure of the plumbing, and heighten risk of personal injury due to an unexpected rupture.
- Always use two wrenches when tightening or loosening HP connections: one for the gland nut and one for the fitting. This will prevent excessive bending stress and premature failure of the plumbing.
- Always use high-pressure piping rated for the type of system you are operating. This pump is capable of outputting 60,000 psi of water.

## Hydraulic System Safety



**WARNING**

**Pressurized fluid streams can penetrate skin, causing severe personal injury or death. If any fluid is ejected against the skin, seek immediate surgical attention.**

- Make sure all connections are properly tightened after performing service or maintenance.
- Keep hands and body away from pinholes and nozzles, which eject fluids under high pressure.
- Never check for hydraulic leaks with your hand: use a piece of cardboard or other material.
- Do not expose skin to a pressurized leak.
- Wear appropriate protective equipment including heavy gloves and safety glasses.
- Do not attempt to tighten or loosen any mechanical connection unless the machine is powered off and all system pressure has been relieved.

## Motor/Pump Assembly Safety



**WARNING**

**Beware of moving equipment. Keep clothing and hands away from equipment that is operating. Always verify covers and shields are in place before starting equipment.**

## 2.4 Emergency Medical Treatment

Waterjet equipment can cause severe injury and infection. Anytime a person comes in contact with a high pressure stream of fluid, it must be reported immediately and treated. It may look as though nothing happened, but a serious infection and possible amputation may result if immediate surgical attention is not received.

Always seek immediate surgical attention if you come in contact with any high pressure stream of fluid. Failure to do so can result in severe infection.

The injury should be treated as an acute surgical emergency and be evaluated by a qualified surgeon. Circulation may be compromised therefore **DO NOT** apply heat. Keep effected person awake and elevate injured part.

Inform the medical personnel that the victim has been working with a high-pressure mixture of water and abrasives at up to 60,000 psi and a nozzle velocity of up to 2,000 feet per second. Waterjet injuries have been known to cause infections with micro-Europhilic organisms such as gram-negative pathogens like those found in sewage.

## Emergency medical information

Anyone who receives **equipment related** injuries while operating high-pressure water equipment should be given immediate hospital attention. It is vital that waterjet operators carry a waterproof emergency medical tag or card that describes their work and the nature of injuries inherent in using waterjet cutting devices.

This card provides general purpose information to aid in relaying information to medical or emergency personnel.

<p style="text-align: center;"><b>MEDICAL ALERT</b></p> <p><b>This card is to be carried by personnel working with high-pressure waterjet equipment. Obtain medical treatment immediately for ANY high-pressure waterjet injuries.</b></p> <p><b>Hypertherm<sup>®</sup></b> Hypertherm Inc. 309 5th Ave NW New Brighton, MN 55112 +1 651-294-8600</p>
<p style="text-align: center;"></p> <p>This person has been working with water jetting at pressures to <b>60,000- psi (4,137bar)</b> with a jet velocity of <b>2000fps (610 mps)</b>. This should be taken into account during diagnosis. Unusual infections with microaerophilic organisms occurring at lower temperatures have been reported. These may be gram-negative pathogens, such as those found in sewage. Bacterial swabs and blood cultures may therefore be helpful. A <b>local poison control center</b> should be contacted for additional treatment information.</p>

## 3 Installation

---

### 3.1 Installation Overview

#### Buyer Obligations

The buyer of a HyPrecision 100D/150D waterjet pump is responsible to cooperate with Hypertherm and Hypertherm OEM personnel to facilitate installation of the machine.

- The pump should be uncrated and placed as close as possible to the position where it will be used.
- All utilities must be provided prior to installation as outlined in the **Specifications** section of this manual.
- The buyer should install high-pressure tubing unless other arrangements have been made in the sales agreement.
- Water treatment equipment should be in place prior to the installation of the pump. Water must meet the minimum requirements as outlined in the **Specifications** section of this manual.
- All connections to the pump are the responsibility of the buyer. It is the buyer's responsibility to research and comply with all local codes including wastewater disposal.

Hypertherm may or may not supply the pump without any hydraulic oil in the tank. It may be the buyer's responsibility to fill the tank with the appropriate oil per instructions in the **Hydraulic** section of this manual.

#### Seller Obligations

- If Hypertherm, Inc. is the installing party, some or all of the following tasks will be the responsibility of the Hypertherm technician at installation as defined in the sales agreement.
- Make sure the buyer has been informed of all buyer obligations and make sure the site has been properly prepared prior to installation.
- Make sure all utility connections have been properly provided as outlined in the **Specifications** section of this manual.
- Follow all first time startup and setup instructions as provided in the **Operations** section of this manual.
- Train maintenance personnel on proper service and repair procedures.
- Follow standard system acceptance tests.

### 3.2 Utility Requirements

#### Site Preparation



**WARNING**

**Certain locations may be hazardous if the atmosphere contains gas, vapors, or dust in explosive quantities. Refer to the National Electric Code (NEC), IEC, OSHA requirements, and local codes for detailed information about environmental criteria.**

The facility must have adequate air, water, sewer drain, and electrical service per the **Specifications** section prior to installation of the equipment.

Floor material should be concrete capable of supporting the weight of the machine, and thick enough to provide resistance to vibration.

## Water Requirements



**IMPORTANT**

Local codes may require that a back-flow prevention valve be supplied to separate the pump from the building potable water. Consult local codes for the required type and necessity of a valve.

## Cutting Water

The water supplied to the intensifier is a crucial factor in precision waterjet cutting because of its direct effect on the service life of equipment components. The pump's built-in filtration is sufficient for removal of suspended solids. Total Dissolved Solids (TDS) in the inlet water will have an adverse effect on check valves, seals, orifices, and other consumables. Most systems require that the water be softened at a minimum before it enters the pump.

Before installing the system have a water quality analysis performed by a local company that can provide water-conditioning equipment. See the **Inlet Cutting Water Requirements** section under **Specifications** for specific conditioning requirements.

## Cooling Water (if supplied with a Water/Oil Heat Exchanger)

The heat exchanger uses regular tap water for cooling the hydraulic fluid. Hydraulic fluid temperature must be maintained below 130°F. The **hydraulic cooling water** section of the **Specifications** area of this manual details the cooling water flow and temperature requirements.

In most cases public-utility water is acceptable. In situations where the water contains heavy mineral deposits, the cooling fins in the heat exchanger may become clogged with buildup. In these circumstances pre-filtration and/or softening may be necessary. Depending on plant setup, ambient temperature can also be a factor in cooling. Where the equipment is confined to a small high-temperature space, additional cooling may be required.

## Sewer Requirements

The pump has two outlet lines. The WASTE WATER OUT line carries any rejected cut water from the bleed-down valve. The COOLING OUT line carries the water exiting the heat exchanger in water cooling units. **DO NOT** couple lines.

Both outlets require independent lines to the sewer drain to prevent exiting cooling water from backing up into the system. The wastewater outlet plumbing must be lower than the outlet connection on the pump. This will prevent potentially dirty water from backing into the bleed down valve causing closure problems.

## Electrical Requirements



When connecting power to the pump it is the buyer's responsibility to investigate and comply with all local codes. The power requirements are listed on the serial plate on the back of the pump as well as on the inside of the electrical enclosure door.

### Three phase power connection

Each of the three phases of input power are connected to the three (3) terminals at the top of the motor switch (right). Additionally a ground leg must be attached to the grounding lug inside the electrical cabinet.

Pumps equipped for certain foreign power may have slightly different connection requirements. Always refer to the electrical schematic for the machine to verify proper connection.

Schematics are supplied in the **Drawings and Parts Lists** section of the manual and an additional copy is included inside the electrical cabinet.



## Location Requirements

- The pump must be placed in a location, which allows access to all sides for service.
- The pump should have a minimum 36 in. clearance surrounding the machine, free of all obstacles, to allow room for service. See the **Pump Requirements** section under **Specifications**.
- The pump should not be placed in any environment where the temperature is below freezing. If freezing temperatures are expected before operating again, drain all water lines and filter housings after work is completed for the day.



If a water line, fitting, or valve may be frozen, **DO NOT** operate the machine. The system must be thawed until water flows freely through the entire water circuit.

## Recommended Tools

Most maintenance of the pump can be accomplished using standard tools. Refer to the recommended tools list in the **Drawings and Parts Lists** section. Contact Hypertherm to purchase replacement specialty tools for intensifier and bleed-down valve servicing.





## 4 Operation

---

### 4.1 Operation Overview

This section outlines the operation of the Front Control Panel, as well as startup procedures, and normal operation. The HyPrecision 100D/150D pumps are controlled from the front control panel.

The main disconnect on the electrical enclosure must be turned on in order for the pump to function.

### 4.2 Front Control Panel

The HyPrecision 100D/150D pumps are controlled via an Operator Control Station (OCS) attached to the outside of the Electrical enclosure. The OCS monitors all fault conditions and controls the intensification process. Certain pump models referred to as OEM may not have a control panel. In this case, refer to the manual for the equipment that is controlling the pump.

The OCS is equipped with digital inputs and outputs for monitoring all pump and environmental conditions as well as controlling the functions of the pump.

Other features include intensifier enable/disable, intensifier-overstroke threshold setup, and alarm logging.

Log files are stored on a removable MicroSD card. When troubleshooting is necessary, the card can be removed from the pump and the information transferred via a USB reader to Hypertherm technicians. Program updates can also be installed by simply copying a new program onto the card and replacing it in the pump.

No service is necessary on the OCS. All inputs and outputs run to terminal blocks, which should be used for wiring the remote options. Refer to the supplemental control manual, for additional details about control operation and features.

### Standard Control Panel

Base model pumps have the standard control panel. The standard control panel has an OCS panel, hydraulic gauge, cut pressure adjustment knob, and pierce pressure adjustment knob. In addition, there are water gauges indicating the pre and post filter water pressure.

The following image shows the standard control panel (all HyPrecision 100D/150D models).

**CONTROLS ON:** Enables the pump controls.

**LOCAL/REMOTE KEYSWITCH:** Switches from local pump control to remote pump control. See **Remote Pump Operation** under the **Operation** section in this manual.

**EMERGENCY STOP:** Shuts off controls, motors, and intensifiers, and bleeds down the high-pressure water.

**REMOTE ACTIVE light:** Lit when pump is in remote pump control mode or remote pressure control mode.



Depending on the type of pump model(s) you have the layout of the gauge panel will vary.

The **PIERCE PRESSURE** and **CUT PRESSURE** adjustment knobs, located on the gauge panel, are manually operated.

Units with the optional analog pressure control will not have the **CUT PRESSURE** and **PIERCE PRESSURE** control knobs, which are replaced with a high precision electrical control valve.

**CUT PRESSURE knob** (if applicable): Adjusts Pressure Set Point 1 (Cut). See **Adjusting the Cut and Pierce Pressure** in the **Operation** section for more information.

**PIERCE PRESSURE knob** (if applicable): Adjusts Pressure Set Point 2 (Pierce). See **Adjusting the Cut and Pierce Pressure** in the **Operation** section for more information.

**HYDRAULIC PRESSURE gauge**: Displays the hydraulic pressure of the pump. Pumps with more than one hydraulic pump will have additional gauges. The hydraulic pressure gauge can be useful in determining the approximate cut pressure. To do so, use the following formula:

$$\text{Cut Pressure} = 19.25 \times \text{Hydraulic Pressure}$$

**PRE-FILTER WATER PRESSURE gauge**: Displays the water pressure before the filter bank. See the **Low-Pressure Water** section of this manual for more information.

Normal operating range: 40-110PSI

**POST-FILTER WATER PRESSURE gauge**: Displays the water pressure after the filter bank. See the **Low-Pressure Water** section of this manual for more information.

Normal operating range: 40-110PSI



## 4.3 Pump Startup

### Initial or Post-Maintenance Startup

The first time you start up your pump it is important that the Pre-Startup Inspection, Motor Direction Check, and First Time Startup procedures (below) be performed to prevent serious damage to the pump components. Make sure that all installation requirements have been met prior to performing any of the following checks. Follow all safety procedures as outlined in the **Safety** section of this manual.

It is common to identify leaks in the high-pressure water, low-pressure water, and possibly hydraulic circuits while performing these procedures. Always stop the procedure and correct the leaks before continuing.

#### Pre-Startup Inspection

1. Verify all safety circuits are connected and operational.
2. Check the sight gauge to make sure the hydraulic reservoir is full. Add oil as necessary to bring the oil to an acceptable level. Refer to **Hydraulic Oil** in the **Hydraulic** section in this manual for instructions on adding oil.
3. Verify all utilities are connected to the pump and turned on at the plant.
4. Check for loose hoses and fittings and make sure there are no leaks present.



#### Motor Direction Check



This procedure involves exposing a rotating shaft. Never place any object or any part of your body near the shaft while exposed. Only visual inspection should be used to prevent bodily injury. Be prepared to press the **EMERGENCY STOP** button.



The motor direction check should be performed anytime electrical maintenance has been performed on the electrical panel, motor wiring, or line wiring to the pump. Improper motor rotation can cause irreversible damage to the hydraulic pump and components.

1. Open or remove the front cover from the pump and locate the motor rotation arrow.
2. Remove the safety cover on the pump mount and visually inspect the coupling rotation.
3. To jog the motor, pull the **EMERGENCY STOP** button on the control panel, and then press the **CONTROLS ON** button.
4. Press  (**COOLING MODE**) and then press  (**PUMP OFF**) to jog the motor. Verify visually that the shaft is rotating the same way the motor rotation arrow indicates.

If the motor rotates in the wrong direction, swap two of the wires at the starter panel's **MAIN DISCONNECT**, not at the motor or starter contactors, and then recheck the rotation. After verifying motor rotation, replace the safety cover on the pump mount and the side covers. Also, see **Motors** in the **Electrical System** section for additional information.

## First Time Startup



### IMPORTANT

The following first time startup procedure should be followed after any service has been performed on the intensifier, high-pressure water, or low-pressure water assemblies.

1. Make sure the cut pressure and pierce pressure adjustment knobs are backed out all the way. If the pump has analog pressure control make sure the pressure setting is **10ksi** or less.



The pump may have been shipped with loose fittings, filters, and components depending on winterization requirements, where the pump is shipped to, and other environmental factors. Make sure that all of the water fittings and loose components are tightened before proceeding to the next step.

2. Prime the flow of the cutting water:
  - a. Disable the Intensifier.
  - b. Open the cutting head.
  - c. Turn the source water on.
  - d. Let sit for 2-3 minutes.
  - e. Depress the red button on the top of each of the filter housings to bleed air from the canisters.
  - f. Close the cutting head.
3. Start the pump by pressing the  (**PUMP ON**) button on the touchscreen display. Make sure that the boost pressure meets the inlet water requirements as outlined in the **Specifications** section of this manual.
4. Check again for any leaks and loose fittings. Take any corrective action and then proceed to the next step.
5. Flush the pump and high-pressure lines using the following procedure.

## Flushing HP Water Lines

After installation of a new pump and high-pressure lines, it is common for small pieces of metal and debris to be present in the high-pressure lines.



### IMPORTANT

**NEVER perform the initial startup with a diamond orifice in place. The likelihood of damaging the orifice during the initial startup is very high!**



**It is important to flush the system to prevent damage to orifices, on/off valve parts, and other parts of the HP system.**

The following procedure describes one method to “flush out” the HP lines. If you purchased your Hypertherm pump through an OEM, they may have their own procedure that they recommend. During this procedure, damage may occur to the on/off valve sealing parts and orifices. Make sure to have spare kits and orifices available before starting the procedure.

This flushing procedure should be followed after any replacement or service to the high-pressure lines and fittings have been performed on the pump.

1. Make sure the pierce pressure control knob is backed out all the way, and the pump pressure is set to **10ksi** or less. See **Adjusting the Pump Pressure** in the **Operation** section for more information.
2. Remove the cutting head and orifice leaving just the on/off valve body and adapter.
3. Set the pump pressure to **20ksi** (approximately 1000 psi hydraulic) using the pump compensator. See **Adjusting the Pump Pressure** in the **Operation** section for more information.
4. If possible, use your CNC control to make a program that will turn on and off the valve in one-second increments and run the program in a loop for 15 minutes. This will shock the HP tubing and free any debris present in the lines.



**Any debris that breaks can cause damage to your on/off valve needle and seat. If this happens, try to complete this procedure by removing all debris from the components rather than replacing the parts right away.**

5. Replace the sapphire orifice in the cutting head with one that is appropriately sized for your pump.
6. Set the pump pressure to **40ksi** (approximately 2000 psi hydraulic) and repeat the program (above) for another 15 minutes.
7. Turn the pressure up to **60ksi** (3000 hydraulic) and repeat the program again for 15 minutes.
8. If necessary, replace the on/off valve needle, seat, and seals as well as any damaged orifices.

## Normal Startup Procedure

1. Verify all safety circuits are connected and operational.
2. Check the sight gauge to make sure the hydraulic reservoir is full. Add oil as necessary to bring the oil to an acceptable level. Refer to **Hydraulic Oil** in the **Hydraulic** section of this manual for instructions on adding oil.
3. Verify all utilities are connected to the pump and turned on at the plant.
4. Check for loose hoses and fittings and make sure there are no leaks present.
5. Press  (**PUMP ON**) and verify that the boost pump pressure is **50-115 psi**. The pump will start generating pressure at the Pressure Set Point 2 (Pierce) for **five seconds** before switching to Pressure Set Point 1 (Cut).

Refer to the **Pump Operation** section for instructions on setting the pressure set points.

## 4.4 Pump Operation

After startup inspections have been completed and the machine is running, no further direct action from the operator is required. Periodically check warning indicators and gauges and inspect everything visually to ensure developing problems are detected before the equipment is damaged.

### Normal Operation

During normal operation, the pump will continue to stroke to meet the cutting water demand. When the cutting nozzle is closed, the pump will operate on standby; hydraulic pressure remains at the set pressure and the intensifier is idle. It is normal to see an increase in the pressure of the output water. This is called the "Dead Head Rise." When the cutting nozzle is turned on the intensifier will begin to stroke again at a rate to meet the demand.

## Adjusting the Cut and Pierce Pressure

The cut pressure and pierce pressure can be adjusted using the knobs on the front of the pump. To adjust the cut and pierce settings for pumps equipped with Analog Pressure Control, refer to the following section. To adjust the cut and pierce pressure, the pump must be running.

To adjust cut pressure, the **CUT PRESSURE** icon  must be active (light blue). Touch the icon to activate the cut pressure. To increase cut pressure, turn the cut pressure knob clockwise. To decrease cut pressure, turn the knob counterclockwise.

To adjust the pierce pressure, the **PIERCE PRESSURE** icon  must be active (light blue). Touch the icon to activate the pierce pressure. To increase pierce pressure, turn the pierce pressure knob clockwise. To decrease pierce pressure, turn the knob counterclockwise.



**If the set point of the cut pressure is lower than the set point of the pierce pressure in the PIERCE mode, the pump will operate at the lower cut pressure.**

**Tip:** To extend the life of your high-pressure seals and other high pressure components, turn the cut pressure all the way down by backing out the cut pressure knob **before** shutting off the pump. When restarting the pump, slowly ramp up the cut pressure knob until you are at the desired set point.



## Analog Pressure Control

Pumps that are equipped with Analog Pressure Control operate similar to the standard pumps. The set point values on the analog pressure control adjust with the OCS rather than the control knobs.

To adjust cut pressure, the **CUT PRESSURE** icon  must be active (light blue).

Touch the icon to activate the cut pressure. To increase cut pressure, push  on the display.

To decrease cut pressure, push  on the display.

To adjust the pierce pressure, the **PIERCE PRESSURE** icon  must be active (light blue). Touch the icon to activate the pierce pressure. To increase pierce pressure, push  on the display. To decrease pierce pressure, push  on the display.

## Remote Pump Operation

Hypertherm HyPrecision 100D/150D Intensifier Pumps come standard with built-in functionality for remote operation. Information on wiring connections is provided in **Electrical Control Panel** in the **Electrical System** section of the manual.

**Remote Pump Control (RPC)** deactivates the **CONTROLS ON**, **PUMP ON**, and **COOLING ON** at the front panel of the pump. These inputs are then solely controlled from a remote source.

**PUMP OFF** and **EMERGENCY STOP** are active at both the front control panel and the remote source. RPC is activated by turning the key switch to the **REMOTE** setting.

## Normal Shutdown Procedure



**CAUTION**

**Never leave waterjet cutting equipment turned on and unattended.**  
**After the equipment is shut down, always make sure the high-pressure water is relieved by turning on the cutting head.**

1. Turn the cutting equipment **OFF**.
2. Press the  (PUMP OFF) on the pump control screen.
3. Pull or rotate the main disconnect handle on the panel door to the **OFF** position (down).
4. Turn **OFF** the plant cutting and cooling water connections to the pump.
5. Verify the high-pressure water gauge reads zero (if present) or turn on the cutting head to release any remaining water pressure.

## Emergency Shutdown Procedure

The pump has an **EMERGENCY STOP** palm button located on the front control panel. In the event of an emergency, press the **EMERGENCY STOP** palm button. This will immediately remove any electrical power from the motor and controls. The bleed-down valve will open and the high-pressure water should be relieved down the drain.

If the pump is configured to run remotely and has a motion system, the emergency circuits from the robot or cutting table may be in series with the local emergency stop circuit.

In the event that the pump has been shut down from a **remote emergency stop** circuit, the operator will need to remove or reset that condition first. The pump can be re-started following the normal startup procedure listed earlier in this section. A normally closed dry contact is provided at the back of the **EMERGENCY STOP** button for remote equipment shutdown.





## 5 Electrical System

---

### 5.1 Electrical System Overview

The electrical enclosure contains the main disconnect, the motor starters, and the control components. All internal control power is derived from the three phase input power. The **Electrical** section of this manual describes the following:

- Electrical Control Panel
- Motors and Motor Starter Circuits
- Fault Detection

### 5.2 Electrical Control Panel

#### Operator Control Station

The operator controls the intensifier pump through the Operator Control Station (OCS) on the front of the electrical enclosure see **Front Control Panel** in the **Operation** section. Refer to the supplemental control manual for additional details about control operation and features.

#### Disconnects and Fuses

The electrical cabinet is powered by 3-phase AC incoming power. All motors are run using the same 3-phase power input. Some control enclosures may have a transformer for 110VAC as required.

All field components (i.e. solenoid valves, sensors, etc.) use **24VDC** power. Fusing is provided for the PLC outputs, 24VDC power supply, and the transformer (if present). Refer to the electrical schematic for fuse sizes and locations. Some spare fuses are included with the controller. All fuses can be purchased from Hypertherm or an electrical supply store.

#### Remote Operation Wiring

Hypertherm HyPrecision 100D/150D pumps come standard with built in functionality for **REMOTE** operation. The pump includes two options for external control that integrators can use: External Pressure Control and Remote Pump Control.

Remote Pump Control (RPC) deactivates the **CONTROLS ON**, **PUMP ON**, and **COOLING ON** at the front panel of the pump. These inputs are then solely controlled from a remote source. **PUMP OFF** and **EMERGENCY STOP** are active at both the front control panel and the remote source. RPC is activated by turning the key switch to the remote setting. The wire connections and terminal block information are included in the schematic for this pump.

## RPC Operational Connections

Description	Wire No	Voltage	Type Contact
Remote Controls On <sup>1</sup>	6027, 5024A	24VDC	Momentary, Normally Open (NO)
Remote E-Stop	5024A, 5024B	24VDC	Normally Closed (NC)
Remote Pump On	6028, 24VDC	24VDC	PLC Input, Momentary, NO
Remote Pump Off	6029, 24VDC	24VDC	PLC Input, Momentary, NC

## RPC Status Connections

Description	Wire No	Voltage	Type Contact
Remote Controls On <sup>1</sup>	6027, 5024A	24VDC	Momentary, Normally Open (NO)
Remote E-Stop	5024A, 5024B	24VDC	Normally Closed (NC)
Remote Pump On	6028, 24VDC	24VDC	PLC Input, Momentary, NO
Remote Pump Off	6029, 24VDC	24VDC	PLC Input, Momentary, NC

## RPC Emergency Stop Connections

Description	Wire No	Voltage	Type Contact
Remote Cooling Mode	6030, 24VDC	24VDC	PLC Input, Momentary or Maintained, NO
Discrete Pressure Input	6022, 6022A	24VDC	PLC Input, Maintained, NO
Controls On Indicator	5024C, 24COM	24VDC	PLC Output
Remote Mode Active Indicator	6027, 24COM	24VDC	PLC Output
Remote Pump Fault Indicator	7004, 24COM	24VDC	PLC Output
Remote Pump Run Indicator	6047, 24COM	24VDC	PLC Output

---

<sup>1</sup> Optionally you can require the operator to turn the key switch to **LOCAL** mode, press the **CONTROLS ON** button, then turn the key switch back to **REMOTE**. When doing it this way any time a fault shutdown or E-Stop occurs you will need to turn the controls on this way at the pump.

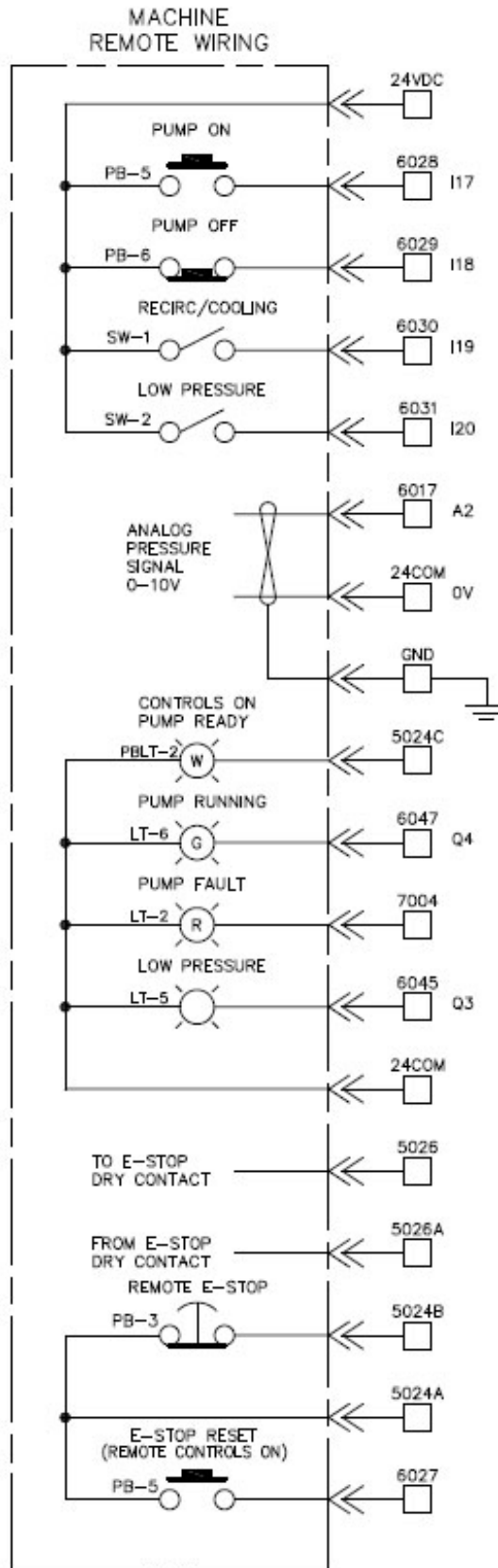

Description of Remote Connections	
<b>Remote Controls On</b>	This activates the controls by turning on the main control relay. The controls must be on before any other commands are accepted. See note 1 under <b>Required RPC Connections</b> for information on turning on the controls when this input is absent.
<b>Remote E-Stop</b>	The remote E-stop terminals provided are in series with the pump E-stop circuit. Normally these would be wired to dry contacts on an E-stop at the remote control source. Connection to this E-stop is the responsibility of the integrator. One set of dry contacts are also provided on the back of the Hypertherm E-stop button. These contacts open when the Hypertherm E-stop button is activated.
<b>Remote Pump On</b>	The remote pump on input performs a sequential startup of the entire pump. This turns on the inlet water, and main motor. After the motor is at speed the intensifier will start stroking at low pressure first for a preset time and then switch to high pressure. If the pump is in cooling mode, pressing the pump on will start the intensifier stroking.
<b>Remote Pump Off</b>	This input turns the intensifier, motor, inlet water, and cooling fan (if present) off. After the pump is shut down, you must choose cooling mode or pump on in order to start the pump. For stand-by condition in between programs, it is recommended to leave the pump running.
<b>Remote Cooling Mode</b>	Cooling mode turns the motor and inlet cooling water or cooling fan logic on. Cooling mode also turns off the intensifier if it is running.
Indicators	
<b>Remote Controls On</b>	Status indicator of controls circuit. The controls are on when 24VDC is present.
<b>Remote Mode Active</b>	Status indicator of remote mode. The pump is in external pressure control or remote pump control mode when 24VDC is present.
<b>Remote Pump Fault</b>	Status indicator for fault monitoring. Any fault condition that displays a message on the screen or flashes a yellow or red light will cause this output to turn on. 24VDC indicates a fault is present.
<b>Remote Pump Run</b>	Status indicator for pump motor. The remote pump indicator will turn on any time the motor is running.

## 5.3 Motors



**WARNING**

Always make certain the electrical current is shut off and lockout/tag-out procedures have been followed before starting any service or maintenance procedures.



**IMPORTANT**

In the event of any kind of overload fault, always determine what caused the fault before starting up the motor again.

The main motor is the backbone of the HyPrecision 100D/150D Intensifier Pump. The motor transfers rotation through a jaw type coupling to the main pump, which is through-shafted to the gear pump.

### Motor Starter Circuits and Thermal Overloads

Hypertherm pumps are equipped with different starter circuits depending on the size of pump and the inrush current requirements. All motor starter circuits have thermal overload protection to keep the motor from overheating and causing irreparable damage. Main motor starter circuits utilize soft starters.

#### Softstarter with Bypass Contactor

HyPrecision 100D/150D are equipped with a Softstarter. This is considered a reduced voltage class of starter. When the motor is turned on through the operator interface or from a remote signal, the Softstarter ramps the motor up to speed over a factory set amount of time. After the starter reaches the Top of Ramp (TOR) it switches the load to a bypass contactor.

The Softstarter monitors a large variety of conditions including calculated or actual motor temperature and will trigger a motor fault shutdown in the event conditions occur that exceed the factory-preset values. The fault may be cleared from the operator interface by pressing RESET on the alarm screen. If the condition that caused the fault remains present, you will not be able to reset until the condition is corrected.



For example, if the motor shuts down due to a thermal overload condition you will not be able to reset the fault until the motor cools below the preset level. The Softstarter is locked and it will require a password to change any factory set values. If you need Softstarter assistance, please contact an authorized Hypertherm Service Center.

## Boost Pump and Fan Motor Starters

The boost motor starter uses an integrated starter and thermal overload device. The optional fan motor starter is similar to the boost motor starter. The overload setting has been factory set and should not be adjusted unless instructed to do so by an authorized Hypertherm service representative. To reset the **OL-BOOST** or **OL-FAN** turn the dial to **RESET** and then back to **AUTO**. If your shop has high water pressure it is possible that the boost pump would elevate the water pressure beyond the 125psi maximum. In this case, you should turn the dial switch to off and run without the boost pump. In addition, you will need to disable the Boost Fault Monitoring setting in the PLC. Contact Hypertherm or refer to the supplemental control manual for information on changing this setting.



## Motor Service

### Boost Motor Replacement and Direction Check

In rare cases, the boost motor may need to be replaced. If the boost motor is in need of replacement always make sure to wire the new motor following the proper wiring diagram for the 3 phase voltage of your pump. After replacing the motor, it is necessary to perform a rotational direction check. Take the following steps to ensure that the motor and boost pump are not damaged from improper rotation.

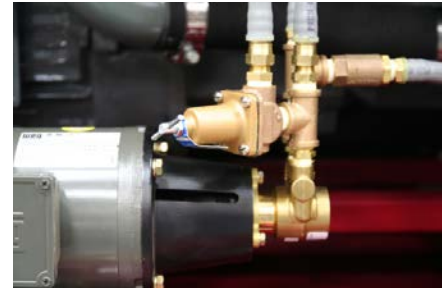

1. Remove the front and rear cover from the pump.



**Make sure that you can see the boost motor coupling through the pump mount. It may be necessary to have two people for this procedure.**

2. To **jog** the motor, pull the **EMERGENCY STOP** button on the control panel, and then press the **CONTROLS ON** button.
3. Press  (**PUMP ON**) and then quickly press  (**PUMP OFF**) to jog the motor.
4. Verify visually that the shaft is rotating the same way the pump rotation arrow indicates.

If the motor rotates in the wrong direction, swap the pair of wires at the bottom of the boost motor starter **MS-BOOST**. Perform the previous steps again to make sure the rotation has reversed.

After verifying motor rotation, replace any covers that were removed.

### Main Motor Lubrication

The main motor in the Hypertherm pump needs to be greased periodically. Use a good quality, moisture-resistant, polyurea-based grease such as Chevron SRI #2.



**Do not use lithium-based grease: mixing the OEM grease with lithium grease may result in loss of lubrication, shorter motor bearing life, and shorter motor life.**

**Do not over-grease the bearings. Refer to the Maintenance section of the manual for recommended intervals to grease the motor.**

## 5.4 System Fault Detection

HyPrecision 100D/150D pumps have a series of fault conditions that are constantly monitored by the PLC. External stack lights or panel lights will blink to alert the operator that a fault has occurred.

If a fault condition is sensed by the control system, an alarm image will be displayed on the LCD screen. Each fault condition is classified into one of three categories of severity: **WARNING**, **SHUTDOWN I**, and **SHUTDOWN II**. The following is a list of conditions broken down by category. For information on troubleshooting these conditions, please refer to the Maintenance and **Troubleshooting** section of this manual.

- **Warning** conditions: the **yellow** light blinking and an image will be displayed on the LCD screen.
- **Shutdown I** conditions: the **red** light blinking and intensifier shutdown but the motor is still running. An image will be displayed on the LCD screen.
- **Shutdown II** conditions: the **red** light blinking and the motor and intensifier shutdown. An image will be displayed on the LCD screen

### Warning Messages

Warning messages are the least severe of the categories. The purpose of the warning is to alert the operator of conditions that, if ignored, can result in a shutdown condition. The following conditions can cause a warning to occur.

- HYDRAULIC OIL TEMP > 130°F (55°C)
- TOO MANY MOTOR STARTS PER HOUR

#### *Hydraulic Oil Temp >130°F (55°C)*

The probe in the hydraulic oil tank has two temperature switches to monitor conditions. One switch opens at **130°F** (55°C) and the other at **150°F** (65°C). If the lower temperature is exceeded the yellow light will begin to flash, warning the operator of a potential cooling water problem.

In systems that are cooled with water, the most likely cause of this condition is the cooling water is not turned on or the inlet cooling water temperature is too high. The water-modulating valve may also be out of adjustment. Review the **Low-Pressure Water** section of this manual to troubleshoot the cooling water. After correcting the problem, press **RESET** on the control panel alarm screen to turn off the Warning light and reset the fault.

Systems equipped with air/oil coolers can trip the overload on the fan starter. If necessary, reset the starter and set it to the **ON** position. Fan cooled systems have a third temperature switch that is used to determine when the oil has reached a temperature high enough to require cooling. A loose wire or failed switch could also result in an over-temperature condition.

#### *Too Many Motor Starts per Hour*

The motor can be damaged if it is started too frequently. The threshold for this warning is set to six times in 15 minutes. If this number is exceeded, the yellow light will blink and the message will be displayed on the LCD screen. Reset the alarm by pressing **RESET** on the control panel alarm screen. Wait 15 minutes before starting the motor to allow time for the windings to cool.



## Shutdown I Messages

Shutdown I fault conditions are severe enough to require the intensifier to shut down but will allow the motor to keep running. The red light will be flashing and one of the following images will be displayed on the LCD screen.

- INLET WATER PRESSURE BELOW 40 PSI (2.8 BAR)
- HYDRAULIC OIL TEMP > 150°F (65°C)
- INTENSIFIER OVERSTROKE

### *Inlet Water Pressure Below 40 psi (2.8 bar)*

The most likely cause is a failure of the water supply to the pump. A **pressure switch** senses the water pressure after the filters. If the water pressure falls below the set point, the monitoring circuit will **open** and this fault will occur. Make sure that the plant supply water is turned on. Verify that any manual or electrical inlet valves are open and functioning properly.

Some pumps are equipped with an inlet-water solenoid valve. If the cutting water solenoid does not open when the motor is turned on, a fuse could be blown. Refer to the schematic to determine which fuse is protecting the PLC output for the inlet water solenoid. The fuses have holders that light up when the fuse is blown to make it easy to identify. Determine the cause of the blown fuse before replacing it. If the fuse was blown because of a damaged solenoid valve, replace the valve. Clogged water filters can also cause low inlet water pressure.

Read the **Low-Pressure Water** section of the manual to identify other possible causes. Once the problem is corrected, press the **RESET** button on the alarm screen and resume normal operation of the pump.

### *Hydraulic Oil Temp > 150°F (65°C)*

If the temperature of the oil in the tank exceeds 150°F (65°C), the red light will begin to flash and the intensifier will shut down warning the operator of a potential cooling water problem. Refer to the previous paragraph for information about potential causes. After correcting the problem, press the  (F1) button on the OCS to turn off the warning light and reset the alarm. If the alarm persists longer than a preset amount of time, the pump will shutdown completely.

### *Intensifier Overstroke*

The Intensifier Overstroke fault is caused when the hydraulic piston travels one or both ways too quickly. If the intensifier strokes too many times in one direction, other than during startup and when switching from low to high pressure, and each stroke is less than the set threshold, the overstroke fault will be triggered. The message will have an indicator to the direction the piston is traveling when the fault occurs. The arrows can be very helpful in determining which side may be the cause of the problem. Refer to the **Intensifier Cycling** subsection of the **High-Pressure Water** section of the manual. After identifying the cause and taking corrective action, press the **RESET** button on the alarm screen and resume normal operation of the pump.



## Shutdown II Messages

Shutdown II messages indicate a severe fault that requires the motor and intensifier to shut down. The red light will flash and one of the following fault images appears on the LCD screen.

- HYDRAULIC OIL LEVEL LOW
- MOTOR FAULT

### *Low Hydraulic Oil Level*

The probe in the hydraulic oil tank has a float switch. When the oil level is too low, the float drops and the low hydraulic oil level alarm is triggered. The most likely cause of this alarm is loss of oil through routine maintenance. If this is the case, add oil to the appropriate level, reset the fault and resume normal operation. If the oil loss is not due to routine maintenance, find out where the oil has gone. If the oil is in the catch pan at the bottom of the pump, it should be fairly easy to find the leak. If it is not in the bottom of the catch pan, it could be leaking undetected through the heat exchanger. Repair all leaks and fill the tank with the specified hydraulic oil to the top of the sight gauge. Press **RESET** to clear the fault and resume normal operation.

### *Motor Fault*

The main motor starter (MS-MAIN) in the pump electrical enclosure has thermal overload protection to prevent motor damage from excessive heat. Refer to **Motor Starter Circuits and Thermal Overloads** in the **Electrical System** section for important information regarding motor service and safety.

There are several reasons why this fault may be occurring. One common reason for a motor fault message is a blown fuse corresponding to that output on the PLC. A fuse may be blown for several reasons including a failure of a device on one of the other outputs using the same fuse. In the event that a device on the output other than the motor causes the motor fault, make sure that the problem device is repaired or replaced before resetting the fault and starting the pump again.

Another possible cause is excessive water demand. If an orifice has broken or plumbing is leaking water, demand may be high enough to cause the motor to overload. Hypertherm pumps are setup with protection from this scenario. Reduce water demand and reset thermal overload.

A less likely cause of this fault may be a bad hydraulic pump, faulty motor, or an incorrect thermal overload setting. These conditions are very rare. Please contact an authorized Hypertherm service representative if any of these conditions occur.



## 6 Low-pressure Water System

---

### 6.1 Low-pressure Water Overview

This section describes the components and operation of the **Low-Pressure Water** assembly. Some references to components and assemblies may not be applicable to your pump model. For example, systems equipped with an air/oil cooler will not have a water/oil heat exchanger. Refer to the **Drawings and Parts Lists** section of the manual to determine which components you have.

- Inlet Cutting Water Supply
- Cooling Water Loop (Not all Models)
- Waste Water Discharge

The hookups for these connections are located on the utility panel of the pump usually located at the back. Details of incoming and outgoing utility connections are included in the installation drawings for your pump model and in the **Drawings and Parts Lists** section of this manual.

### 6.2 Inlet Cutting Water Supply

The inlet cutting water supply includes all the plumbing components from the pump inlet connection to the inlet to the intensifier. It includes the following:

- Boost Pump Assembly
- Inlet Cutting Water Filtration
- Low-Pressure Water Switch

The low pressure cutting water circuit can be used with inlet water qualities that are provided by water softening or reverse osmosis. De-ionized water is not recommended unless your system was purchased with all stainless steel water fittings. Most installations with normal city water pressure do not require an adjustment of the bypass relief valve. See the **Inlet Cutting Water Requirements** in the **Specifications** section of the manual for further information.

### Inlet Water Valves and Connections

All Hypertherm pumps have incoming water connections on a utility bulkhead. Electronic solenoid valves and manual valves at the bulkhead fittings control incoming water supply. The incoming water connection details are outlined in the **Specifications** section as well as on the installation drawings for your specific pump.

### Boost Pump Assembly

The boost pump takes the relatively low-pressure inlet water and elevates it to a higher pressure to provide adequate intensifier water supply to meet the higher flow rates of larger pumps.

The boost pump assembly consists of the pump, a bypass relief valve, and a check valve. It operates by taking the inlet supply water and adding pressure based on the setting of the bypass relief valve.

The pump has been set up to operate with inlet water pressure of **40 to 70 psi**. If you are providing incoming cutting water from a reverse osmosis system, please contact an authorized Hypertherm service representative to make sure that the boost settings are correct. The bypass relief valve has been factory set to create a boost pressure of **60 psi**. For example, an inlet pressure to the pump of **50 psi** will result in a total pressure of **110 psi**.

The inlet water components of the pump are rated to a maximum pressure of **125 psi**. High inlet pressure may result in the boost pump creating excessive pressure and damaging components. If either of the panel gauges reads over **125 psi**, turn off the boost pump as explained below.

A pressure relief valve is also included in-line with the filter assembly (see picture) to avoid inlet pressures above **125 psi**. The pressure relief valve is factory set to **120 psi** and should not need adjustment. If either panel gauges reads over **125 psi**, contact an Hypertherm service representative regarding resetting and/or servicing the pressure relief valve.



The boost pump is protected from overheating by the PLC control. When there is no demand for cutting water the boost pump will automatically shut off and not turn on until demand has returned. If the water pressure falls below the pressure set point of the low-pressure switch the boost pump will resume operation.

## Boost Pump Pressure Adjustment

This adjustment must be made with the **pump turned off**. It is factory set to provide correct inlet cutting water pressure as supplied by municipal water or well pumps. In cases where the pump is supplied by a tank, such as on a reverse osmosis system, it is necessary to increase the boost pressure. The boost pump pressure-relief valve is adjusted by **loosening** the jam nut and **turning** the T-handled adjustment screw (image at right). Turn clockwise to increase the pressure or counterclockwise to decrease pressure.

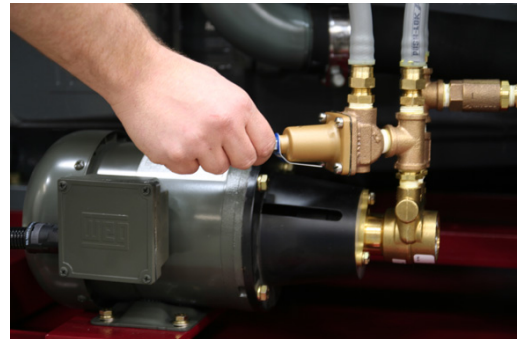

## High Inlet Water Pressure

Inlet water pressure that exceeds 70 psi requires that the boost pump be turned off. Open the electrical cabinet and turn the switch located on the boost pump motor contactor to **OFF (0)**.



**The electrical cabinet contains high voltage. Extreme care should be used when working in this area. If you are unfamiliar with this area, a qualified electrician should be used.**



After turning off the boost pump inside the cabinet, you must also turn off Boost Fault monitoring in the PLC. This can be done by entering the configuration screen then pressing View Pump Config and pressing More. Press the button on the screen to change the setting to OFF.

## Inlet Cutting Water Filtration

All Hypertherm HyPrecision 100D/150D pumps come with two or three water filters that remove contaminants from the cutting water. Two water gauges are located on the front panel of the pump or on either side of the filters to show the pressure before and after the filters. These gauges are used to determine the pressure drop across the filters. Swivel connections are provided at the HP end caps for easy removal for service. A manual ball valve (4) is provided to discharge the accumulator prior to performing maintenance. **If the filters start to clog to the point that the post-filter water pressure is below 40 psi and/or the pressure drop across the filters is greater than 15 psi, you must replace the filters.**

In order to maintain necessary water pressure for the pump and to keep the water clean for proper operation, it is necessary to replace the water filters periodically. The filters should be replaced as needed.

## Water Filter Service

Replace filter elements when there is a 10-psi pressure differential between the two gauges located on the pump control panel.

### Replacement Parts:

- 10 Micron Filter (1) (Models with Three Filter Elements)- AS part # 11107
- 1 Micron Filter (2) (All Models) - AS part #11106
- 0.45 Micron Filter (3) (All Models) – AS part # 11105



### Recommended Tools:

Strap Wrench or Filter Wrench (for turning filter housing)

## Water Filter Element Replacement Procedure

Replacing the filter components

1. Turn the pump off.
2. Open the discharge ball valve (4) to relieve trapped pressure.
3. Unscrew the filter housing from head. Remove element.
4. Install new elements in the housing. Screw the housing into head.
5. Close the discharge ball valve (4).
6. Turn the pump motor on to turn on the inlet valve and boost pump.
7. Press the bleed valve located on the top of the filter housing to remove trapped air.
8. Start the waterjet pump. Verify satisfactory pressure readings.

## Low-Pressure Water Switch (Not all Models)

A pressure switch located after the filters senses low water pressure to the intensifier. A sustained pressure of below **40 psi** will result in pump shutdown. This protects the system from running without enough feed pressure to the intensifiers.

## 6.3 Cooling Water Loop (Not all Models)

The cooling loop consists of an inlet water valve to turn on the cooling water. The electronic solenoid valve (if applicable) will automatically turn on the cooling water any time the motor is running. Models without an electronic solenoid valve will have to be controlled manually using a ball valve. Models with water/oil coolers may also have a water-modulating valve to control the cooling water flow rate relative to the hydraulic oil temperature. A probe in the tank senses the oil temperature and adjusts the water flow to maintain a steady hydraulic oil temperature.

The modulating valve has been factory set to keep the oil temperature at approximately **115°F (45°C)**. Local air and water temperatures may require that the modulating valve be adjusted.

### Water Modulating Valve Adjustment

The oil temperature in the hydraulic tank should be maintained at approximately 115°F. High hydraulic oil temperatures can adversely affect oil life and high-pressure seal life.

#### Adjustment Procedure:

1. If the oil temperature is over **115°F**:
2. Turn the screw 1/4 turn clockwise to reduce oil temperature.
3. Wait 15 minutes and look at oil temperature.
4. Repeat procedure until oil temperature is **at or below** 115°F.

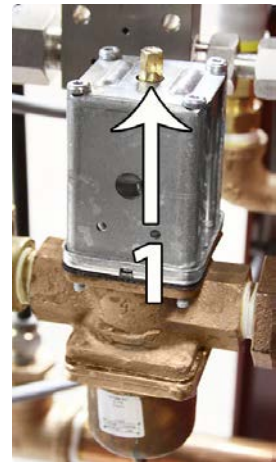

## 7 High-pressure Water System

---

### 7.1 High-pressure Water Overview

The high-pressure (HP) water system increases the relatively low-pressure water inlet up to **60,000 psi** (4,137 bar). Maximum flow rates and orifice diameters are provided in the **Specifications** section of this manual.

The High-Pressure Assembly consists of the following four (4) major components:

#### Intensifier

The Intensifier assembly contains three major subsections or cylinders. The center section contains the hydraulic cylinder and the two (2) outer sections contain the high-pressure ends. The Intensifier Assembly uses the pumps hydraulic power to reciprocate the center hydraulic piston with a plunger connected to each side of the piston. The two plungers reciprocate in the high-pressure cylinders to make the high-pressure water. Each side of the intensifier has one low pressure and one high-pressure check valve to bring in the inlet water and output high-pressure water.

#### Bleed-Down Valve

The Bleed-Down Valve Assembly discharges high-pressure water from the pump when the pump is turned off or when the hydraulic pressure is reduced.

#### Attenuator

The Attenuator Assembly acts as the accumulator and uses the compressibility of the water to dampen the output water pressure pulsation caused by the reciprocation of the intensifier.

#### HP Filter (Optional)

The HP Filter Assembly (optional) is normally located at the pump output or at the upstream end of the whip for the cutting head.

Instructions are provided that detail the disassembly and reassembly of the hydraulic intensifier and HP seal maintenance. A detailed description of the inspection and repair for individual HP subassemblies are provided. HP attenuators are described but no disassembly procedures are included since the attenuators are not serviceable by the customer.



**WARNING**

**High-pressure water may be stored in the HP plumbing. Water pressure must be discharged through the bleed-down valve before starting any service or maintenance.**

**Stay clear of weep holes when unscrewing HP fittings in case pressurized water is discharged.**

**Turn off electrical power and relieve all water and hydraulic pressure prior to service. Proper lockout/tag-out procedures must always be followed prior to performing any maintenance.**



## 7.2 Intensifier

### Special Tools

In addition to any standard tools, the following special tools are required:

- 11557 Seal Insertion Tool Assembly (Includes: 11812 Push Tool, 11811 Sleeve Guide, 11550 Locating Ring, 12932 Spacer Tool)
- 11985 Seal Housing Removal Tool
- 300 ft-lb torque wrench with 3/4 in. square drive
- 1-1/2 Hex x 3/4 in. Square Drive Socket
- 3/4 in. Hex x 3/4 in. Deep Square Drive Socket
- 3/4 x 13-1/2 in. Hex Driver
- High Pressure Food Grade (H1) Lubricant



Due to the high forces inside the intensifier all bolts and cap screws that fasten the load carrying components are **Grade 8**. Fasteners that are exposed to cyclic loading use lock washers. Torque the load carrying fasteners to the correct **Torque Specifications** unless otherwise noted.



**Keep all interior parts and surfaces clean. All parts should be placed on clean work surfaces. When changing HP components such as HP seals, hands should be washed and kept clean. Before reassembling any high pressure or hydraulic components, verify that the components have been wiped clean to remove any dirt or other contaminants.**

## 7.3 High-Pressure Ends

### High-Pressure Seal Replacement

Replacing the high-pressure seals and hoops is the most common service function. Water dripping from either end of the HP cylinder indicates that the seals may soon require changing. One drip every few strokes means that the seals should be watched. More than one drip with each stroke means that the seals in that HP cylinder should be changed at the first opportunity.

This section will provide the basic information needed do in-house replacements and service on the high-pressure ends for the HyPrecision 100D/150D pumps. For any questions and all other service needs please contact 0.15"service representative.

The high-pressure end drawing shows the locations of the components and their part numbers. Always check the part list included with this manual for the latest parts and their replacement part numbers.



## Removing Old HP Seals

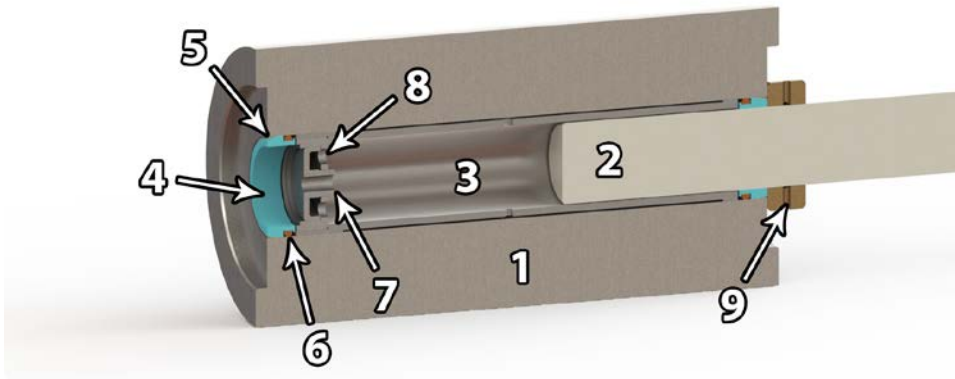

1. Remove the high-pressure tubing and inlet water quick-disconnects from the appropriate end of the intensifier.
2. Remove the four 1 in. nuts from the studs by using a cross pattern to gradually unload the high-pressure end cap from the high-pressure cylinder.
3. Remove the HP end cap and the check valve body from the HP cylinder.
4. Remove the HP cylinder (1) from the plunger (2) and the LP poppet (7) from the static end of the HP cylinder.



**The dynamic end of the cylinder is the end towards the intensifier center and the static cylinder end is the outboard side and contains the LP poppet.**

5. Place the stepped (static) end of the cylinder on the seal-tool locating ring. Use a rubber mallet at the small end of the push tool to drive the bottom seal and hoop out of the HP cylinder. Flip the cylinder over and repeat the process. The seals (4) with O-rings (6), hoops (5), spacer tube (3), and low-pressure poppet basket (8) should now be free of the HP cylinder.
  6. Remove the bronze seal backup (9) from the seal housing in the hydraulic end cap. It may require partially removing the seal housing. See the **Hydraulic Seal Housing** subsection of the **High-Pressure Water** section for housing removal instructions.
  7. Clean and inspect all disassembled parts. If the bronze seal backup (9) is to be reused, verify that the weep hole and ID groove are clear.
- \*See the **High-Pressure Cylinder** subsection for reconditioning of the HP cylinder and check valves.

## Installing New HP Seals

### Parts Needed:

- Seal replacement tools.
  - Seal kit: 4 HP seals with O-rings, 4 hoops, 1 grease packet, bronze seal backup.
1. Place the HP cylinder on the spacer tool, then insert the spacer tube, basket, and LP poppet
  2. Place the locating ring and seal guide on the end of the cylinder. The large ID end of the seal guide should be up. Coat the inner diameter of the seal guide with the packet grease.
  3. Apply grease from the packet onto each O-ring. Place each O-ring onto the HP seal while making sure that the O-ring does not twist.
  4. Place the seal with O-ring inside the seal guide with the O-ring toward the cylinder.
  5. Push the seal into the bore using the non-stepped end of the seal insertion tool. Always hold the seal guide firmly against the HP cylinder to prevent the O-ring from cutting as it enters the bore.
  6. Place the silver hoop in the seal guide with the sharp edge toward the cylinder.
  7. Use the non-stepped end of the seal insertion tool and a soft blow hammer to pound the hoop into place. The hoop is seated properly when the seal insertion tool bottoms out on the seal guide.
  8. Apply a small amount of grease from the packet around the OD of the pilot on the check valve body.
  9. Carefully insert the check valve body into the end of the high-pressure cylinder until it is seated firmly against the cylinder body. Do not apply any grease or blue goop to the check valve face or the cylinder bore, these are designed for dry contact.
  10. Flip the cylinder, place it securely on the check valve body, and repeat steps 3-5. Apply a very light coat of blue goop to the cylinder contact face.

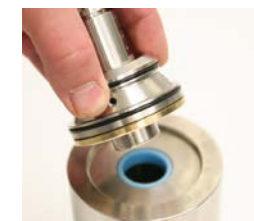
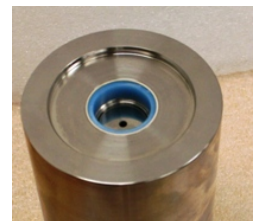

**IMPORTANT**

**Use a clean rag to wipe the interior of the LP basket so that there is no grease to make the LP poppet stick.**



**The bronze backup seal can be reused only once. Install either a new backup or reuse (flip) the old one. It may be necessary to pull the seal housing out slightly to access and remove the backup. (See the Hydraulic Seal Housing section.)**

## Reinstalling the High-Pressure Ends

1. Push the HP cylinder onto the plunger.
2. Place the HP end cap over the studs and make sure it guides smoothly onto the check valve body making sure to not unseat the O-rings on the check valve body.
3. Grease the stud threads with multi-purpose lithium grease such as Lubriplate No. 1552.
4. Using two 1 in. nuts located diagonally lightly torque the HP end cap so that it is bottomed onto the HP cylinder.
5. Torque the 1 in. nuts to 125 ft-lb. Then, using a cross pattern, increase torque in 50 ft-lb increments to 275 ft-lb.
6. Reattach the high pressure and low-pressure plumbing.
7. Turn the inlet water ON and open a cutting head. Allow the pump to cycle slowly at low pressure for a few minutes to ensure that the seals seat properly before returning to operating pressure.



## High-Pressure Cylinder

During normal use the inner surfaces at the ends of the HP cylinder may become worn. To clean this area roll polish the ID (Inside Diameter) of the cylinder ends on a table. First use 180 grit or finer abrasive paper, then finish with a Scotch-Brite pad.

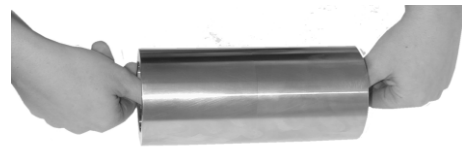

HP cylinders may eventually fail due to fatigue leading to a crack or the ends may open or bell out so that the cylinder does not hold the seal and hoop properly. If the cylinder is cracked it will be hot and water may squirt with each stroke. This failure may appear to be a seal failure. A belled out cylinder end will cause the premature failure of the seal and cause the hoop to break.

## 7.4 Check Valve Assembly

Check valve replacement and reconditioning is the second most common intensifier maintenance. The low-pressure check valve allows inlet water to enter the HP cylinder and the HP poppet lets the pressurized water from the HP cylinder exit the intensifier. Over time the faces of the poppet, seat, and check valve body may become worn.

The check valve repair process involves replacing the HP poppet (5), HP seat (7), poppet spring (6), and LP poppet (4), as well as lapping the face of the check valve body.

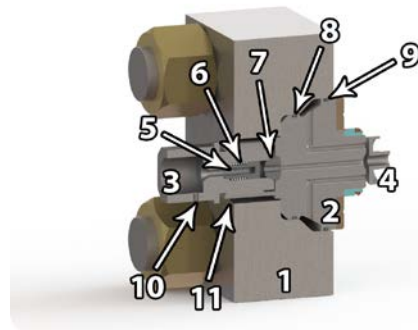

**Check valve repair may be necessary when the HP end cap area becomes hot to the touch or the intensifier strokes faster in one direction without seal leakage.**

## Weep Hole Leakage (See previous figure)

- Weep Hole #1 (10) leakage means that the inlet fitting needs to be tightened into the output adapter.
- Weep Hole #2 (11) leakage means that the output adapter needs to be tightened into the check valve body.

## Check Valve Replacement and Reconditioning

### Required Parts:

- Poppet kit, which includes: 1 HP poppet, 1 HP seat, 1 poppet spring, 1 LP poppet, 3 O-rings
  - High-pressure lubricant.
1. Remove the HP end cap (1) from the HP cylinder as described in the section on **Removing Old HP Seals**.
  2. Unscrew the output adapter (3) from the check valve body, remove, and discard the HP poppet (5), poppet spring (6) and the HP seat (7).
  3. Inspect the low-pressure poppet face of the check valve body (2). A worn face on the poppet (4) or check valve indicates that it should be lapped as described in the next section.
  4. Apply HP lubricant to **both** sides of the HP seat (7) and place the seat in the cavity of the check valve body (2).
  5. Install the poppet spring (6) and HP poppet (5) into the output adapter (3) and tighten the adapter into the check valve body (2).
  6. Replace the O-rings (8) (9) on the outside of the check valve body (2).
  7. Verify that the basket interior is free of grease.
  8. Replace the LP poppet (4) in the poppet basket located in the static end of the HP cylinder. Do not put any lubricant here. The lubricant may prevent the LP poppet from moving freely.
  9. Reassemble the end of the intensifier as described above in **Installing New HP Seals**.

## Check Valve Lapping Instructions

During use, the check valve body face (1) becomes worn from the action of the LP poppet. It may be indented from repeated poppet impact or have erosion tracks. This deformation will affect the sealing properties of this part. Periodically inspect this surface and if necessary use the lapping procedure to return it to a flat and near mirror finish. Proper lapping will help maintain the sealing properties and increase the life of the part.

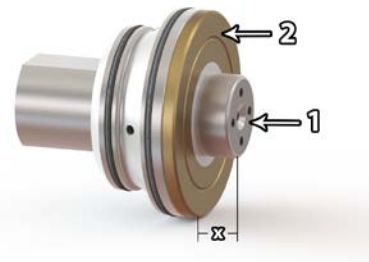

**Repeated lapping may shorten the check valve dimensions and render it unusable. If the sealing face is less than 0.385 in. from the body diameter area (dimension X), it should be replaced.**

This procedure is for a moderately worn check valve body face. Severe wear requires turning on a lathe or grinding on a precision surface grinder prior to lapping.

If the sealing face (1) has slight indentations only, use 1500 grit paper. Lapping is complete when the check valve body face is flat and has a near mirror finish.

Deeper indentations will need to be lapped with **600 grit SiC abrasive paper** first. Lapping is complete with this abrasive paper when the face has an even appearance and any indentations are removed.

The following items are required for the lapping procedure:

- Granite inspection plate at least 9 in. x 12 in.
- 8.5 in. x 11 in. sheets of 600 and 1500 grit SiC abrasive paper
- Lapping film

### Lapping Procedure:

1. Place either the abrasive paper or lapping film on the granite plate and secure the film in place with masking tape around the edges.
2. Hold the check valve flat against the abrasive surface to prevent any rocking of the part. Move the check valve body (2) back and forth on the film or paper. Rotate the valve 45 degrees after each movement until the face of the body (1) is evenly finished. **Repeat this procedure for the poppet face if needed.**



## 7.5 Hydraulic Seal Housing

Removing the hydraulic seal housing provides access to the rod seal. If oil is observed in the seal area during HP seal replacement, the rod seal should be replaced.

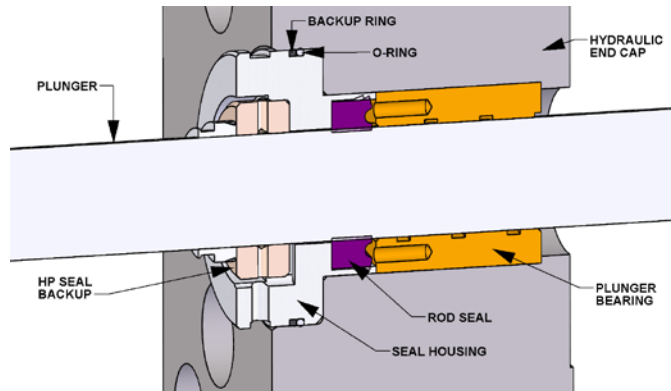

1. With the HP cylinder removed, slide the seal housing removal tool over the exposed seal-housing diameter and into the groove.
2. Use an Allen wrench to turn the two screws on the tool. Start with one turn to each screw to pull the seal housing evenly out of the hydraulic end cap.
3. Inspect the condition of the HP seal backup and flip or replace as necessary. Check for any inner diameter corner chipping or a loose fit on the plunger.
4. Remove the old seal from the seal housing.
5. Replace the O-ring and backup ring on the OD of the seal housing. Position the O-ring on the rod seal side of the groove and backup on the backup side of the groove. Note the position of the groove on the backup ring.
6. Apply HP lubricant to the outside of the O-ring and to the ID of the rod seal.
7. Apply a light coat of hydraulic fluid to the ceramic plunger and slide the Rod Seal over the end of the plunger. Note the orientation of the rod seal during installation.
8. Push and rotate the seal housing and rod seal over the plunger end until it is up against the end cap as far as it will go.

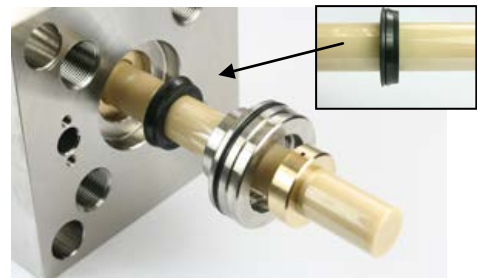
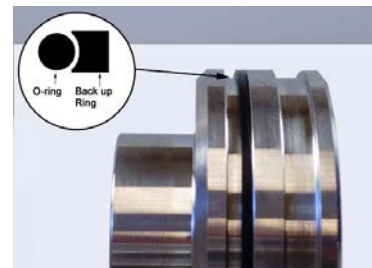
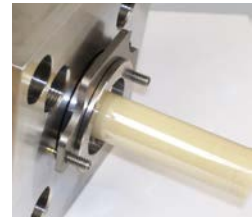



## 7.6 Hydraulic Center Section

The hydraulic center section houses the piston and the plungers. This section describes the service of this area with the HP cylinders removed and the center section removed from the pump.

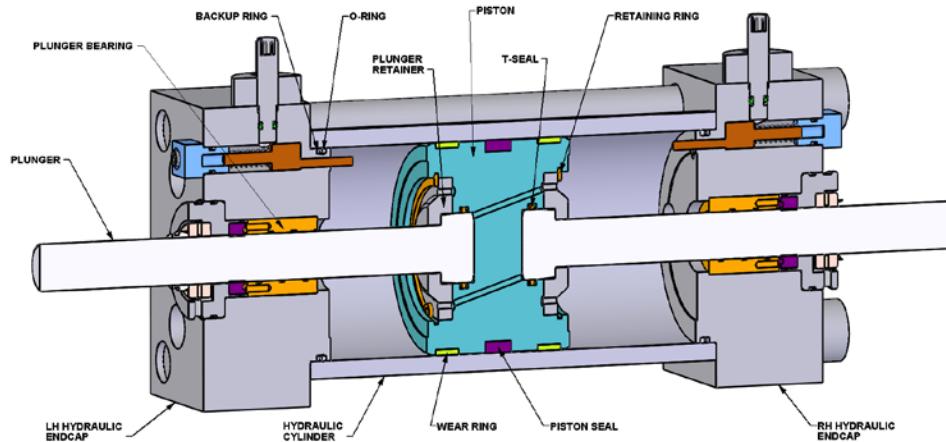

### Hydraulic Center Section Disassembly

1. Unscrew the eight bolts in the back of the manifold that connect it to the end caps.
2. With the HP cylinders removed, loosen but do not remove the four 7/8 in. cap screws that preload the two hydraulic end caps together. Use a 3/4 in. hex x 3/4 in. deep square drive socket and a 3/4 in. hex x 13-1/2 in. hex driver.
3. Unscrew and remove the four bolts under the hydraulic end caps that secure the intensifier assembly to the frame.
4. Place the center section on a clean workbench and remove the four 7/8 in. cap screws. Cover the manifold oil ports to prevent contamination.
5. Pull the end caps off the hydraulic cylinder. (This will take two people).

### Hydraulic Center Plunger Replacement

After extended use, the plunger surface may become damaged and/or scored.

1. Push the hydraulic piston to the end of the hydraulic cylinder so that the plunger is accessible. Use a rubber mallet to drive the opposite plunger end. Do not remove the piston from the cylinder. Special tooling is required to reload the piston into the cylinder.
2. Use locking snap-ring pliers on the retaining ring and remove the plunger retainer and plunger.
3. Replace the t-seal and its backups. The ID of the backup seal has a corner radius and should be towards the t-seal. The angle-cut ends of the backup must overlap properly.
4. Squirt a small amount of hydraulic fluid in the bottom of the piston cavity and lubricate the t-seal.
5. Push the new plunger into the t-seal, replace the plunger retainer, and reinstall the retaining ring.

## Piston Seal and Wear Ring Replacement

The piston uses a long life, capped t-seal and wear rings for the longest possible life. After extended use, the intensifier may not stroke efficiently and the pump will generate heat. This is a sign that the piston seal is bypassing oil and needs to be replaced. Special tools are required to load the new seal on the piston and load the new piston/seal assembly into the hydraulic cylinder. Contact an authorized Hypertherm service representative for further information regarding this procedure.

## Plunger Bearing

The plunger bearing may become worn and may lose its precision fit relative to the plunger. The bearing should be replaced if the plunger fit is too loose. A bearing ID measurement of **0.0015 in.** greater than the plunger diameter is considered too loose. The bearing can be changed when the hydraulic end cap is off the hydraulic cylinder. Repeated premature seal failure can be attributed to a worn out bearing. The bearing should also be replaced any time a high-pressure cylinder is replaced.

## Reassembling the Center Section

1. Verify that all surfaces are clean and free of contamination.
2. Replace the O-ring and backup on the end cap. Place the O-ring on the side of the groove towards the piston and the backup on the side away from the piston. The concave side of the backup is towards the O-ring. Lubricate the O-ring with hydraulic oil.
3. Install the plunger bearings in the end caps.
4. On a flat clean surface, slide the hydraulic end caps into each end of the hydraulic cylinder.
5. Thread the four 7/8 in. cap screws in and lightly pull the end caps against the hydraulic cylinder until they bottom-out. The cap screw threads should be greased with multi-purpose lithium grease such as Lubriplate No. 1552.
6. Secure the center section and manifold mounting face to a flat surface before applying torque to the 7/8 in. cap screws. Bolt it to the manifold first and then to the frame on the pump before applying torque.
7. Torque the 7/8 in. cap screws to **100 ft-lb**. Then increase torque in **50 ft-lb** increments using a cross pattern to **275 ft-lb**.



**The eight bolts that connect the manifold to the hydraulic end caps must be torqued to the appropriate value as given in the Torque Specifications section of this manual.**

8. Reassemble the end of the intensifier as described above in **Installing New HP Seals**.
9. When reconnecting the HP tubing loosen the four bolts that secure the intensifier to the frame. This will allow it to float into the correct location. Tighten the four frame connect bolts.



## 7.7 Intensifier Cycling

Under normal operating conditions, the intensifier is designed to cycle smoothly in both directions at the same speed.

Leaks or HP component failures will cause the intensifier to **overstroke** in one or both directions. Severe overstroking can cause a fault condition and/or a pump shutdown. An arrow on the display screen will indicate the direction of overstroke. If an overstroke shutdown or harsh cycling occurs, it is important to observe the pump operation before attempting to fix the problem.

- Turn on the pump and intensifier at a reduced cutting pressure of **1,000-psi** hydraulic pressure.
- Gradually increase the pressure until the nature of the problem is present.
- Use the proximity switch lights to determine which direction the intensifier is over cycling while looking for any leaks.

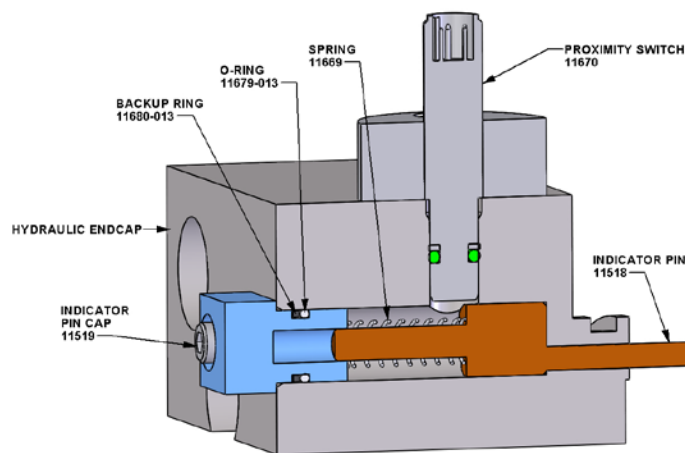

### End of Travel Sensing

When the hydraulic piston reaches the **end of travel** on either side of the cylinder it will push against an **indicator pin**. The proximity switch above the pin will sense the larger diameter of the pin as it passes under the switch. This pin should move freely in and out to the bottom of its travel. To gain access to the indicator pin remove the indicator cap from the end cap.



**Use the specified torque when reassembling the indicator pin cap and proximity switch.**

### Intensifier Overstroking Equally in Both Directions

Overstroking equally in both directions is most likely caused by a leak. Check the tubing and fittings inside and outside the pump and fix any leaks. Check the bleed-down valve. If the valve feels hot or if water is coming out the pump drain line then the bleed-down valve should be rebuilt with a new kit.

A blown orifice at the cutting head will also increase the HP water requirements.

The intensifier water inlet could be starved without setting off the low-pressure alarm. Check the quick disconnects to the intensifier to be sure all fittings are tight and no water is leaking.

## Intensifier Overstroking in One Direction

This indicates a problem inside the intensifier, specifically the LP poppet or HP check valve area. Verify that the inlet water is connected to the intensifier. Look for leaking from either end of the HP cylinder. Replace HP seals if necessary. If the HP cylinder or check valve body is hot, disassemble and look for cracks. Any component that is cracked must be replaced.

If there are no visible leaks from any weep holes then one of the poppet and seat areas may be bypassing water. Inspect both of the HP poppets and seats and both LP poppets. Inspect the check valve body-face. Replace and/or recondition the damaged poppet faces.

## 7.8 Pump Bleed-Down Valve

The pump bleed-down valve discharges high-pressure water from the pump when the pump is turned off. It operates as a normally-open safety valve and is controlled by an air-actuated valve. The bleed-down valve is located inside behind the utility panel at the front of the pump.

### Bleed-Down Valve Repair

The Bleed-Down Valve repair kit 12981 contains one each of the following:

- Seal Hoop 11323
- Needle(Stem) 12942
- Seal, FL 11321
- Bushing 11324
- Poppet Seat 11141

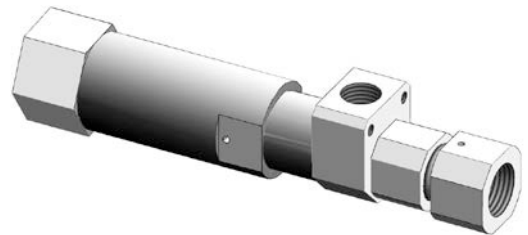

### Kit installation procedure:

1. Shut down the system.
2. Remove the hydraulic hose from the bleed-down valve and gland nut connection from the water drain tubing to the bleed-down valve.
3. Remove the gland nut from the collar at the high-pressure port of the bleed-down valve.
4. Disconnect the actuator from the high-pressure valve assembly. Remove all the hydraulic fittings from the actuator housing.
5. Remove the adapter from the bleed-down valve body. Remove and discard the HP seat.
6. Remove all the internal components from the bleed-down valve body.
7. Push the piston out of the actuator housing body through the oil port. Discard the o-ring and backup ring from the piston.
8. Clean all parts before the new parts are installed.
9. Lubricate the new o-ring and backup ring with grease from the supplied packet and install the rings in the same order as the old O-rings (previous figure). Install the piston assembly carefully into the actuator body until it is seated securely and no damage has been caused to the o-ring.
10. Secure the hydraulic fitting to the end of the actuator housing.
11. Apply Blue Goop to both sides of the HP seat and to the flow reducer and place them into the valve body as shown. Tighten the outlet adapter on the end to secure the parts.

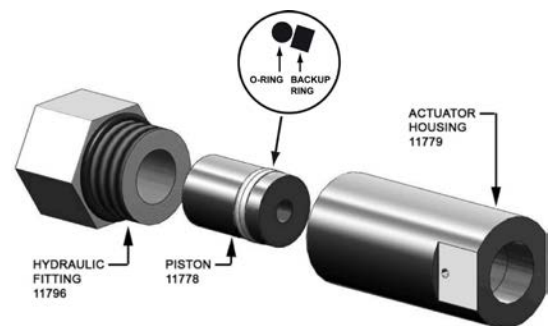

- Place the stem flat side out, into the backup screw. Place the stem bushing, hoop, and seal on the stem in the order shown below. The seal should fit into the hoop's sharp side. Use HP lubricant to lubricate the OD of the seal and o-ring before they are inserted into the valve body.
- Push the assembled parts into the valve body and use a 5/16 socket tool to screw the backup screw securely into the valve body.

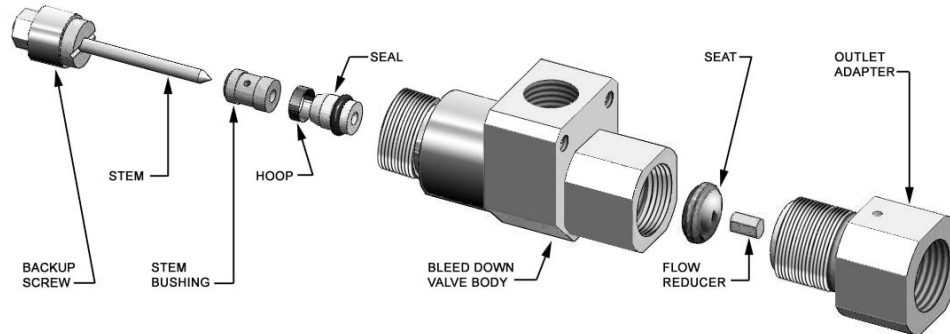

- Apply Blue Goop to the threads of the bleed-down valve body and secure the valve to the actuator housing.
- Reinstall the bleed-down valve in the machine by attaching the gland nut to the high-pressure collar at the high-pressure port of the valve. Torque the gland nut to 35 ft-lb.
- Install the gland nut connecting the water drain tubing to the bleed-down valve.
- Reattach the hydraulic hose to the oil port of the bleed-down valve.

The intensifier is now ready for use. Turn pump on and check for any leakage.

## 7.9 Attenuator

Hypertherm pumps are equipped with an attenuator with a volume of either 1 liter or 2 liters depending on the size pump.

The 1-liter attenuator uses 3/8 in. HP fittings. The 2-liter attenuator uses 9/16 in. male x 3/8 in. female inlet adapters on either end to connect to the 3/8 in. HP plumbing. Leakage from the inlet adapter or fitting weep holes can be addressed by tightening the adapters and fittings into the attenuator end caps.

Leakage from the end cap weep-hole or the gap between the end cap and the attenuator body is not serviceable by the user. If leakage persists from this area, contact a Hypertherm service representative for further assistance.

## 7.10 High-Pressure Filter Assembly (Optional)

The HP filter assembly is an optional product available to screen small particles of debris out of the high-pressure lines from the pump. The high-pressure filter is located at the output of the pump. It contains a screen filter element that should be replaced on a regular basis. See the **Scheduled Maintenance Chart** for a replacement timing guideline. The quality of water may increase or decrease the duration between filter element replacements. Always replace the filter at the recommended interval. Failure to replace the filter can result in the screen breaking which will release all trapped debris downstream into the high-pressure lines. This can cause orifice and valve damage.

## 7.11 High-Pressure Plumbing Weep Holes

Weep holes throughout the HP water system relieve the water seepage from any leaking components (for example, see **Check Valve Assembly**). Seepage from any of the holes indicates a faulty component, loose connection, or damaged seat. Failure to correct the cause may result in damage to the mating fittings.

If weep hole leakage is observed, the fitting may have loosened and it will need to be tightened. Another cause of seepage is the collar on the tubing may need to be threaded further onto the tubing. Persistent seepage may require replacing the fitting or tube.

Lubricate the high-pressure fittings with a HP grease such as Blue Goop. To minimize side load, use two wrenches to tighten the high-pressure fittings: one on the gland and the other on the fitting.

## 8 Hydraulic System

---

### Hydraulic Overview

Hydraulic pressure and flow from a pressure compensated variable displacement (PCVD) piston pump is passed through a spool valve where it is directed to either side of the hydraulic piston in the intensifier center section. The intensifier will reciprocate and create high-pressure water as output.

The pump compensator and the control manifold assembly control the hydraulic pump pressure. The manifold assembly is connected to the pressure compensator port on the pump. The control manifold has a pressure control valve for adjusting pierce pressure; the cut pressure is adjusted using the pump compensator. When the pump is turned off, a solenoid valve in the manifold opens and the hydraulic pressure goes to its minimum. Some pumps may have additional hydraulic components for electronic control of the pump pressure. Refer to the **Drawings and Parts Lists** section of the manual for detailed information on your pumps hydraulic circuit.

The larger pumps filter and clean oil using a "Kidney Loop". In systems with a kidney loop, the oil is drawn from the hydraulic tank through the gear pump mounted on the end of the PCVD pump. The oil then passes through the filter and heat exchanger before returning to the hydraulic tank.



**Before starting any service or maintenance, turn off electrical power and relieve all water and hydraulic pressure. Proper lockout/tag-out procedures must always be followed prior to performing any maintenance of the unit.**

### 8.1 Hydraulic Oil

#### Hydraulic Oil Requirements

Please reference chapter 9 for specific pump requirements.

#### Adding New Hydraulic Oil

Hypertherm intensifier pumps require ISO AW 32 or AW 46 mineral oil. Synthetic oil can also be substituted as long as it meets or exceeds the specifications of the mineral oil equivalent. To add new oil, follow this procedure:

1. Verify that the ball valve on the bottom of the hydraulic tank is closed.
2. Unscrew the filler/breather cover (1) on top of the hydraulic tank.
3. Fill with the appropriate oil until the oil level is visible at the top of the sight gauge at the front of the hydraulic tank. Do not overfill tank!
4. Replace the filler/breather cover (1).



#### Evaluating Old Hydraulic Oil

Oil quality can be estimated by the appearance or smell. New oil is almost clear and has no odor. When the oil color is like dark honey and it has a poor odor, it is time to replace the oil. A supplier can measure the oil quality more precisely. Water and/or high temperatures can damage the oil. Any time the oil is replaced, the hydraulic filter should also be replaced.

## High Temperature

Running the pump at a high oil temperature will shorten the oil life. Excessive oil temperatures will darken the oils color and its smell will worsen. The recommended oil temperature is under 130°F but not less than 100°F. The pump system will give a high temperature warning at 130°F and shutdown at 150°F. See the **Low-Pressure Water** section for instructions on adjusting the water-modulating valve for water/oil cooled units. Air/oil cooled units should not need any adjustment. If you are having chronic overheating conditions with an air/oil cooler contact a Hypertherm service representative for further instruction.

## Water Contamination

A milky oil appearance will indicate that there is water in the oil, or “water contamination”. If the hydraulic oil has been contaminated it can damage the hydraulic pump. The pump will need to be shut down immediately and the oil will have to be drained. Once the oil is drained, all the components must be cleaned. Water can be injected into the oil from the dynamic water seal in the intensifier. A badly leaking dynamic water seal can squirt water past the rod seal into the oil (see the **High-Pressure Water** section).

The oil, dynamic seal, and rod seal will need to be replaced. If you have water in your oil please report the incident to an authorized Hypertherm service representative to receive any additional instructions.

## Oil Replacement Procedure



**While changing the oil, consider thoroughly cleaning out the hydraulic system.**

Requires:

- Appropriately sized suction strainers
  - Appropriately sized return diffusers (if applicable)
  - Hydraulic Filter Element
  - New oil, provided by your supplier
1. Drain the oil from the hydraulic tank using the ball valve at the bottom of the tank.
  2. Remove the access cover of the hydraulic tank.
  3. Remove and discard the suction strainers in the tank.
  4. Thoroughly clean the tank interior. Make sure no particulates remain on the bottom.
  5. Install new suction strainers. **DO NOT** use Teflon tape or pipe dope.
  6. Drain the oil in the hydraulic hoses by disconnecting one end.
  7. Reinstall hoses.
  8. Replace the oil filter element. (See the **Oil Filter** section that follows).
  9. Close the ball valve drain and reinstall the tank access cover.
  10. Fill the hydraulic tank with new oil.
  11. Let the oil sit until any bubbles dissipate.
  12. Start the pump at low pressure and check for hose leaks.



In the case of severe contamination such as with water, drain and clean out other areas such as the shift valve, main manifold, and the hydraulic pump.

## 8.2 Control Manifold

The control manifold consists of two solenoid valves for high (5) or low (4) pressure selection, two pressure control knobs for setting of the high and low pressures, a small accumulator (1), and a gauge for the hydraulic pressure. The control manifold connects to the pump compensator port and has a connection to the hydraulic tank. Some HyPrecision pumps may be available with electronic pressure compensation. The following control manifold sections refer to pumps that do not have this option. For systems equipped with electronic pressure compensation contact Hypertherm for information on adjusting the pressure.

### Cutting Pressure Knob and Pierce Pressure Knob

The cutting pressure and pierce pressure knobs are located on the front of the control manifold and are used to adjust the cutting and pierce pressures. See the **Operation** section for instructions on setting the operating pressure.

#### Cut Pressure Select Solenoid Valve

The cut pressure select solenoid valve (5) is a normally open valve located on the back of the control manifold directly behind the cutting pressure knob. In the event of a power loss, the solenoid will discharge pressure from the hydraulic system and cause the bleed-down valve (2) to relieve high-pressure water. This solenoid has a manual override (3). If solenoid coil fails, the valve can be manually turned on until the coil is replaced.

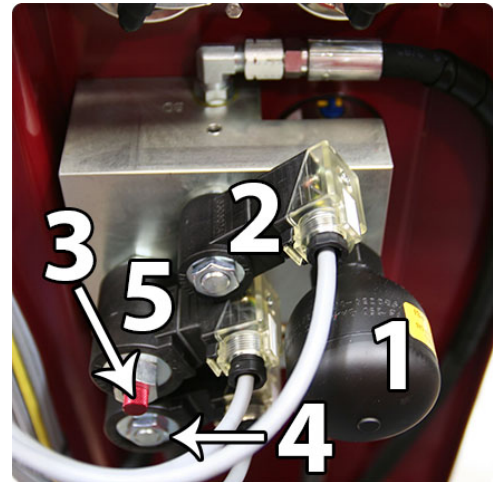

**WARNING**

Using the cut pressure select manual override will prevent the discharge of hydraulic and water pressure at shutdown. Pump pressure ramp-up will be abrupt. This feature should only be used as a temporary feature until a new solenoid coil is installed.

### Hydraulic Gauge

The hydraulic gauge shows the operating pressure of the system. It is also used to determine the current cutting water pressure. Multiply the gauge value by the intensification ratio of 19.25:1 to get the current water pressure. A gauge pressure of 3,000 psi will have the output pressure of about 57,000 psi.



## 8.3 Oil Filter

The oil filter is installed in line with the heat exchanger. The filter element should be changed when the oil is changed or at the maintenance interval given in the **Maintenance and Troubleshooting** section.

### Filter element replacement procedure:

Requires 1 - Filter Element

1. Unscrew the filter (1) from the top housing.
2. Discard the old filter element.
3. Install the new element according to the diagram that comes with the element.



## 8.4 Heat Exchanger

HyPrecision 100D/150D pumps are equipped with a water/oil heat exchanger and a gear pump. The gear pump is located on the end of the main motor and is part of the “Kidney Loop” system used for cooling the hydraulic oil. The type of cooling system will vary according to system size and customer preferences.

### Water/Oil Exchanger (Standard)

If your pump is equipped with the water/oil heat exchanger, the gear pump will deliver the oil to the hydraulic filter before going through the heat exchanger and back to the pump. The heat exchanger is sized for use with water.



**If you are using a chiller with water/glycol solution the efficiency of the heat exchanger will be reduced and may require reducing the temperature set point of a chiller.**

The oil temperature variations coming from the heat exchanger can be controlled by adjusting the flow rate of water. The flow rate of the water can be adjusted by either the water-modulating valve (if applicable) or a manual ball valve.

For directions on adjusting the water-modulating valve please refer to the **Low-Pressure Water** section of this manual.

For best long-term performance, the cooling water should be low in total dissolved solids (TDS). High TDS levels can lead to clogging and loss of efficiency in the heat exchanger.

### Air/Oil Exchanger (Optional)

If your pump is equipped with an air/oil cooler, the gear pump will deliver the oil through a one-inch external hydraulic hose to the air/oil cooler and back to the bulkhead on the pump. The cooler uses a radiator with an external fan powered by a fractional horsepower motor to cool the oil temperature to an acceptable range.

The air/oil cooler fan will automatically turn on once the hydraulic oil reaches the factory set temperature. Once running, the fan will remain on for a minimum of 10 minutes. If after 10 minutes, the oil is still above the preset temperature the fan will remain on until the oil has dropped below that temperature.



## **8.5 Hydraulic Tank**

The hydraulic tank has the following features:

- Sight gauge and thermometer for seeing the oil level and its temperature
- Filler/breather cap to keep the contents of the tank free of airborne contamination
- Level sensor with temperature switches which monitor the tank for low level and high temperature alarm conditions
- Inlet suction strainers to prevent contamination from reaching the main PCVD pump and the gear pump or kidney loop system.

## **8.6 Main Pump Setup**

Contact Hypertherm if the main hydraulic pump needs to be replaced. Detailed setup information is available upon request.



## 9 Specifications

The following specifications describe the requirements and capabilities of the AS-Series pumps.

### 9.1 Pump Requirements

	50hp (37kW)		60hp (45kW)		75hp (56kW)		100hp (75kW)		150hp (112kW)	
	50	60	50	60	50	60	50	60	50	60
Frequency (Hz)										
<b>Pump Power</b>										
Voltage (V)	400		230/460	230/460	400	460	400	460	400	460
Current (I)	70			135/67	105	95	150	120	215	170
Main C.B. Rating (I)	90			175/100	125	125	200	200	250	225
<b>Physical</b>										
Size	Width						80in (2.03m)		45 (1.15m)	
	Length						42in (1.07m)		86 (2.18m)	
	Height						58in (1.47m)		56 (1.42m)	
Clearance Height	80in (2.03m)					80in (2.03m)		80in (2.03m)		
Shipping Weight Approx. (in crate, no oil)	3200lb (1450kg)	3300lb (1497kg)		3400lb (1540kg)		4250lb (1928kg)		6250lb (2834kg)		
Operating Weight Approx.	3100lb (1406kg)	3200lb (1450kg)		3300lb (1497kg)		3300lb (1497kg) 4150lb (1882kg)		6100lb (2767kg)		
<b>Ambient Conditions</b>										
Min. Storage Temp. (not drained)	35°F (1.7°C)									
Min. Operating Temp.	40°F (4.4°C)									
Max. Operating Temp.	95°F (35°C) <b>Note: higher temperature operation available with additional cooling package</b>									
Max. Relative Humidity	95%									
<b>Inlet Cutting Water</b>										
Min. Inlet Water Pressure	40 psi (1.38 bar)									

Frequency (Hz)	50hp (37kW)		60hp (45kW)		75hp (56kW)		100hp (75kW)		150hp (112kW)	
	50	60	50	60	50	60	50	60	50	60
Max. Inlet Water Pressure (See LP Water section)	115 psi (7.72 bar)									
Max. Inlet Temp.	70°F (21°C)									
Min. Inlet Temp.	40°F (4.4°C)									
Min. Inlet Flow Rate	2 gpm (7.6 lpm)		2.5 gpm (9.5 lpm)		4 gpm (15.1 lpm)		<b>5 gpm (18.9 lpm)</b>			
Inlet Water Quality	See <b>Water Quality</b> section									
<b>Hydraulic Cooling Water (if not air cooled)</b>										
Min. Inlet Water Pressure	40 psi (2.76 bar)									
Max. Inlet Water Pressure (See LP Water section)	115 (7.93 bar)									
Max. Inlet Temp.	70°F (21°C)									
Min. Inlet Temp.	40°F (4.4°C)									
Normal Inlet Flow Rate	3 gpm (11.5 lpm)		4 gpm (15 lpm)		8 gpm (30 lpm)		10 gpm (38 lpm)			
<b>Hydraulics</b>										
Hydraulic Oil Type	ISO AW 32 or ISO AW 46 Mineral Oil									
Hydraulic Oil Capacity	38 gal (144 L)					55 gal (340 L)			96 gal (363 L)	
Max. Oil Temp.	130°F (55°C)									
Min. Oil Temp.	55°F (12.8°C)									

Pump Factory Settings		
Hydraulic Pump Pressure Limit	3200 psi (220 bar)	
Cut Pressure Set Point	Factory Set to Minimum Pressure for Startup. Adjust per startup operating instructions in this manual.	
Pierce Pressure Set Point	Factory Set to Minimum Pressure for Startup. Adjust per startup operating instruction in this manual.	
Utility Hook-Ups (located at rear of pump)		
Cooling In	1 NPT Female	
Cooling Out	1 NPT Female	
Cutting Water In	3/4 NPT Female	
Drain Water Out	3/4 NPT Female	
Cutting Water Out	3/8 HP Female	9/16 HP Female
Warnings and Shutdowns		
Intensifier HP Leak Warning	Warning	
Intensifier Over Cycle	Shutdown	
Inlet Cutting Water Under Pressure	P < 40 psi (2.8 bar) Shutdown	
Hydraulic Oil Level Low	Shutdown	
Hydraulic Oil Temp. Alert Temp	T > 131°F (55°C) Warning	
Hydraulic Oil Temp. Shutdown Temp	T > 150°F (65°C) Shutdown	
Motor Fault	Shutdown	

## 9.2 Pump Capabilities

	50hp (37kW)		60hp (45kW)		75hp (56kW)		100hp (75kW)		150hp (112kW)	
<b>Frequency (Hz)</b>	50	60	50	60	50	60	50	60	50	60
<b>Max. Continuous Output Pressure</b>	60,000 psi (4137 bar)									
<b>Min. Output Pressure</b>	8,000 psi (552 bar)									
<b>Max. Output Flow gpm (lpm)</b>	1.0 (3.79)	1.1 (4.16)	1.2 (4.54)	1.3 (4.92)	1.5 (5.68)	1.6 (6.05)	2.1 (7.95)	2.2 (8.33)	3.0 (11.4)	3.2 (12.1)

## 9.3 Orifice Combinations

This pump will support at least the following orifice sizes (sizes are in inches):

	50hp (37kW)		60hp (45kW)		75hp (56kW)		100hp (75kW)		150hp (112kW)	
<b>Frequency (Hz)</b>	50	60	50	60	50	60	50	60	50	60
<b>1 Orifice</b>	.014	.015	.015	.016	.017	.018	.020	.021	.024	.025
<b>2 Orifices</b>	.010	.010	.011	.011	.012	.013	.014	.015	.017	.018
<b>3 Orifices</b>	.008	.008	.009	.009	.010	.010	.011	.012	.014	.014
<b>4 Orifices</b>	.007	.007	.008	.008	.009	.009	.010	.010	.012	.013
<b>5 Orifices</b>	.006	.006	.007	.007	.008	.008	.009	.009	.011	.011
<b>6 Orifices</b>	N/A	N/A	.006	.006	.007	.007	.008	.008	.010	.010

## 9.4 Inlet Cutting Water Requirements

### Inlet Cutting Water Requirements and Testing

The inlet water should have a pH of 6 to 8 and be clear, odorless, and free of biological materials. To insure the incoming water will not have an adverse effect on the diamond life, the water quality can be tested with the TDS meter.

In other cases, it should be analyzed for the following:

- pH
- Silica Content
- Total Dissolved Solids (TDS)



## 9.5 Water Treatment Guidelines:

Testing your inlet cutting water with a TDS meter allows you to quickly and effectively monitor the quality of your inlet water and make adjustment accordingly.

<b>High Quality Water</b>	TDS < 50 ppm	No treatment required	No action
<b>Good Quality Water</b>	50 ppm < TDS < 150 ppm	Soften only	Contact local water treatment specialist
<b>Medium Quality Water</b>	150 ppm < TDS < 250 ppm	Soften or TDS removal	Specialist or RO system
<b>Poor Quality Water</b>	TDS > 250 ppm Silica > 15 ppm	TDS removal	RO System available through Hypertherm



**Do not treat to 5 ppm or less: Water of this high of purity is overly aggressive and will damage stainless steel components.**

## 9.6 Torque Specifications

This specification chart applies to all fasteners used to make hydraulic and high-pressure connections. This includes hydraulic flange fittings, proximity switch to end cap, hydraulic manifold to end cap, one-inch intensifier nuts, and intensifier center-section cap screws. Torque values are for lubricated **Grade 8** fasteners.

<b>Specific Torques:</b>	
Intensifier Stud: 1 in. nut	275 ft-lb (373 N-m)
Intensified Center: 7/8 in. cap screw	275 ft-lb (373 N-m)
<b>General Torques:</b>	
The torques below are to be applied only to those fasteners not listed above:	
#10	45 in-lb* (5.1 N-m)
1/4 in.	105 in-lb* (11.9 N-m)
5/16 in.	18 ft-lb (24N-m)
3/8 in.	33 ft-lb (45 N-m)
7/16 in.	53 ft-lb (72 N-m)
1/2 in.	80 ft-lb (108 N-m)
<b>High Pressure Fitting Torques</b>	
1/4 in.	15-25 ft-lb (20-34N-m)
3/8 in.	35-45 ft-lb (47-60N-m)
9/16 in.	60-75 ft-lb (80-100N-m)

\* 1 ft-lb = 12 in-lb



## 10 Maintenance & Troubleshooting

---

This section outlines the scheduled and preventative maintenance required to keep the intensifier pump in good working order. The following pages contain Parts and Service Contact Information, Maintenance Guidelines, a Scheduled Maintenance Chart, Troubleshooting guide, and a Maintenance Log.

### 10.1 Parts and Service Contact Information

Hypertherm, Inc.  
309 5th Ave NW  
New Brighton, MN 55112  
Toll Free: 866-566-7099  
Phone: 651-294-8600  
Fax: 651-294-8620  
Email: [info@Hypertherm.com](mailto:info@Hypertherm.com)  
Web: [www.Hypertherm.com](http://www.Hypertherm.com)

### 10.2 Maintenance Guidelines

The AS-Series pumps require preventative and scheduled maintenance to remain in good working order, prevent unscheduled downtime, and extend the life of the components. To provide safe and proper maintenance, read and follow all maintenance guidelines in this section.

- Always bleed down all high-pressure water and lock out the electrical control cabinet prior to performing any maintenance. Failure to do so can result in severe injury.
- A high-pressure water leak can cause major damage to anything in its line of fire. Always repair any leaks immediately to avoid damage to equipment and/or serious personal injury.
- Carefully read all of the safety guidelines in the **Safety** section of this manual. Read and understand the pertinent sections to the maintenance that you are planning to perform.
- Shut off the main disconnect. When the power is shut off, the bleed-down valve will open and bleed off high-pressure water stored in the discharge piping. Always double check to make sure that all high-pressure water has been discharged prior to servicing the pump.
- When servicing any electrical component of the pump always follow proper lockout/tag-out procedures. Remember that even when the main disconnect is off the lines coming to the pump are still hot unless shut off at their source.
- When servicing the cooling or cutting water assemblies, shut off water to the pump and drain the water in the accumulator by opening the ball valve to the left of the filters.
- Use catch pans under areas where water or oil may spill during the maintenance procedures.
- Always maintain a clean work area. Inspect and clean the pump regularly to spot issues before they become costly repairs. Always make repairs immediately. Keep a maintenance record.

## Scheduled Maintenance Chart

The following maintenance intervals are based on 4,000 hour per year operation. Less hours of use will increase maintenance interval length.

		As required	Per shift	Weekly	Monthly	3 months	6 months	Yearly
Electrical System	Inspect all cables and plugs for damage		I					
	Check safety circuits			I				
	Grease motor bearings							R
Low Pressure Water	Inspect fittings and hose for damage		I					
	Adjust cooling water flow	A						
	Check inlet water pressure		I					
	Inlet water filters		I				R	
	Check pressure in water accumulator – set to 40 psi							I
High Pressure Water	Visually inspect for leaks		I					
	Check temperature of intensifier and bleed down valve		I					
	Lap or replace LP poppet and check valve face	R						
	Replace HP seals	R						
	Replace HP filter at pump outlet				I		R	
	Replace hydraulic rod seal	I						R
	Replace plunger bearing	I						R
Hydraulics	Change oil filter (sooner if bypass occurs)						R	
	Change oil			I				
	Check oil level			I				
	Check oil temperature			I				
	Check for oil leaks			I				

A – Adjust I – Inspect R – Replace

## 10.3 Troubleshooting

The following troubleshooting chart lists symptoms, possible causes, and recommended solutions for troubleshooting the HyPrecision 100D/150D Intensifier Pumps. If you have corrected the fault condition and still receive a fault message, reset the pump by pressing the **FAULT RESET** button on the front control panel. This will clear the fault and allow you to re-start the pump.

### Fault Display Error Message

#### Hydraulic Oil Level Low

The oil level has dropped from a leak at a fitting or from performing maintenance on the hydraulic assembly.	Inspect the fittings and components of the hydraulic system for leaks. After identifying the cause of lost oil, add oil per instructions in the <b>Hydraulic</b> section of this manual.
Cable may be damaged or connector is unplugged.	Replace cable if damaged. Plug in connector if unplugged.

#### Hydraulic Oil Temp > 130F (55C) or Hydraulic Oil Temp > 150F (65C)

Air/Oil Cooled Unit – Fan motor starter tripped or off.	Turn dial to reset and back to run. Determine what caused the overload to trip if tripped.
Water/Oil Cooled Unit - Inlet cooling water to the pump not turned on.	Turn on inlet cooling water. Read the <b>Low-Pressure Water</b> section of this manual.
Water/Oil Cooled Unit - High cooling water inlet temperature.	Test the temperature of the inlet water. If the temperature is outside of the normal range outlined in the <b>Specifications</b> section of this manual, you may need a water chiller.
Water/Oil Cooled Unit - Cooling water flow rate may not be high enough.	Check the flow rate by monitoring the cooling water out. If the flow rate is too low then adjust the water-modulating valve or manual ball valve. See the <b>Low-Pressure Water</b> section of this manual.
Cable may be damaged or connector is unplugged.	Replace cable if damaged. Plug in connector if unplugged.
Heat exchanger could be clogged.	Repair or replace heat exchanger.

#### Inlet Water Pressure Below 40 psi (2.8 bar)

Inlet cutting water to the pump not turned on.	Turn on inlet cutting water. Read the <b>Low-Pressure Water</b> section of this manual.
The cutting water solenoid may be shorted.	If the coil or wire is damaged, replace it and restart the pump.

#### Intensifier Overstroke (pay attention to arrow direction)

The intensifier stroking too quickly in one or both directions causes this error. (There may be other possible causes for this error).	Note the direction of the intensifier over cycle and refer to Intensifier Cycle in the <b>High-Pressure Water</b> section of this manual.
--	---

## Motor Fault

Fuse in the control has blown. A short in a device on the PLC output may have failed causing the fuse to blow. A less likely scenario would be a short in the motor wiring for the boost motor or main motor.	Check the devices on the PLC outputs to determine what caused the fuse to blow. If it is a failed solenoid, usually you will see the plastic body deformed from heat. Check all cables for damage. Replace any faulty parts.
The main motor thermal overload (OL-MAIN) may have tripped.	Reset by pushing the reset button on the thermal overload. Refer to <b>Electric Motors</b> in the <b>Electrical System</b> section of this manual.

## Too Many Motor Starts Per Hour

The motor has been started too many times in 15 minutes.	Reset the alarm by pressing the FAULT RESET button on the control panel. Wait 15 minutes to let the motor armature cool down before starting again.
--	---

## Hydraulic pump does not make pressure or makes low pressure.

Defective cut pressure select solenoid.	Manually over-ride valve until replacement arrives.
Defective cut pressure control valve.	Replace valve.
Defective hydraulic pump and/or compensator.	Replace pump.
Defective relief valve.	Replace valve.
Pierce pressure is enabled.	Change pierce pressure to cut pressure at the display.

## Pump will not start.

Power disconnected.	Reconnect power.
	Check main disconnect.
E-Stop depressed.	Pull out all E-stop buttons.
Pump enclosure door open.	Close door and properly latch disconnect handle.
Motor overload relay tripped.	Check and correct.
	Adjust volume stop on pump.
Line fuses blown or missing.	Check and correct.
Pump remote key switch in wrong position.	Change key switch position.

## Intensifier Operation

### Intensifier does not cycle.

On/Off valve for cutting head is off.	Turn cutting head on.
Intensifier is disabled.	Enable intensifier at display.
Defective shift valve or end of travel proximity switch.	Replace if necessary.
One of the indicator pins is hung up as shown by both proximity switch lights on at the same time.	Disassemble and repair. Pins must move freely to bottom of bore.
Proximity switch has failed. Indicated by both proximity lights being on at the same time.	Replace proximity switch.

### Intensifier cycles and oil pressure okay but not enough pressure at head.

Clogged high-pressure filter.	Replace HP element.
Partial obstruction in HP lines.	Correct obstruction.
Worn hydraulic piston seal.	Rebuild hydraulic center section.
Too much demand on pump.	Reduce number or size of orifices.

### Intensifier overstrokes or cycles unevenly.

Various reasons.	See <b>Overstroke</b> section in <b>High-Pressure Water</b> .
------------------	---

## High-Pressure Cylinder and Check Tube

### Bronze backups have short life.

Worn plunger bearing.	Replace plunger bearing.
-----------------------	--------------------------

### Cylinder end drips and is hot.

Check for crack at end of HP cylinder.	Replace HP seals and hoops and HP cylinder if necessary.
--	--

### Check valve is hot and HP cylinder end drips.

Check for crack in check valve body.	Replace HP seals and hoops and check valve body if necessary.
--------------------------------------	---

### Check valve is hot and HP cylinder end does not drip.

Leaking HP poppet and seat.	Replace.
Leaking LP poppet and check valve body face.	Replace or repair.

### End of HP cylinder drips.

Worn HP seal.	Replace HP seals and hoops.
---------------	-----------------------------

### Hydraulic center section is much hotter than hydraulic oil.

Piston seal is worn.	Rebuild center section.
Piston seal has just been replaced and needs breaking in.	No action required.

### HP seal is short.

Poor mating surfaces.	Inspect, repair and/or replace HP cylinder ID and plunger.
Pump has cycled roughly.	Start-up new seals carefully.
Pump over cycled.	Check demand on pump.
Worn bronze back-up or bearing.	Replace backup or bearing.
Cylinder end too hot.	Correct problem. Refer to the <b>High-Pressure Water</b> section of the manual.
Hoops are broken from belled out HP cylinder end.	Replace HP cylinder when necessary.

### Oil present in dynamic end of HP cylinder.

Leaky hydraulic rod seal.	Replace rod seal.
---------------------------	-------------------

## 10.4 Maintenance Log

PUMP MODEL _____		SERIAL NO. _____
Problem found and work performed		
Date: _____		Initials
Hours: _____		_____
Date: _____		Initials
Hours: _____		_____
Date: _____		Initials
Hours: _____		_____
Date: _____		Initials
Hours: _____		_____
Date: _____		Initials
Hours: _____		_____
Date: _____		Initials
Hours: _____		_____
Date: _____		Initials
Hours: _____		_____
Date: _____		Initials
Hours: _____		_____
Date: _____		Initials
Hours: _____		_____
Date: _____		Initials
Hours: _____		_____
Date: _____		Initials
Hours: _____		_____
Date: _____		Initials
Hours: _____		_____

PUMP MODEL _____		SERIAL NO. _____
Problem found and work performed		
Date: _____		Initials _____
Hours: _____		
Date: _____		Initials _____
Hours: _____		
Date: _____		Initials _____
Hours: _____		
Date: _____		Initials _____
Hours: _____		
Date: _____		Initials _____
Hours: _____		
Date: _____		Initials _____
Hours: _____		
Date: _____		Initials _____
Hours: _____		
Date: _____		Initials _____
Hours: _____		
Date: _____		Initials _____
Hours: _____		
Date: _____		Initials _____
Hours: _____		
Date: _____		Initials _____
Hours: _____		
Date: _____		Initials _____
Hours: _____		
Date: _____		Initials _____
Hours: _____		
Date: _____		Initials _____
Hours: _____		
Date: _____		Initials _____
Hours: _____		



## **11 Drawings & Parts Lists**

---



## **12 Controls Manual**

---

14944 HyPrecision Color Touchscreen PLC Operations Manual





# HyPrecision Color Touchscreen PLC Operations Manual



**Models:**

**HyPrecision 50S, 60S, 75S, 100D, 150D**

# HOME

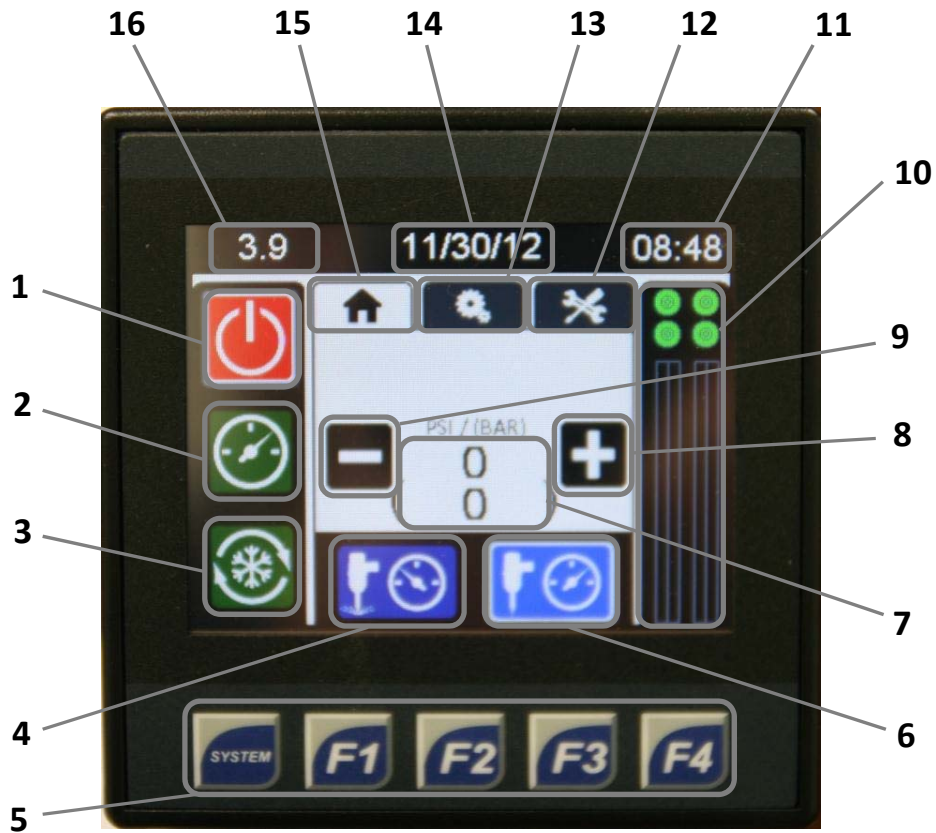

## Functions:

- |                                       |  |
|---------------------------------------|--|
| 1. Pump Off                           | 9. Decrease Water Pressure (Optional)  |
| 2. Pump On                            | 10. Intensifier/Pump Status Indicators |
| 3. Cooling On                         | 11. Time                               |
| 4. Low Pressure (Pierce)              | 12. Maintenance Menu                   |
| 5. PLC Hotkeys                        | 13. Settings Menu                      |
| 6. High Pressure (Cut)                | 14. Date                               |
| 7. Water Pressure (Optional)          | 15. Home                               |
| 8. Increase Water Pressure (Optional) | 16. Hour Meter                         |

# HYPRECISION COLOR TOUCHSCREEN PLC

Information in this manual pertains to operation, setup, and maintenance logging of Hypertherm HyPrecision Pumps. This guide is organized to help the operator navigate through the control screens and make any necessary adjustments or maintenance entries. If you have problems with the PLC unit or programming, please contact Hypertherm technical support at 1-866-566-7099.

## HOME



The **Home** screen will display multiple function buttons as well as the current date, time, and motor running time. The Home screen is the first screen to display when the system is turned on. Select the hotkey **F1** from any other screen to return to this Home screen. F1 will not return you to the Home screen when the pump is in either **Pump On** or **Cooling On** mode.



**Pump Off** will disable the intensifier and/or turn the electrical motor off from both the Pump On and Cooling On modes. Pump Off will function in both local and remote modes.



**Pump On** turns the electrical motor on and enables the intensifier(s). During the Pump On mode, the pump will build up pressure to the set point defined in the PLC (proportional control) or via the control knobs near the pressure gauges (manual control).



When the pump is in run mode, there will be an intensifier graphic on the main screen that strokes to the left and right to indicate the pump is on.



**Cooling On** turns the electrical motor on with the intensifier(s) disabled. The hydraulic system will run at minimum pressure to allow hydraulic fluid to cycle through the gear pump and cooling system.



**Low Pressure** places the pump in pierce mode and will briefly open the bleed down valve to adjust pressure to the setting defined in the PLC (proportional control) or with the pierce control knob (manual control).



**High Pressure** places the pump in cut mode and is set in the PLC (proportional control) or with the cut control knob near the pressure gauges (manual control)

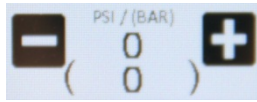

**Pressure Adjustment** (proportional control only) allows the user to adjust the water pressure when the pump is running. When the pump is in Pump On mode, pressing the minus or plus buttons will lower or raise the pressure within the limits of the machine (0-60000 PSI\*\*). This pressure will be adjusted for each pump mode (low pressure or high pressure) and saved internally in the PLC. The pressure can also be adjusted through the settings menu to establish preset points for cut and pierce (see SETTINGS). The main screen pressure adjustment overrides these values and the new values will be stored after adjustment is completed.

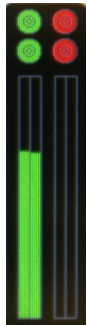

**Intensifier/Pump Status Indicators** show which pump(s) and intensifier(s) are enabled or disabled. These indicator bars will also show stroke rates to the left and right for each intensifier. The bars are color coded to provide easier reading (Figure 1). A green bar indicates a stroke rate within the allowable range. A yellow bar indicates a stroke rate at the limit of the allowable range. A red bar indicates a stroke rate greater than the allowable range and will cause an overstroke shutdown if stroking occurs for a set number of times. This bar graph is useful in determining which intensifier and which side of the intensifier caused the issue and may need maintenance.

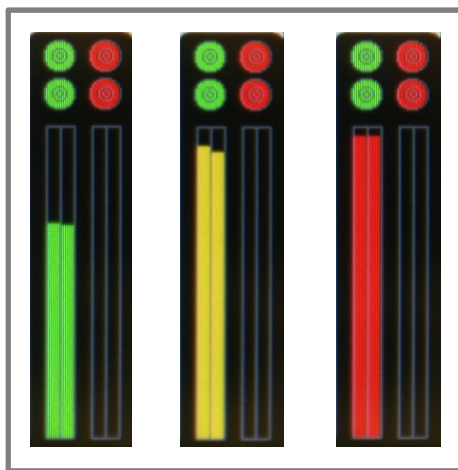

Figure 1. Intensifier stroke rate monitoring includes three levels/colors. A green indicates normal, yellow indicates at the overstroke threshold, and red indicates the intensifier is overstroking.

The indicator bars for each intensifier show which side is stroking faster or slower as well as the relation of the stroke rate to the overstroke threshold. Intensifier 1 is represented with the left two bars and intensifier 2 with the right two bars. The left bar of each set (intensifier 1 and 2) represents the stroke to the left. The right bar represents the stroke to the right. Comparing the two bars will determine if the intensifier is stroking at the same rate to the right versus the left. For example, the second graph in figure 1 (yellow bars) show that the intensifier was stroking faster to the left versus the right. The bars for intensifier 1 and 2 can also be compared to determine if the intensifiers are balanced correctly or if one intensifier is stroking faster than the other (dual intensifier pumps only).

\*\*Actual minimum pressure is between 8,000-10,000 PSI



# SETTINGS



## Functions

1. Intensifier Settings
2. Time/Date Settings
3. MicroSD Card
4. Pump Settings

## SETTINGS



The **Settings** screen will display the same function buttons as the main screen as well as several settings options for pump and intensifier setup. Pump Off, Pump On, and Cooling On are all selectable from the settings menu.



**Intensifier Settings** allows the user to enable or disable the intensifier(s) and pump(s) as well as set the overstroke percentage. A higher overstroke percentage will increase the allowable stroke rate prior to triggering an intensifier overstroke shutdown. This setting is factory set to 5% but should never be more than 20%. Pumps and intensifiers can be enabled or disabled by pressing on the color dot (red or green; Figure 2). A red dot means the component is disabled, a green dot means enabled. The Intensifier Settings menu is also available by pressing on the Intensifier/Pump Status Indicators side bar.



Figure 2. This screen is used to enable/disable the intensifier(s) and pump(s) and adjust the overstroke percentage. Red represents disabled and green represents enabled.



**Time/Date Settings** allows the user to set the current date and time. The user is also able to select the date layout (mm/dd/yy or dd/mm/yy).



The **MicroSD Card** button gives the user access to the contents on the storage card including the current program, alarm logging files, and maintenance logging files. There is limited functionality through this button (e.g., cannot save program). If more in depth access to the card is needed, contact Hypertherm technical support for assistance.



**Pump Settings** provides access to the system settings menu as well as current pump configuration and pressure adjustment.

# PUMP SETTINGS



## Functions

1. System Settings
2. Model Configuration
3. Pressure Adjustment

## PUMP SETTINGS

The **System Settings** page allows the user to enable and disable pump options (Table 1). The user is also able to adjust proportional ramping settings (proportionally controlled pumps only).

Table 1. This table provides explanations of the various system settings available through the pump settings menu.

Name	Description
Idle Shutdown	When enabled, the pump will shut down automatically after a specified time has elapsed without the intensifier stroking.
Idle Cooling	When enabled, the pump will shift into cooling mode automatically after a specified time has elapsed without the intensifier stroking.
Idle Time (minutes)	Amount of time that must elapse prior to the pump automatically shutting down when Idle Shutdown is enabled.
Analog Pressure Input	Disabled for most applications. Enable when a remote 0-10 volt input will be used to control the proportional valve for water pressure.
Boost Fault Monitor	Enabled for most applications. Provides fault monitoring in the PLC to alert the operator of a boost motor fault.
Fan Fault Monitor	Enabled for air over oil coolers. Provides fault monitoring in the PLC to alert the operator of a fan motor fault.
Web Remote Enable	Allows the pump to be remotely controlled through a web interface. Remote mode must be active for this option to work.
T(sec) for BDV Dump	Amount of time that the bleed down valve will open when shifting from cut to pierce to relieve excess pressure.
Max Pressure	Maximum pressure (PSI) that the pump can be operated at. This is only applicable for proportional controlled pumps.
Inc Interval (.1 Sec)	Amount of time between steps during ramping up when manually adjusting the pressure via the PLC on proportional controlled pumps.
Dec Interval (.1 Sec)	Amount of time between steps during ramping down when manually adjusting the pressure via the PLC on proportional controlled pumps.
Inc Amount (PSI)	Step amount for increasing pressure. (Default is set to 500 PSI per step)
Dec Amount (PSI)	Step amount for decreasing pressure. (Default is set to 500 PSI per step)
Init Jump Inc/Dec	Initial jump amount for increasing or decreasing pressure (Default is set to 500 PSI)
Real Ramp Setpoint	Setting that controls how quickly the pump will ramp up to the specified pressure. The higher the number, the faster it will ramp. (Default is 10)
Modbus Mode	Disabled for most applications. Enable when the pump will be controlled via Modbus TCP over Ethernet.

**Model Configuration** provides the user with the current pump setup information.

**Pressure Adjustment** allows the user to enter a pressure setting for cut and pierce that the pump will ramp up to when turned on. This setting will be overridden if manually adjusted on the main screen. The new pressure (after adjustment) will be saved into these settings. This is an option that is only applicable for proportionally controlled pumps.

# MAINTENANCE

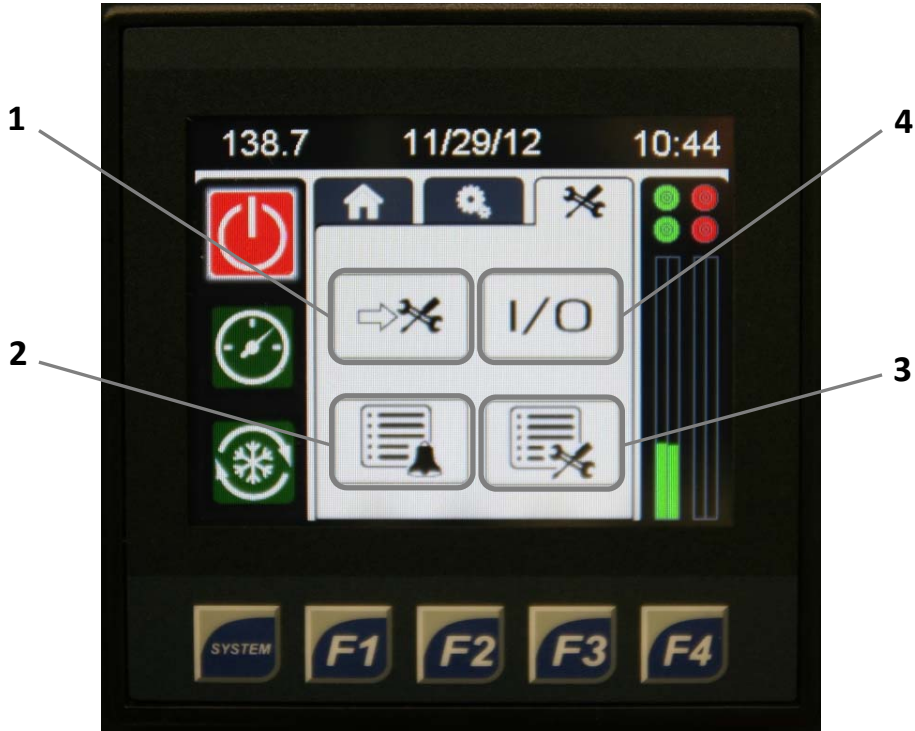

Functions

- 1. Pump Maintenance
- 2. Alarm Log
- 3. Maintenance Log
- 4. Inputs/Outputs Status

# MAINTENANCE



**Pump Maintenance** allows the user to log and track all maintenance performed on the pump and intensifier. The user is also able to shift the intensifier(s) left or right while in cooling mode using this menu.



To enter maintenance in the **Maintenance Logging** section, press on the applicable area of the pump and select the area maintenance was conducted (see following figures). Select each component that was replaced or worked on and the reason for the maintenance. This information will then be entered into the Maintenance Log for later viewing.



**Alarm Log** brings up the listing of all alarms in the pumps history and when they occurred. This can be extremely helpful in problem solving.

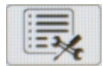

**Maintenance Log** lists all maintenance performed on the pump and also includes the date and time the maintenance was logged.

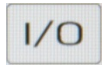

The **Inputs/Outputs Status** (Figure 3) provides a list of all inputs and outputs on the PLC and whether they are on or off. These can be helpful for troubleshooting.

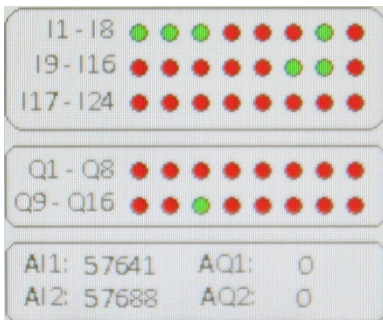

Figure 3. Inputs and outputs are listed as on or off based on the color. Red is off and green is on.

# PUMP MAINTENANCE



## Functions:

1. Intensifier 1 Shift Left
2. Intensifier 2 Shift Left
3. Maintenance Logging
4. Intensifier 2 Shift Right
5. Intensifier 1 Shift Right

# MAINTENANCE LOGGING



## Functions:

1. Back to Pump Maintenance
2. Main Pump Maintenance
3. Intensifier Maintenance



# MAIN PUMP MAINTENANCE



## Functions:

1. Replaced Hydraulic Filter
2. Greased Electric Motor
3. Back to Maintenance Logging
4. Replaced Hydraulic Oil
5. Replaced Water Filters

# INTENSIFIER MAINTENANCE

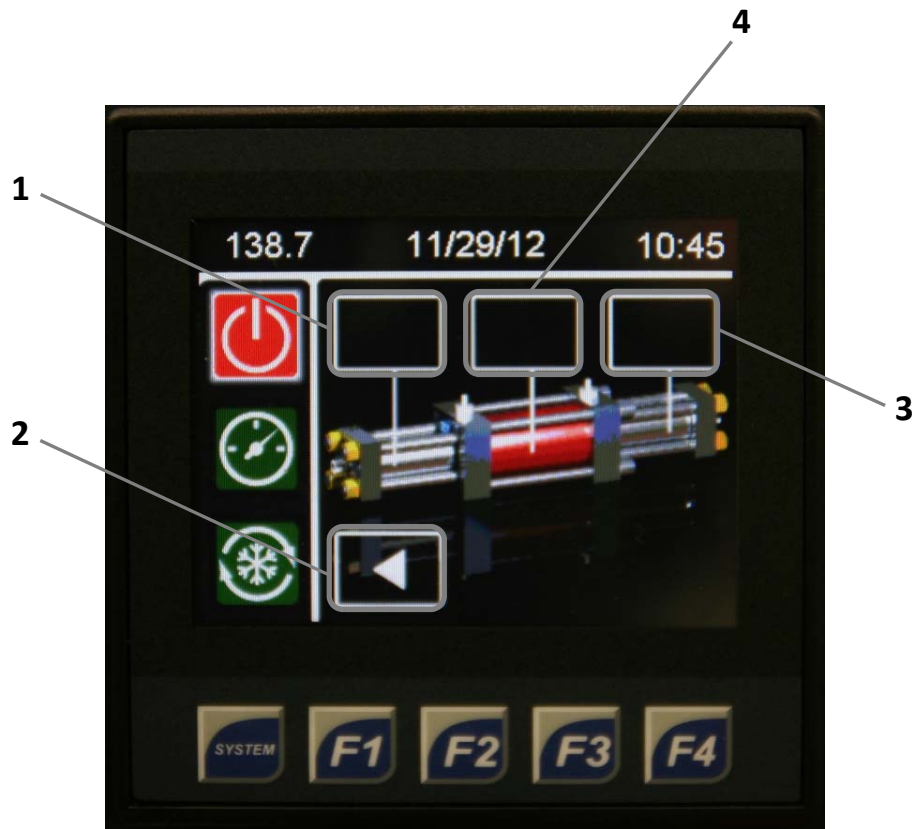

## Functions:

1. Left High Pressure Maintenance
2. Back to Maintenance Logging
3. Right High Pressure Maintenance
4. Center Section Hydraulic Maintenance

# LEFT/RIGHT HIGH PRESSURE MAINTENANCE



## Functions:

1. Replaced High Pressure Seals
2. Lapped Check Valve
3. Back to Intensifier Maintenance
4. More Maintenance Options
5. Replaced Hydraulic Rod Seal
6. Replaced Poppets (Low and High Pressure)

# LEFT/RIGHT HIGH PRESSURE MAINTENANCE



## Functions:

1. Replaced Bronze Backup
2. Replaced Check Valve
3. Previous Maintenance Options
4. Replaced Plunger Bearing
5. Replaced High Pressure Cylinder
6. Replaced Low Pressure Poppet Basket

# CENTER SECTION HYDRAULIC MAINTENANCE

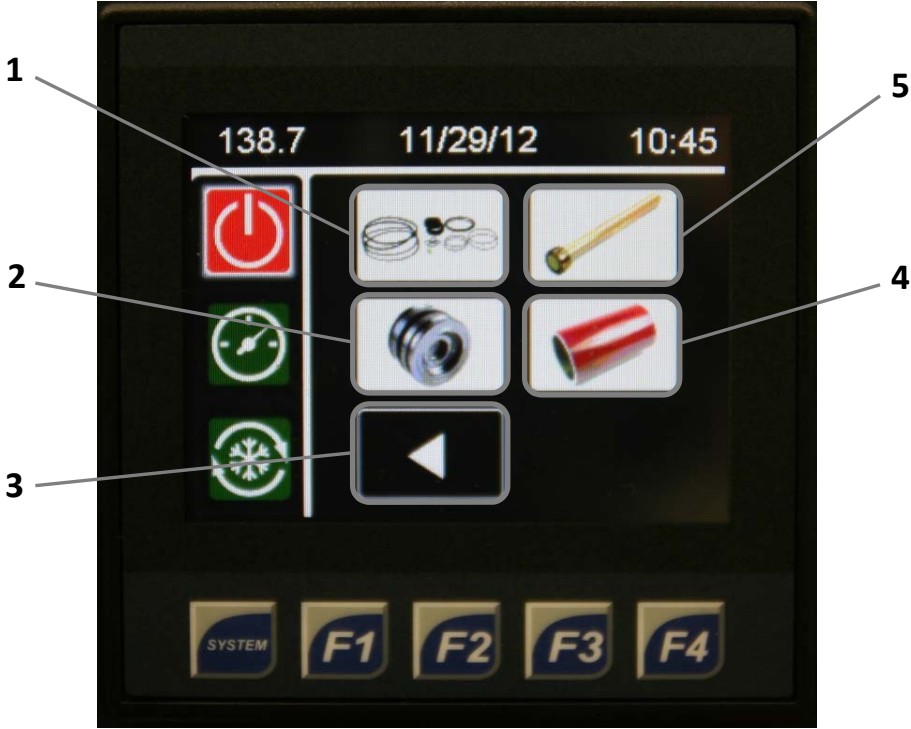

Functions:

- 1. Replaced Low Pressure Seals
- 2. Replaced Hydraulic Piston
- 3. Back to Intensifier Maintenance
- 4. Replaced Low Pressure Cylinder
- 5. Replaced Plunger

# REASON FOR MAINTENANCE



## Functions:

1. Component Leaking
2. Component Worn
3. Back to Maintenance Options
4. Other Reason
5. Component Cracked
6. General/Preventative Maintenance