

Hypertherm®

HyPrecision 50S/60S/75S™

Waterjet Pump



Operator Manual

808690 | Revision 2 | English

HyPrecision, AccuStream, and Hypertherm are trademarks of Hypertherm Inc. and may be registered in the United States and other countries. All other trademarks are the property of their respective holders.

One of Hypertherm's long-standing core values is a focus on minimizing our impact on the environment. Doing so is critical to our, and our customers', success. We are always striving to become better environmental stewards; it is a process we care deeply about.

© 2016 Hypertherm Inc.

HyPrecision 50S/60S/75S

Operator Manual

808690
Revision 2

English
Original Instructions

August 2016

Hypertherm Inc.
Hanover, NH 03755 USA
www.hypertherm.com

Hypertherm Inc.

Etna Road, P.O. Box 5010
Hanover, NH 03755 USA
603-643-3441 Tel (Main Office)
603-643-5352 Fax (All Departments)
info@hypertherm.com (Main Office Email)

800-643-9878 Tel (Technical Service)

technical.service@hypertherm.com (Technical Service Email)

800-737-2978 Tel (Customer Service)

customer.service@hypertherm.com (Customer Service Email)

866-643-7711 Tel (Return Materials Authorization)**877-371-2876 Fax (Return Materials Authorization)**

return.materials@hypertherm.com (RMA email)

Hypertherm México, S.A. de C.V.

Avenida Toluca No. 444, Anexo 1,
Colonia Olivar de los Padres
Delegación Álvaro Obregón
México, D.F. C.P. 01780
52 55 5681 8109 Tel
52 55 5683 2127 Fax
Soporte.Tecnico@hypertherm.com (Technical Service Email)

Hypertherm Plasmatechnik GmbH

Sophie-Scholl-Platz 5
63452 Hanau
Germany

00 800 33 24 97 37 Tel
00 800 49 73 73 29 Fax

31 (0) 165 596900 Tel (Technical Service)**00 800 4973 7843 Tel (Technical Service)**

technicalservice.emea@hypertherm.com (Technical Service Email)

Hypertherm (Singapore) Pte Ltd.

82 Genting Lane
Media Centre
Annexe Block #A01-01
Singapore 349567, Republic of Singapore
65 6841 2489 Tel
65 6841 2490 Fax
Marketing.asia@hypertherm.com (Marketing Email)
TechSupportAPAC@hypertherm.com (Technical Service Email)

Hypertherm Japan Ltd.

Level 9, Edobori Center Building
2-1-1 Edobori, Nishi-ku
Osaka 550-0002 Japan
81 6 6225 1183 Tel
81 6 6225 1184 Fax
HTJapan.info@hypertherm.com (Main Office Email)
TechSupportAPAC@hypertherm.com (Technical Service Email)

Hypertherm Europe B.V.

Vaartveld 9, 4704 SE
Roosendaal, Nederland
31 165 596907 Tel
31 165 596901 Fax
31 165 596908 Tel (Marketing)
31 (0) 165 596900 Tel (Technical Service)
00 800 4973 7843 Tel (Technical Service)
technicalservice.emea@hypertherm.com
(Technical Service Email)

Hypertherm (Shanghai) Trading Co., Ltd.

B301, 495 ShangZhong Road
Shanghai, 200231
PR China
86-21-80231122 Tel
86-21-80231120 Fax
86-21-80231128 Tel (Technical Service)
techsupport.china@hypertherm.com
(Technical Service Email)

South America & Central America: Hypertherm Brasil Ltda.

Rua Bras Cubas, 231 – Jardim Maia
Guarulhos, SP – Brasil
CEP 07115-030
55 11 2409 2636 Tel
tecnico.sa@hypertherm.com (Technical Service Email)

Hypertherm Korea Branch

#3904. APEC-ro 17. Heaundae-gu. Busan.
Korea 48060
82 (0)51 747 0358 Tel
82 (0)51 701 0358 Fax
Marketing.korea@hypertherm.com (Marketing Email)
TechSupportAPAC@hypertherm.com
(Technical Service Email)

Hypertherm Pty Limited

GPO Box 4836
Sydney NSW 2001, Australia
61 (0) 437 606 995 Tel
61 7 3219 9010 Fax
au.sales@Hypertherm.com (Main Office Email)
TechSupportAPAC@hypertherm.com
(Technical Service Email)

Hypertherm (India) Thermal Cutting Pvt. Ltd

A-18 / B-1 Extension,
Mohan Co-Operative Industrial Estate,
Mathura Road, New Delhi 110044, India
91-11-40521201/ 2/ 3 Tel
91-11 40521204 Fax
HTIndia.info@hypertherm.com (Main Office Email)
TechSupportAPAC@hypertherm.com
(Technical Service Email)

- Pump information 9**
- Warranty SC-11**
- Product stewardship SC-13**
- Environmental stewardship SC-17**
- Safety SC-19**
 - User qualification and trainingSC-20
 - Emergency medical information and treatmentSC-20
- Symbols and marks SC-21**
 - Information and hazard symbolsSC-21
 - Symbols and marks found on the data plate and the equipmentSC-22
- 1 Terminology 25**
- 2 Product description 29**
 - Pump exterior 30
 - Major systems 33
 - Electrical system 33
 - Hydraulic system 35
 - Low-pressure water system 39
 - High-pressure water system 40
- 3 Options 41**
- 4 Operation 43**
 - Safety 43
 - Overview 45
 - Inspect the equipment before operation 47
 - Turn on the pump 47
 - Operate the pump 49
 - Operate the pump remotely 66
 - Stop the pump 67
 - Emergency stop 67
 - Routine stop during operation 67
 - Turn off the pump at the end of the day 67

- 5 Preventive maintenance 69**
- Benefits of preventive maintenance 69
- Safety 70
- Preventive maintenance schedule 72
- Tools 74
- General 75
 - Examine the equipment for leaks or damage 75
- Electrical system 76
 - Make sure that the emergency stop button works 76
 - Examine cords and plugs for deterioration or damage 76
- Hydraulic system 77
 - Check the hydraulic fluid indicator 77
 - Check the hydraulic fluid level 78
 - Check the hydraulic fluid quality 80
 - Measure the hydraulic fluid temperature 81
 - Replace the hydraulic filter 83
 - Replace the hydraulic fluid, the hydraulic filter, the filler-breather cap, and the suction strainers 84
- Low-pressure water system 88
 - Check the low-pressure water pressure gauges 88
 - Measure the air pressure in the water accumulator tank 89
 - Replace the water filters 91
 - Test the low-pressure water TDS level 94
- High-pressure water system: Intensifier 96
 - Prepare to service the intensifier 97
 - Disassemble the intensifier 100
 - Repair the check valves and the low-pressure poppets 107
 - Repair the high-pressure cylinders 109
 - Assemble the intensifier 111
 - Intensifier parts 127
- High-pressure water system: Bleed-down valve 129
 - Examine the bleed-down valve for leaks or damage 129
 - Repair the bleed-down valve 130
 - Install the bleed-down valve 140
 - Bleed-down valve parts 143
- Start the pump after preventive maintenance 144
- Recycling and end of product life 146
- Preventive maintenance records 147

6 Parts lists 149

- Tools 150
- Preventive maintenance repair kits 151
- Other parts 153
- Complete list of preventive maintenance kits, parts, tools, and materials 156

7 Troubleshooting 157

- Safety 157
- Tips 157
- Alarm screens 158
- The pump will not start 158
- Intensifier 159
 - Stroking problems 159
 - Leaks 163
 - Short seal life 165
- Hydraulic fluid 166
 - Low pressure 166
 - High temperature 166
- Water pressure 168
 - No water pressure or low water pressure 168
 - Water pressure is too high 170
- Motor fault 171
- Noisy operation 171

8 Pump specifications 173

- All models 174
 - Hydraulic fluid 174
 - Operating conditions 174
 - Cooling requirements 174
- HyPrecision 50S 175
- HyPrecision 60S 177
- HyPrecision 75S 179
- Torque values 181
 - Fasteners 181
 - Fittings 182

- 9 Installation 185**
- Safety 185
- Buyer obligations 186
- Seller obligations 186
- Requirements 187
 - Location 187
 - Temperature 187
 - Electrical power 187
 - Water 188
- Receive and unpack the equipment 190
- Make the connections for remote operation 191
- Install the external air cooler 193
- Make the connections to the utility panel fittings 194
- Add hydraulic fluid 196
- Connect the electrical power 196
- Do the first startup 197
 - Do a preoperation inspection 197
 - Turn on the utilities 198
 - Change the system configuration on the operator interface 198
 - Start the pump 199

Model _____

Serial number _____

The serial number is on the data plate, which is found above the connection panel on the back of the pump.

System schematic drawing number _____

The system schematic drawing number is inside the electrical enclosure door on a green label and on the data plate.

Purchase date _____

Distributor _____

Installation date _____

Installed by _____

Notes

Waterjet product warranty coverage

Product	Warranty coverage up to:
HyPrecision pumps	27 months from the ship date, or 24 months from the date of proven installation, or 4,000 hours of operation, whichever occurs first
PowerDredge™ abrasive removal system	15 months from the ship date or 12 months from the date of proven installation, whichever occurs first
EcoSift™ abrasive recycling system	15 months from the ship date or 12 months from the date of proven installation, whichever occurs first
Bulk abrasive pots	15 months from the ship date or 12 months from the date of proven installation, whichever occurs first
Abrasive regulators	15 months from the ship date or 12 months from the date of proven installation, whichever occurs first
On/off valve air actuators	15 months from the ship date or 12 months from the date of proven installation, whichever occurs first
Diamond orifices	600 hours of operation with the use of a thimble filter and compliance with Hypertherm's water quality requirements

Consumable parts are not covered by this warranty. Consumable parts include, but are not limited to high-pressure water seals, check valves, cylinders, bleed-down valves, low-pressure seals, high-pressure tubing, and filters.

Hypertherm maintains a global regulatory management system to make sure that products comply with regulatory and environmental requirements.

National and local safety regulations

National and local safety regulations shall take precedence over instructions supplied with the product. The product shall be imported, installed, operated, and disposed of in compliance with national and local regulations applicable to the installation site.

Certification test marks

Certified products are identified by 1 or more certification test marks from accredited testing laboratories. The certification test marks are found on or near the data plate.

Each certification test mark means that the product and its safety-critical parts conform to the national safety standards as reviewed and determined by that testing laboratory. Hypertherm puts a certification test mark on its products only after that product is manufactured with safety-critical parts that have been approved by the accredited testing laboratory.

Once the product has left the Hypertherm factory, the certification test marks are invalid if any of these events occurs:

- The product is modified in a manner that creates a hazard or nonconformance with the applicable standards.
- Safety-critical parts are replaced with unapproved spare parts.
- Assembly is unauthorized.
- An accessory that uses or generates a hazardous voltage is added.
- There is tampering with a safety circuit or other feature that is designed into the product as part of the certification, or otherwise.

A Conformité Européene (CE) mark constitutes a manufacturer's declaration of conformity to applicable European directives and standards. Only those versions of Hypertherm products with a CE mark found on or near the data plate have been tested for compliance with the European Low Voltage Directive and the European Electromagnetic Compatibility Directive.

Product stewardship

Declaration of conformity

This Declaration of Conformity applies to these HyPrecision waterjet pump models based on testing of the HyPrecision™ 50S model:

HyPrecision 15	HyPrecision 50S	HyPrecision 100D
HyPrecision 30	HyPrecision 60S	HyPrecision 150D
HyPrecision 50	HyPrecision 75S	

Date of first fixing of Conformité Européene (CE) mark (Declaration of Conformity issued): 15 June 2010

Date of this Declaration of Conformity: 17 March 2014

This Declaration of Conformity was reissued because of a change to the product model name. No changes were made regarding safety.

Model units with a CE mark on the data plate meet the essential requirements of these European Union (EU) Directives using the applicable section of the EU standards and other normative documents.

- 97/23/EC Pressure Equipment Directive
- 2006/42/EC Machinery Directive
- 2006/95/EC Low Voltage Directive
- 2004/108/EC Electromagnetic Compatibility Directive

This declaration is not valid on units without a CE mark on the data plate.

For European customer inquiries, contact:

European Customer Service
Hypertherm Europe B.V.
Vaartveld 9
4704 SE
Roosendaal, Nederland
31 165 596907

To see the signed Declaration of Conformity in English:

1. Go to www.hypertherm.com.
2. Search for **documents library**.
3. Select **Waterjet Family** from the All dropdown list under Product/Product type.
4. Select **Regulatory** from the All Categories dropdown list.

These navigation instructions can change without notice.

Differences in national standards

Nations can apply different performance, safety, or other standards. National differences in standards include, but are not limited to:

- Voltages
- Plug and cord ratings
- Language requirements
- Electromagnetic compatibility requirements

These differences in national or other standards can make it impossible or impractical for all certification test marks to be put on the same version of a product. For example, the Canadian Standards Association (CSA) versions of Hypertherm's products do not comply with European electromagnetic compatibility requirements and therefore do not have a CE mark on the data plate.

Countries that require a CE mark or have compulsory electromagnetic compatibility regulations must use CE versions of Hypertherm products with the CE mark on the data plate. These may include, but are not limited to:

- Countries in the European Union
- Australia
- New Zealand
- Russia

It is important that the product and its certification test mark be suitable for the end-use installation site. When Hypertherm products are shipped to one country for export to a different country, the product must be configured and certified properly for the end-use installation site.

Higher-level systems

When an original equipment manufacturer (OEM) or a system integrator adds equipment such as cutting tables, motor drives, motion controllers, or robots to a Hypertherm waterjet cutting system, the combined system is considered a higher-level system. A higher-level system with hazardous moving parts can constitute industrial machinery or robotic equipment, in which case the OEM, system integrator, or end-use customer can be subject to more regulations and standards than those applicable to the waterjet cutting system manufactured by Hypertherm.

It is the responsibility of the end-use customer and the OEM or system integrator to do a risk assessment for the higher-level system and to provide protection against hazardous moving parts. Unless the higher-level system is certified when the OEM or system integrator incorporates Hypertherm products into it, the installation can be subject to approval by local authorities. Seek advice from legal counsel and local regulatory experts if you are uncertain about compliance.

External interconnecting cables between parts of the higher-level system must be suitable for exposure to contaminants and movement as required by the final end-use installation site. When the external interconnecting cables are subject to exposure to oil, dust, water, or other contaminants, hard usage ratings can be required. When external interconnecting cables are subject to continuous movement, constant flexing ratings can be required. It is the responsibility of the OEM, system integrator, or end-use customer to make sure that external interconnecting cables are suitable for the application and comply with all federal, state, and local regulations.

Proper disposal of Hypertherm products

Hypertherm waterjet cutting equipment, like all products with electronics, can contain materials or parts, such as printed circuit boards, that can not be discarded with ordinary waste. It is your responsibility to dispose of Hypertherm product or part in an environmentally suitable manner and in compliance with national and local codes.

In the United States, check all federal, state, and local laws. In the European Union (EU), check the EU directives, national, and local laws. In other countries, check national and local laws. Consult with legal or other compliance experts when applicable. For more information, go to www.hypertherm.com/customer-support/product-service/recycling.

Proper handling and safe use of chemicals

Material safety data sheets (MSDS) and safety data sheets (SDS) are part of a hazard communication plan that supplies detailed information about hazardous chemicals. The information includes the chemical's toxicity and reactivity, first aid for exposure, approved storage and disposal, recommended protective equipment, and spill-handling procedures.

The Occupational Safety and Health Administration (OSHA) has presented new hazardous chemical labeling requirements as a part of its recent revision of the Hazard Communication Standard (29 CFR 1910.1200), to align with the United Nations' Globally Harmonized System of Classification and Labelling of Chemicals (GHS). The GHS is an international system for standardizing chemical classification and labeling.

Chemical regulations in the USA, Europe, and other locations require that Material Safety Data Sheets (MSDS) and Safety Data Sheets (SDS) be made available for chemicals that are supplied with the product and chemicals used in or on the product. This list of chemicals is supplied by Hypertherm.

To see MSDS and SDS:

1. Go to www.hypertherm.com.
2. Search for **documents library**.
3. Select **Waterjet Family** from the All dropdown list under Product/Product type.
4. Select **Material Safety Data Sheets** from the All Categories dropdown list.

These navigation instructions can change without notice.

Environmental stewardship

Particle emission and wastewater quality

Hypertherm does not manufacture or supply the materials that are cut and has no knowledge whether the particles released from materials that are cut will pose a physical hazard or health risk. Please consult with your supplier or other technical advisor if you need guidance concerning the properties of the material you will cut using a Hypertherm product.

If you are not fully aware of and up to date on all applicable government regulations and legal standards for the installation site, consult a local expert before purchasing, installing, and operating the equipment.

The end user is responsible for the safe operation of this equipment.

 WARNING	<p>Before operating any Hypertherm equipment, read the safety instructions in your product's manual. Failure to follow safety instructions can result in personal injury or in damage to equipment.</p>
---	---

Copies of the manuals may accompany the product in electronic and printed formats. You can also see copies of the manuals online, in all languages available for each manual.

1. Go to www.hypertherm.com.
2. Search for **documents library**.
3. Select **Waterjet Family** from the All dropdown list under Product/Product type.
4. Select **Manuals/Service Information** from the All Categories dropdown list. It is optional to select a manual type from the All subcategories dropdown list.

These navigation instructions can change without notice.

The safety precautions in this manual are general and can not anticipate every situation. Hypertherm Inc. acknowledges that unforeseen situations such as equipment failure, site variability, insufficient maintenance, failure of control equipment, and other events can cause equipment damage, injuries, or death. It is the user's responsibility to identify hazards and to take the steps necessary to minimize risks.

Keep these instructions near the equipment. This manual is intended to familiarize the user with the equipment and its parts, safe operation, and maintenance.

All people who operate or are exposed to this equipment must know this information:

- Applicable safety standards
- The use, limitations, and care of personal protective equipment
- The location of the written hazard communication program and safety data sheets
- How to recognize hazardous energy sources
- The correct methods for isolating and controlling energy, including lock out–tag out procedures

 DANGER	<p>A person who works on deenergized machinery can be seriously injured or killed if the machinery is reenergized without permission.</p> <p>All workers must respect lock out–tag out devices.</p> <p>All workers in an area where energy-control procedures are used must receive training regarding the energy-control procedure and the prohibition against removing a lock-out or a tag-out device.</p>
--	--

Safety

User qualification and training

All users must read and understand these instructions before installing, operating, or doing maintenance on this equipment.

Do not permit an untrained person to operate this equipment. Operators must be qualified to operate and maintain this equipment. Training should include this information:

- How to start and stop the equipment during routine operation and in an emergency situation
- The conditions and actions that can lead to injuries to people and damage to the equipment
- How to operate all controls
- How to identify and respond to a problem with the equipment
- How to do maintenance procedures
- A copy of the operator manual

This list is not all-inclusive.

Emergency medical information and treatment

The use of high-pressure equipment exposes the operator and other people in the area to high-pressure water. Potential harms include eye injuries, lacerations, infections, and amputations. Do not put ice or heat on a waterjet injury. Support injured limbs and extremities above heart level if possible.

A high-pressure injection injury is a surgical emergency. Seek immediate medical treatment for all high-pressure waterjet injuries. Delayed treatment can cause serious injuries or death.

Waterjet operators should carry a waterproof emergency medical tag or card that describes the nature of high-pressure waterjet injuries and the recommended treatment. Show the tag or card to emergency responders and medical professionals.











This card can be copied, cut out, laminated, and folded.

 <p style="text-align: center;">MEDICAL INFORMATION</p> <hr/> <p>A high-pressure injection injury is a surgical emergency.</p> <p>Seek immediate medical treatment for all high-pressure waterjet injuries.</p> <p>Delayed treatment can cause serious injuries or death.</p>	<p>The person carrying this card has been exposed to a waterjet of up to 4,137 bar (60,000 psi) and a velocity of 609 m/s (2,000 feet/second). The waterjet can contain abrasive materials.</p> <p>Skin can appear intact or show a minor pinhole-sized puncture wound. The injured area can become swollen, painful, and pale over the next 4 to 6 hours. Tissue becomes ischemic and necrotic within 12 hours.</p> <p>Consult a surgical specialist immediately for decompression, removal of foreign materials, and debridement.</p> <p>Administer broad-spectrum, intravenous antibiotics for Gram-negative and Gram-positive organisms.</p> <p>X-ray is the imaging of choice.</p> <p>Acute compartment syndrome is possible. Leave the wound open.</p>	<p>Do not use solvents other than isotonic sodium chloride solution for irrigating the wound.</p> <p>Do not use digital or local nerve blocks. Give analgesics by mouth or injection.</p>
--	---	---









Information and hazard symbols

 WARNING	<p>Before operating any Hypertherm equipment, read the safety instructions in your product's manual. Failure to follow safety instructions can result in personal injury or in damage to equipment.</p>
---	---

Some symbols in this table can apply to other products.

 DANGER	<p>This symbol identifies an imminently hazardous situation, which, if not avoided, will cause serious injuries or death.</p>
 DANGER	<p>Dangerous voltage To reduce the risk of serious injuries or death, wear approved protection and follow safety recommendations when working with electricity.</p>
 WARNING	<p>This symbol identifies a potentially hazardous situation, which, if not avoided, can cause serious injuries or death.</p>
 WARNING	
 WARNING	<p>A waterjet is a cutting tool. A high-pressure injection injury is a surgical emergency. Seek immediate medical treatment for all high-pressure waterjet injuries. Delayed treatment can cause serious injuries or death.</p>
 WARNING	<p>Do not touch a hot surface.</p>
 WARNING	<p>Do not operate this equipment without the guard installed.</p>
 WARNING	<p>Risk of explosion</p>
 CAUTION	<p>This symbol identifies a potentially hazardous situation, which, if not avoided, can cause minor or moderate injuries or property damage.</p>
 CAUTION	
	<p>High-pressure water can cause eye injuries. Wear approved eye protection when operating or working near this equipment.</p>

Symbols and marks













	Prolonged exposure to noise can cause permanent hearing loss. Wear approved ear protection and control exposure time when operating or working near this equipment.
	High-pressure water can cause severe cuts or lacerations, abrasions, and punctures. Wear approved hand protection when operating or working near this equipment. Precision parts have sharp corners or edges. Wear protective gloves when handling parts.
	Some materials produce airborne contaminants or suspended particles when cut. Wear approved respiratory protection.
	Refer to the instruction manual. Read and understand all of the safety guidelines in this manual.
	This symbol identifies a mandatory action.
	This symbol identifies a prohibited action.
	This symbol identifies tools or materials that are required or recommended for a procedure.
	This symbol identifies a note or helpful information.

Symbols and marks found on the data plate and the equipment

Some symbols or marks in this table can apply to other products.

	Correct direction of motor rotation (motor rotation arrow)
S/N	Serial number
V	Volts
Φ	Number of phases in a power system
Hz	Frequency (hertz)
FLA	Full-load current (amperage)
SCCR	Short-circuit current rating
IP	Ingress protection rating
Ⓜ I_{max}	Primary motor maximum current draw (amperes)
Ⓜ kW	Primary motor power output (kilowatts)
l/min	Maximum outlet flow rate (liters/minute)
MPa	Maximum outlet water pressure (megapascals)
DWG	System schematic drawing number

Symbols and marks

	<p>The Conformité Européene (CE) mark shows that a product complies with standards to the product to which the mark is affixed.</p> <p>The CE mark signifies the manufacturer's declaration of conformity to applicable European directives and standards. Only those versions of products with a CE mark found on or near the data plate have been tested for compliance with the European Low Voltage Directive, the European Electromagnetic Compatibility Directive, the Pressure Equipment Directive, and the Machinery Directive.</p>
	<p>Identifies the terminal of a protective earth (ground) electrode or a terminal intended to connect to an external conductor for protection against electric shock in case of a fault</p>
 <p>AIR IN</p>	<p>Compressed air that operates the bleed-down valve</p>
 <p>COOLING IN</p>	<p>Water-cooled system: Low-pressure supply water or water from a chiller that goes to a heat exchanger Air-cooled system: Hydraulic fluid that is returning from an external air cooler</p>
 <p>COOLING OUT</p>	<p>Water-cooled system: Low-pressure water from the heat exchanger that goes to a drain or returns to a chiller Air-cooled system: Hydraulic fluid that is sent to an external air cooler</p>
 <p>CUTTING WATER IN</p>	<p>Low-pressure water from a water softener, a reverse osmosis system, a well, or a public utility</p>
 <p>CUTTING WATER OUT</p>	<p>Water that has been pressurized by the intensifier for piercing or cutting</p>
 <p>WASTEWATER OUT</p>	<p>Water from the bleed-down valve and the low-pressure system to a drain</p>
	<p>Prefilter water pressure</p>
	<p>Postfilter water pressure</p>
	<p>Cut pressure</p>
	<p>Pierce pressure</p>
	<p>Hydraulic pressure (for single- or redundant-intensifier pumps)</p>

Section 1

Terminology

Some terms could apply to other products.

attenuator

A pressure vessel that compensates for pressure fluctuations and maintains a consistent output water pressure

AWG

American Wire Gauge (AWG), a standardized wire gauge system used in North America

bar

A unit of pressure: 1 bar equals 100 kPa or 14.5 psi or 100,000 N/m²

CNC

A computer numerical control (CNC) controls the motion of a machine tool

COOLING IN

Water-cooled system: Low-pressure supply water or water from a chiller that goes to a heat exchanger

Air-cooled system: Hydraulic fluid that is returning from an external air cooler

cooling mode

The pump runs with the intensifier disabled. Hydraulic fluid circulates through the pump at minimum pressure, the cutting-water solenoid is open, and the boost pump is on.

COOLING OUT

Water-cooled system: Low-pressure water from the heat exchanger that goes to a drain or returns to a chiller

Air-cooled system: Hydraulic fluid that is sent to an external air cooler

cooling water

Low-pressure water that circulates through the heat exchanger in water-cooled systems to cool the hydraulic fluid, refer to **COOLING IN** and **COOLING OUT**

1 – Terminology

cSt

A centistoke (cSt) is a measurement of kinematic viscosity. Water has a viscosity of 1 centistoke or 1 mm²/second.

cut-pressure mode

High-pressure water from the intensifier that is at cutting pressure. Refer to **piece-pressure mode**.

CUTTING WATER IN (low-pressure water)

Low-pressure water from a water softener, a reverse osmosis system, a well, or a public utility, that is between the utility panel and the intensifier (refer to **prefilter water** and **postfilter water**)

CUTTING WATER OUT (high-pressure water)

Water that has been pressurized by the intensifier for piercing or cutting

dB(A)

A-weighted decibels (dB(A)) is an expression of the relative loudness of sounds in air as perceived by the human ear

dynamic seal

The high-pressure seal in the high-pressure cylinder that is nearest to the hydraulic center section. This seal is in direct contact with the plunger (refer to **static seal**).

energy-isolating device

A mechanical device that physically prevents the transmission or release of energy, including but not limited to the following: a manually operated electrical circuit breaker, a disconnect switch, a manually operated switch by which the conductors of a circuit can be disconnected from all ungrounded supply conductors, a line valve, and any similar device used to block or isolate energy. Push buttons (like the **EMERGENCY STOP** button), selector switches, and other control circuit-type devices are not energy-isolating devices.

energy source

Any source of electrical, mechanical, hydraulic, pneumatic, chemical, thermal, or other energy

fitting

A coupling, valve, or gauge that stops, regulates, or directs the flow of water in a pipe

hard water

Water with dissolved minerals in it, typically calcium and magnesium

high-pressure water (CUTTING WATER OUT)

Water that has been pressurized by the intensifier for piercing or cutting

hose

A flexible hollow cylinder. Dimensions are based on the inside diameter (ID).

inrush current

The maximum instantaneous current that a motor draws when it is first turned on, also called input surge current or switch-on surge

ISO

The International Organization for Standardization (ISO), an independent membership organization that develops voluntary standards

1 – Terminology

JIC

Joint Industry Council (JIC) fittings, a type of flare fitting used in fluid delivery applications. These fittings are machined with a 37° flared seating surface and are composed of a fitting, a flare nut, and a sleeve.

kPa

A kilopascal (kPa) is a unit of pressure: 1 kPa equals 0.01 bar or 0.15 psi or 1,000 N/m²

lap

To rub a stainless steel surface against lapping paper to make the surface very smooth and flat

lock out tag out

Lock out tag out refers to specific practices and procedures that protect workers from the unexpected energization or start up of machinery and equipment, or the release of hazardous energy during maintenance or repair activities. Lock-out devices hold energy-isolation devices in a safe or “off” position and can not be removed without a key or other unlocking mechanism, or through extraordinary means, such as bolt cutters. Tag-out devices are prominent warning devices that an instructed person fastens to energy-isolating devices to warn others not to reenergize the machine. Tags do not provide the physical restraint of a lock.

low-pressure water (CUTTING WATER IN)

Low-pressure water from a water softener, a reverse osmosis system, a well, or a public utility, that is between the utility panel and the intensifier (refer to **prefilter water** and **postfilter water**)

NPT

National pipe thread taper (NPT), a common United States standard for tapered threads that are used on fittings and pipes

OEM

An original equipment manufacturer (OEM) of machines that are sold directly to end users

overstroke (fault)

An overstroke fault occurs when the hydraulic piston travels faster in 1 or both directions than the output water flow of the waterjet pump can support

pierce-pressure mode

Water from the intensifier that is used to pierce the material to be cut. Using a reduced pressure prevents brittle materials from cracking. Refer to **cut-pressure mode**.

pipe

A rigid tube that carries low-pressure fluid

postfilter water

Low-pressure water that is between the filters and the intensifier

prefilter water

Low-pressure water that is between the utility panel and the water filters

psi

Pound-force per square inch (PSI) is a unit of pressure: 1 psi equals 0.07 bar or 6.89 kPa or 6,895 N/m²

reverse osmosis

A method for treating water by forcing it through a semipermeable membrane to remove impurities that can damage high-pressure parts

1 – Terminology

SAE

SAE International is a professional association of engineers and technical experts that coordinates the development of technical standards based on best practices in the aerospace, commercial vehicle, and automotive engineering. SAE Code 61 fittings are designed for 207-bar or 20,684-kPa (3000-psi) applications. SAE Code 62 fittings are designed for 414-bar or 41,369-kPa (6,000-psi) applications.

static seal

The high-pressure seal at the output end of the high-pressure cylinder. This seal does not touch the plunger (refer to **dynamic seal**).

supply water

Water going to the pump from a water softener, a reverse osmosis system, a well, or a public utility that is typically delivered to a location through a system of pumps and pipes

system integrator

An integrator of waterjet cutting systems that are sold directly to end users

tubing

A rigid tube that carries high-pressure fluid

valve

A device used to control the rate of flow in a pipe or a tube

WASTEWATER OUT

Water from the bleed-down valve or the low-pressure system that goes to a drain

weep hole

A small hole that is drilled into high-pressure fittings to let leaking water escape

Section 2

Product description

HyPrecision pumps use a hydraulic system to pressurize water for waterjet cutting. Four systems make up the pump: hydraulic, low-pressure water, high-pressure water, and electrical. These systems are not independent of each other.

Color is used throughout the manual to identify the different systems.



In the **Preventive maintenance** section, which begins on page 69, color is used to highlight referenced parts.

Pump exterior

Gauge panel



Prefilter water-pressure gauge

The prefilter water-pressure gauge shows the water pressure before the water goes through the filters. The usual operating range is 2.76 bar to 7.58 bar or 275.79 kPa to 758.42 kPa (40 psi to 110 psi).



Postfilter water-pressure gauge

The postfilter water-pressure gauge shows the water pressure after the water goes through the filters. The usual operating range is 2.76 bar to 7.58 bar or 275.79 kPa to 758.42 kPa (40 psi to 110 psi).



Hydraulic pressure gauge

This gauge shows the hydraulic pressure in the pump.



Cut-pressure control knob

This knob changes the water pressure from the intensifier for cutting.

To calculate the approximate water pressure, multiply the hydraulic pressure gauge value by 20.

	Hydraulic pressure		Water pressure
	210 bar	× 20 =	4,200 bar
Example:	20,650 kPa	× 20 =	41,300 kPa
	3,000 psi	× 20 =	60,000 psi



Pierce-pressure control knob

This knob changes the water pressure from the intensifier for piercing.

2 – Product description

Utility panel

These fittings are found on the utility panel on the rear of the pump.

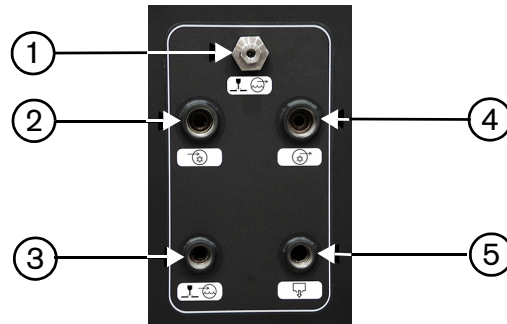

- 1 CUTTING WATER OUT
- 2 COOLING IN
- 3 CUTTING WATER IN

- 4 COOLING OUT
- 5 WASTEWATER OUT



CUTTING WATER OUT

This water has been pressurized by the intensifier for piercing or cutting. Water goes from the pump to the waterjet cutting table.



COOLING IN

Water-cooled system

This is low-pressure supply water or water from a chiller that goes to a heat exchanger.

Air-cooled system

This is hydraulic fluid that is returning from an external air cooler.



CUTTING WATER IN

This low-pressure water goes into the pump from a water softener, a reverse osmosis system, a well, or a public utility.



COOLING OUT

Water-cooled system

This is low-pressure water from a heat exchanger that goes to a drain or returns to a chiller.

Air-cooled system

This is hydraulic fluid that is sent to an external air cooler.



WASTEWATER OUT

This line carries water from the bleed-down valve and the low-pressure system to a drain.

2 – Product description

This diagram shows the flow of water and hydraulic fluid through the pump system.

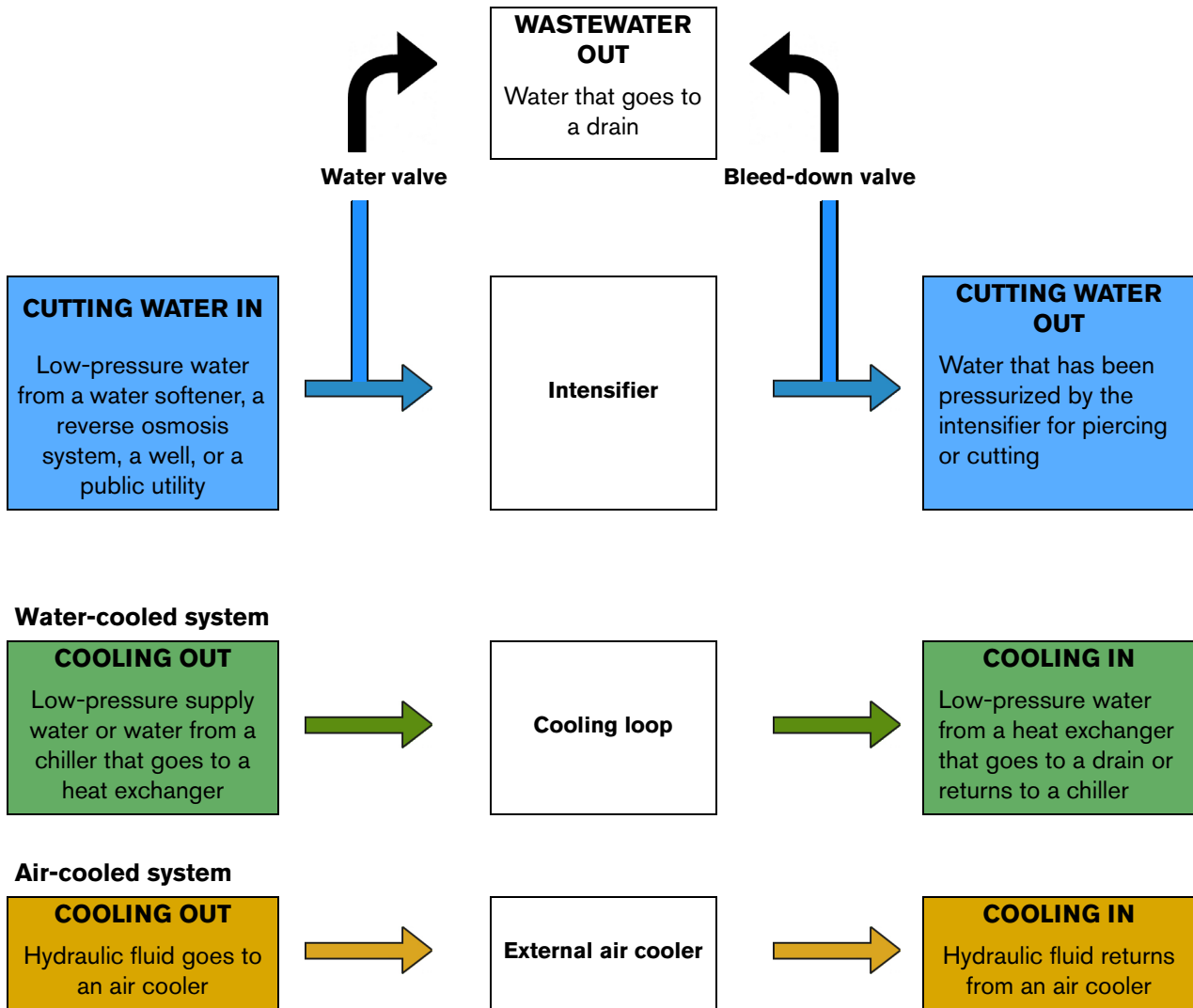

Major systems

Electrical system

The pump uses 3-phase alternating current (AC) electricity. Some parts, such as valve solenoids and sensors, use 24-volt direct current (VDC) electricity from a power supply in the electrical enclosure.

End-of-travel sensing

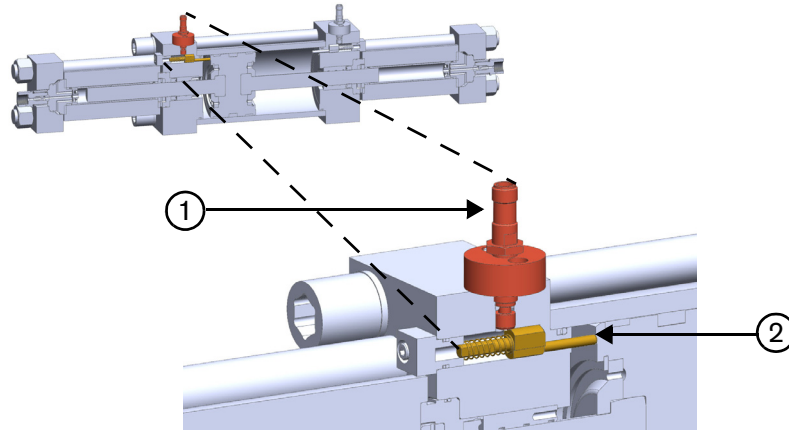

1 Proximity sensor

2 Indicator pin

When hydraulic fluid forces the piston to the end of the hydraulic center section, the piston pushes against a spring-loaded indicator pin. A signal from the proximity sensor above the indicator pin causes the shift valve in the primary hydraulic manifold to change the direction of the intensifier.

Primary motor

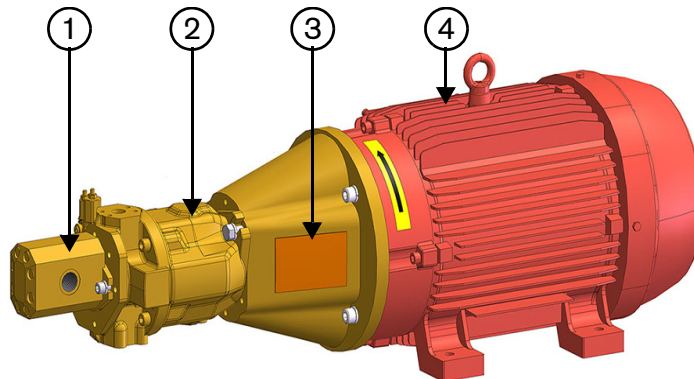

1 Gear pump

2 Primary hydraulic pump

3 Shaft access cover

4 Primary motor

The primary motor drives the primary hydraulic pump that moves hydraulic fluid through the intensifier. A gear pump moves hydraulic fluid through the cooling loop.

2 – Product description

Electrical enclosure

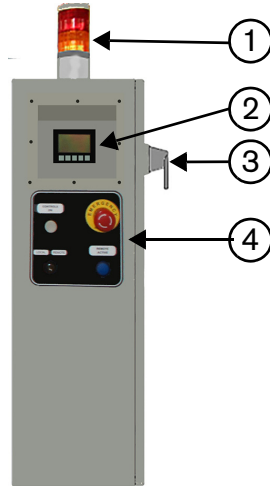

1 Stack light

2 Operator interface

3 Primary breaker disconnect lever

4 Operation panel

Status indicators, pump control parts, and the primary breaker disconnect lever are on the outside of the electrical enclosure. The motor starter, the thermal overload relay, and the breakers are inside the enclosure.

The stack light illuminates when the system detects a warning or fault condition.

The operator interface is a controller for the pump and the intensifier. A series of screens shows equipment status and permits the operator to operate the pump and the intensifier. The primary screen shows information about warnings and faults.

The primary breaker disconnect lever disconnects electricity to the pump motor and controls.

The operation panel turns the control circuit inside the pump on and off and controls local and remote pump operation.

Motor starter

HyPrecision 50S, 60S, and 75S pumps use a soft starter to gradually increase the output of the electric motor. The only maintenance required for the soft starter is to make sure that the fan vents are clean.

Micro SD card

A micro SD card inside the enclosure is used to load updates to the control software or to back up the program.

2 – Product description

Hydraulic system

The primary motor runs the primary hydraulic pump, which pressurizes fluid from the hydraulic fluid tank. The pressurized hydraulic fluid passes through the primary hydraulic manifold, which contains a shift valve that delivers hydraulic fluid to alternating sides of the intensifier.

Low-pressure supply water enters the high-pressure cylinder in the intensifier, where the piston compresses the water to make high-pressure water for piercing or cutting.

Hydraulic fluid from the hydraulic center section in the intensifier returns to the hydraulic fluid tank through the primary hydraulic manifold.

The cooling loop keeps the hydraulic fluid at its optimum temperature. A gear pump moves hydraulic fluid from the hydraulic fluid tank and sends it through a heat exchanger, where heat transfers through fins to cooling water or to an optional fan. The hydraulic fluid passes through a hydraulic filter and then returns to the hydraulic fluid tank.

Hydraulic fluid tank

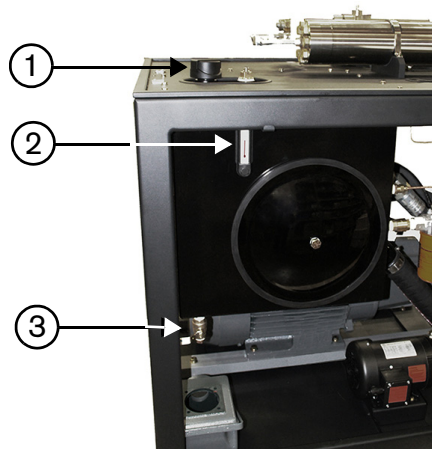

- 1 Filler-breather cap
- 2 Sight gauge

- 3 Drain valve

A filler-breather cap keeps the contents of the tank free of airborne contaminants and permits access to the tank for adding hydraulic fluid. A temperature sensor and a level sensor monitor the hydraulic fluid. A sight gauge permits observation of the hydraulic fluid level and quality. Suction strainers prevent contaminants from entering the primary pump and the gear pump.

2 – Product description

Primary hydraulic manifold

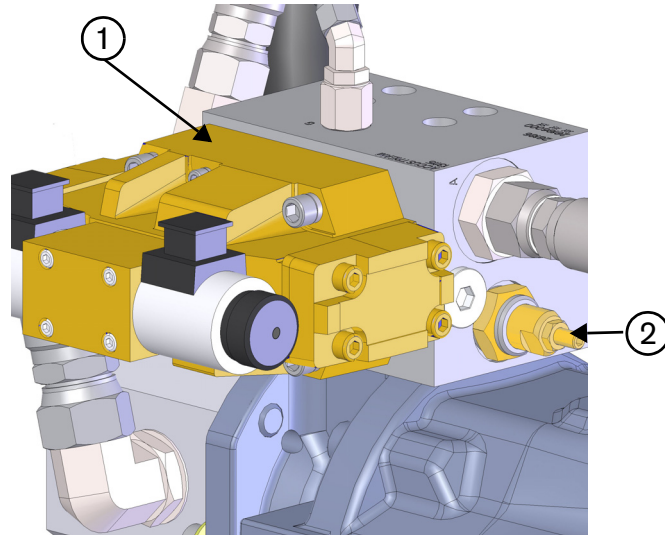

1 Shift valve

2 Relief valve

A shift valve mounted on the manifold directs the flow of pressurized hydraulic fluid to alternating sides of the intensifier. A relief valve protects the pump from too much pressure.

Intensifier

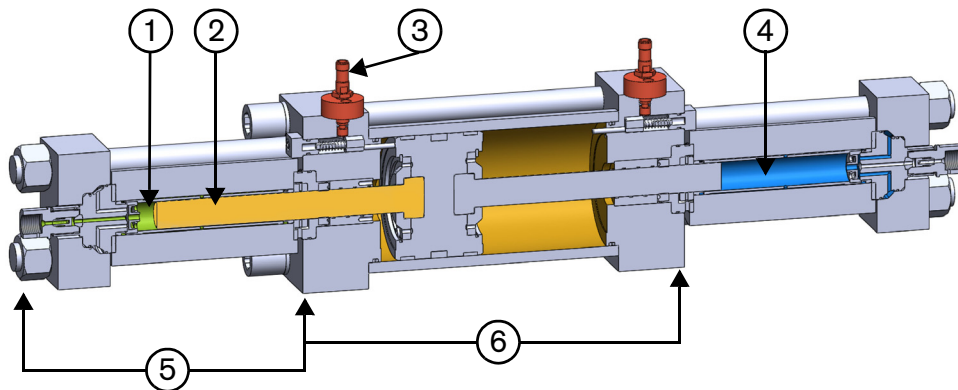

1 High-pressure water

2 Plunger

3 Proximity switch

4 Low-pressure water

5 High-pressure end

6 Hydraulic center section

A proximity switch at each end of the hydraulic center section signals the shift valve.

Ceramic plungers connected to each side of the piston extend into the left and right high-pressure ends. Hydraulic fluid pushes the piston to 1 side while low-pressure supply water fills the empty cylinder. The plunger on the opposite side of the cylinder compresses the water for piercing or cutting.

2 – Product description

Hydraulic control manifold

Standard pumps are equipped with a hydraulic control manifold.

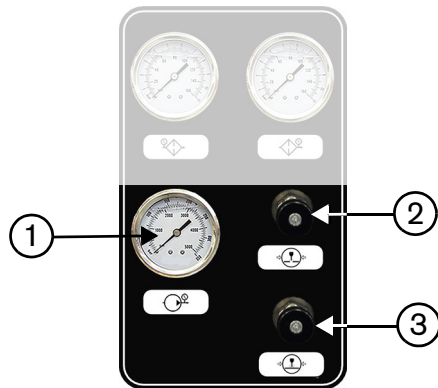

Front

- 1 Hydraulic pressure gauge
- 2 Cut-pressure control knob
- 3 Pierce-pressure control knob

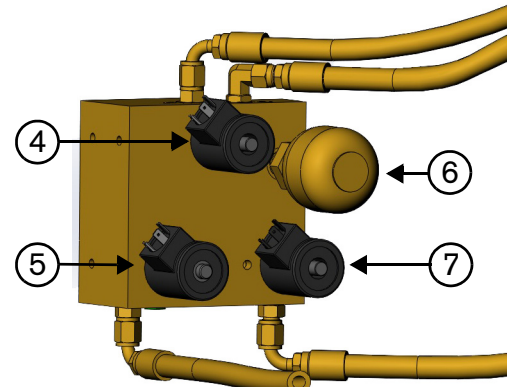

Rear

- 4 Pressure-enable solenoid
- 5 Cut-pressure solenoid
- 6 Hydraulic accumulator
- 7 Bleed-down valve solenoid

Hydraulic pressure gauge

This gauge shows the hydraulic pressure in the pump.

Cut-pressure control knob

This knob changes the water pressure from the intensifier for cutting.

To calculate the approximate water pressure, multiply the hydraulic pressure gauge value by 20.

Pierce-pressure control knob

This knob changes the water pressure from the intensifier for piercing.

Pressure-enable solenoid

This solenoid turns the pump pressure on and off.

Cut-pressure solenoid

This solenoid puts the pump in pierce pressure mode when it is on and cut-pressure mode when it is off.

Hydraulic accumulator

This equalizes hydraulic fluid pressure for the hydraulic gauge.

Bleed-down valve solenoid

This solenoid opens and closes the bleed-down valve.

2 – Product description

Pressure compensator

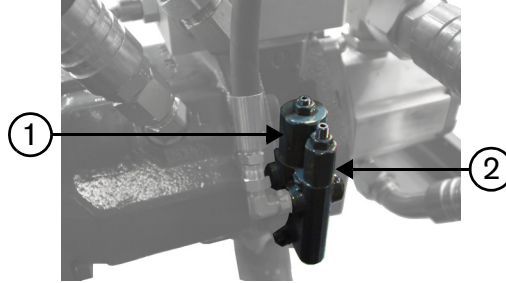

1 Compensating valve

2 Differential pressure valve

The pressure compensator controls water pressure by limiting the minimum and maximum hydraulic fluid pressure to the intensifier.

The compensating valve limits the maximum pump pressure. The differential pressure valve limits the minimum hydraulic pressure.

Cooling loop

Compressing hydraulic fluid generates substantial heat that can damage equipment and decrease the life of the fluid. The cooling loop keeps the hydraulic fluid at its optimum temperature. The heat exchanger, gear pump, hydraulic fluid, filter, and low-pressure cooling water or an external air cooler make up a cooling loop.

Water-cooled heat exchanger (standard)

When the primary motor is running, low-pressure supply water or water from a chiller circulates through a heat exchanger. Water from the heat exchanger goes to a drain or returns to the chiller.

A water-modulating valve is standard in systems without a chiller. This valve adjusts the flow rate of water based on the temperature of the hydraulic fluid.

External air cooler (optional)

The gear pump directs hydraulic fluid to an external air cooler, which uses a fan to cool the fluid.

When the hydraulic fluid temperature in the tank is higher than 55°C (130°F), a fan forces ambient air over cooling fins to cool the hydraulic fluid. The fan runs for at least 10 minutes. If the hydraulic fluid temperature is lower than 45°C (113°F) after 10 minutes, the fan turns off. If the hydraulic fluid temperature is higher than 45°C (113°F) after 10 minutes, the fan continues running.

Hydraulic fluid from the air cooler goes through a filter and then returns to the hydraulic fluid tank.

Low-pressure water system

The low-pressure water system includes the supply water. In water-cooled systems it also includes a cooling water loop and a heat exchanger.

Low-pressure water

Water coming in to the pump (CUTTING WATER IN) flows through a 1-way check valve into the boost pump to increase water pressure. From the boost pump, the water passes through 3 filters to remove contaminants. Water pressure gauges show the pressure before and after water goes through the filters. A switch after the filters tells the controller if the water pressure is higher than the minimum required. Filtered water collects in the accumulator tank, which equalizes the water pressure. The water enters the high-pressure ends in the intensifier, which compresses the water to make high-pressure water for piercing or cutting (CUTTING WATER OUT).

Boost pump

Because supply water is usually at a low pressure, a boost pump is used to increase the water pressure to 7.85 bar or 758.42 kPa (110 psi). A sustained pressure of less than 2.76 bar or 275.79 kPa (40 psi) causes the pump to turn off.

The boost pump assembly includes a pump, a 1-way check valve, and a bypass relief valve that affect the water pressure coming from the boost pump.

The operator interface protects the boost pump from overheating by turning the boost pump ON only when cutting water is needed and when the water pressure is less than the low-pressure switch setpoint.

The boost pump motor starter has an integrated starter and a thermal overload device. The overload setting is set at the factory and should not require adjustment.

Cooling water (for water-cooled systems)

When the primary motor is running, low-pressure supply water or water from a chiller circulates through a heat exchanger. Water from the heat exchanger goes to a drain or returns to the chiller.

The water-modulating valve adjusts the cooling water flow rate automatically to control the temperature of the hydraulic fluid.

High-pressure water system

Intensifier

Ceramic plungers connected to each side of the piston extend into the left and right high-pressure cylinders. Hydraulic fluid pushes the piston to 1 side while low-pressure supply water fills the empty cylinder. The plunger on the opposite side of the cylinder compresses the water for piercing or cutting.

The plungers in the intensifier compress water up to 4,136.85 bar or 413,685 kPa (60,000 psi). This pressurized water exits the high-pressure end through a check valve and goes to the attenuator.

Attenuator

The piston stroking causes a brief change of water pressure in the high-pressure ends. The attenuator compensates for pressure fluctuations and maintains a consistent output water pressure.

Pumps with a 2-liter attenuator have an attenuator guard, which is supplied for safety.

Bleed-down valve

The bleed-down valve is a normally open, hydraulic-actuated dump valve. When the pump is turned off or it is changed from cut-pressure mode to pierce-pressure mode, the valve opens to discharge water from the system.

High-pressure water

This water has been pressurized by the intensifier for piercing or cutting. It is also called **CUTTING WATER OUT**.

HyPrecision 50S, 60S, and 75S pumps are available with these optional features.

Voltage

Refer to the data plate or the system schematic drawing for the voltage of the pump.

50 Hz	60 Hz
400 V	460 V or 208 V to 230 V (50 hp only)

External air cooler

Standard pumps are equipped with a water-cooled heat exchanger. In an air-cooled system, the temperature sensor in the hydraulic fluid tank turns on an external air-cooled fan.

Proportional control valve

The proportional control valve electronically varies back pressure to the pump compensator. The pump runs at maximum hydraulic pressure when the valve is completely closed.

Redundant intensifier

A second intensifier reduces downtime by permitting the operator to use one or the other.











Both intensifiers cannot run at the same time on this pump model.







Section 4

Operation

Safety

	Refer to the instruction manual. Read and understand all of the safety guidelines in this manual.
 DANGER	Do not stand in line with any high-pressure fitting while the equipment is running. A sudden discharge of water can cause serious injuries or death.
 WARNING	A waterjet is a cutting tool. A high-pressure injection injury is a surgical emergency. Seek immediate medical treatment for all high-pressure waterjet injuries. Delayed treatment can cause serious injuries or death.
 WARNING	Do not operate the pump without the shaft access cover and all other safety devices correctly installed. Do not remove guards while the pump is operating.
 WARNING	Do not operate this equipment without the guard installed.
 WARNING	Risk of explosion
 WARNING	Personal protective equipment is recommended. Failure to wear personal protective equipment can cause injuries or death.
 WARNING	Do not touch a hot surface. Fittings can get hot, especially when they are not tightened properly.
 CAUTION	If a water line, fitting, or valve might be frozen, do not operate the pump. Thaw the equipment until water moves freely through the entire water circuit.

4 – Operation

	High-pressure water can cause eye injuries. Wear approved eye protection when operating or working near this equipment.
	This waterjet equipment might exceed national and local codes for permitted noise levels. When this pump is running, the noise level is 75 dB(A) to 80 dB(A). Noise level is related to factors such as water flow rate, pipe layout, and the acoustical characteristics of the building. Prolonged exposure to noise can cause permanent hearing loss. Wear approved ear protection and control exposure time when operating or working near this equipment.
	High-pressure water can cause severe cuts or lacerations, abrasions, and punctures. Wear approved hand protection when operating or working near this equipment.
	Some materials produce airborne contaminants or suspended particles when cut. Wear approved respiratory protection.
	Examine and clean the equipment regularly. Make repairs immediately.
	Keep the work area clean and free of fluid spills.

Hypertherm products are designed and manufactured with a commitment to continuous quality control and safety. Contact a Hypertherm Technical Service Associate for information and support regarding the installation, operation, maintenance, and repair of this equipment.

Overview

Electrical enclosure

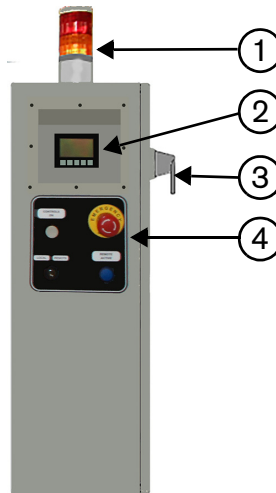

- | | | | |
|---|--------------------|---|----------------------------------|
| 1 | Stack light | 3 | Primary breaker disconnect lever |
| 2 | Operator interface | 4 | Operation panel |

Pump controls, status indicators, and the primary breaker disconnect lever are on the outside of the electrical enclosure.

Stack light

The stack light illuminates when the system detects a warning or fault condition. An amber stack light blinks to signal a condition that requires attention. A red stack light blinks to show that a fault has occurred.

Operator interface

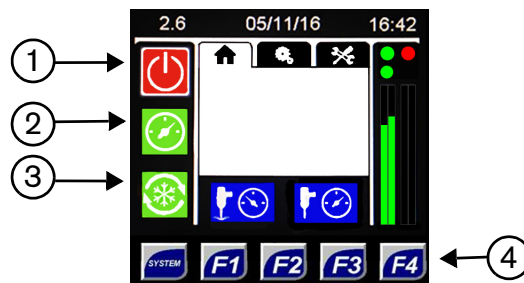

- | | | | |
|---|-----------------|---|---------------|
| 1 | Pump off | 4 | Function keys |
| 2 | Pump on | | |
| 3 | Cooling mode on | | |

The operator interface is a controller for the pump and the intensifier. A series of screens shows equipment status and permits the operator to operate the pump and the intensifier.

 The operator interface is the standard controller for this pump. Some original equipment manufacturers (OEMs) or system integrators might change the controller. In these cases, refer to the documentation provided by the OEM or system integrator for operation instructions.

4 – Operation

Operation panel

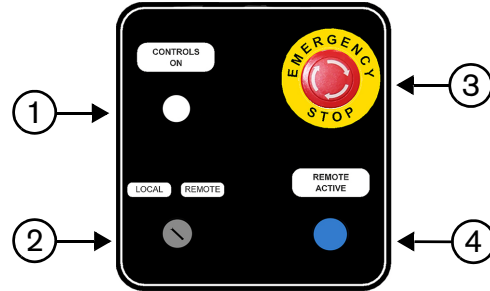

- | | | | |
|---|-------------------------|---|-------------------------------|
| 1 | CONTROLS ON button | 3 | EMERGENCY STOP button |
| 2 | LOCAL/REMOTE key switch | 4 | REMOTE ACTIVE indicator light |

The operation panel turns the control circuit inside the pump on and off and controls local and remote pump operation.

The CONTROLS ON button turns on the control circuit inside the pump.

When the LOCAL/REMOTE key switch is set to LOCAL, the operator interface is used to run the pump. When the key switch is set to REMOTE:

- The remote source, such as a computer numerical control (CNC) operator console, controls the pump.
- The REMOTE ACTIVE indicator light is on.
- Most of the functions on the operator interface are disabled.



The pump off symbol is functional.

The EMERGENCY STOP button turns off the control circuit inside the pump. When the EMERGENCY STOP button is pushed:

- The control circuit turns off, which turns off the pump, the primary motor, and the intensifier.
- The bleed-down valve opens and discharges water from the system.
- The CONTROLS ON button indicator light turns off.

Primary breaker disconnect lever

The primary breaker disconnect lever disconnects electricity to the pump motor and controls.

Inspect the equipment before operation

Examine the equipment before starting the equipment.

- Look for leaks, deterioration, damage, or other conditions that can interfere with operation.
- Make sure that all connections and fasteners are tight, including locking devices, bolts, hoses, and fittings.
- Make sure that all operational and instructional marks are present and legible.
- Look at the sight gauge on the hydraulic fluid tank. If necessary, add hydraulic fluid.
- Make sure that the water to the pump is turned on.
- Make sure that the electrical main is turned on.
- Make sure that the primary breaker disconnect lever on the electrical enclosure door is set to ON.
- If the equipment was turned off because of a fault, correct the fault.
- If the equipment was turned off because the EMERGENCY STOP button was pushed, reset the button on the operation panel by turning it in the direction of the arrows (clockwise) until it pops out.

Turn on the pump

The primary motor drives a primary hydraulic pump that moves hydraulic fluid through the intensifier and a gear pump that moves hydraulic fluid through the cooling loop. In this section, “pump on” means that the primary motor is running and the pumps are on. “Pump off” means that the motor and the pumps are off.

Turn on the pump locally

 <p>WARNING</p>	Do not leave waterjet cutting equipment turned on and unattended.
---	---

The operator interface is the primary point of control.

1. Push the CONTROLS ON button to turn ON the control circuit inside the pump.

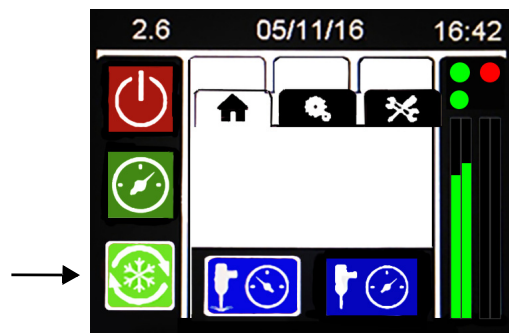

 The pump can not be turned on until the control circuit is on.

2. Turn the cut-pressure control knob anticlockwise until it stops. This extends the life of the high-pressure seals and other high-pressure parts.
3. Touch the symbol on the operator interface to turn ON the pump in cooling mode. Pressure in the system increases until it reaches the setpoint.



4 – Operation

4. Monitor for leaks. Identify the source of a leak and correct the problem. Refer to **Leaks** on page 163.



 WARNING	Do not attempt to repair a leak with pressure in the system.
 WARNING	Use a piece of cardboard or other solid material to check for leaks when the pump is on. Do not use hands, cloth, paper, or towels.

Turn on the pump remotely

 WARNING	Do not leave waterjet cutting equipment turned on and unattended.
---	---

1. Make sure that the key switch is set to LOCAL.
2. Push the CONTROLS ON button.
3. Turn the key switch to REMOTE.
4. Refer to the OEM's instructions for turning the pump on.

Operate the pump

 <p>CAUTION</p>	<p>When an original equipment manufacturer (OEM) or a system integrator makes a cutting system by combining Hypertherm equipment with other equipment, the end-use customer and the OEM or the system integrator are responsible for providing protection against hazardous moving parts. Hypertherm Inc. recommends taking these actions to prevent operator injury and equipment damage:</p> <ul style="list-style-type: none"> ▪ Read and understand the instruction manual supplied by the OEM or the system integrator. ▪ Maintain a restricted-access area larger than the maximum movement range of the cutting equipment's moving parts. ▪ Where there is a risk of a collision, do not permit people or equipment near the cutting equipment's moving parts. ▪ Prevent accidental contact with the touchscreen or joystick on the computer numerical control (CNC) machine. Accidental contact can cause unexpected operation. ▪ Do not do maintenance, repair, or clean the machinery while it is running. (Some maintenance procedures require the pump to be on.) ▪ If maintenance or repair is required, disconnect and lock out or tag out the primary power to disable the motors and prevent motion. Refer to Safety on page 70 for additional information. ▪ Permit only qualified people to operate, maintain, and repair this machinery. Refer to page 20 for more information.
 <p>CAUTION</p>	<p>Make sure that value on the prefilter water-pressure gauge is between 3.45 bar and 7.93 bar or 344.74 kPa and 792.90 kPa (50 psi to 115 psi). If the pressure is not in this range, refer to Adjust the boost pump pressure on page 201.</p>

Operator interface

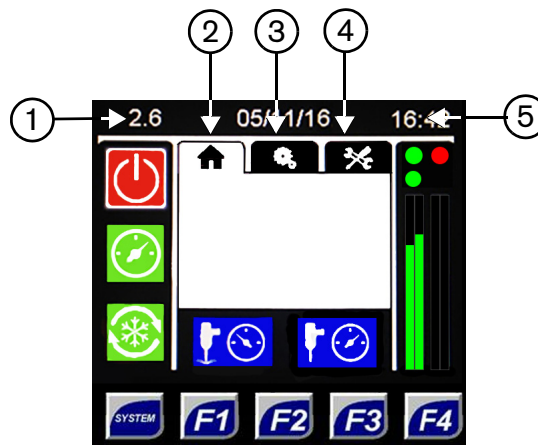

- | | | | |
|---|---------------------|---|------------------------|
| 1 | Hour meter | 4 | Maintenance screen tab |
| 2 | Primary screen tab | 5 | Date and time |
| 3 | Settings screen tab | | |

The hour meter on the top left of the operator interface screen shows the total hours the pump has been in operation. The current date and time are on the top right. These are on every screen.

 The date can be shown in 2 formats: dd/mm/yy or mm/dd/yy. Refer to page 56 for instructions for setting the date.

4 – Operation

Three screens are used to operate the pump: the primary screen, the settings screen, and the maintenance screen.

Primary screen

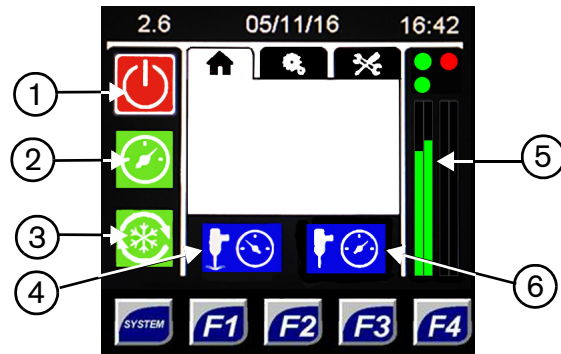

- | | |
|-------------------|---|
| 1 Pump off | 4 Pierce-pressure mode |
| 2 Pump on | 5 Intensifier and pump status indicator |
| 3 Cooling mode on | 6 Cut-pressure mode |

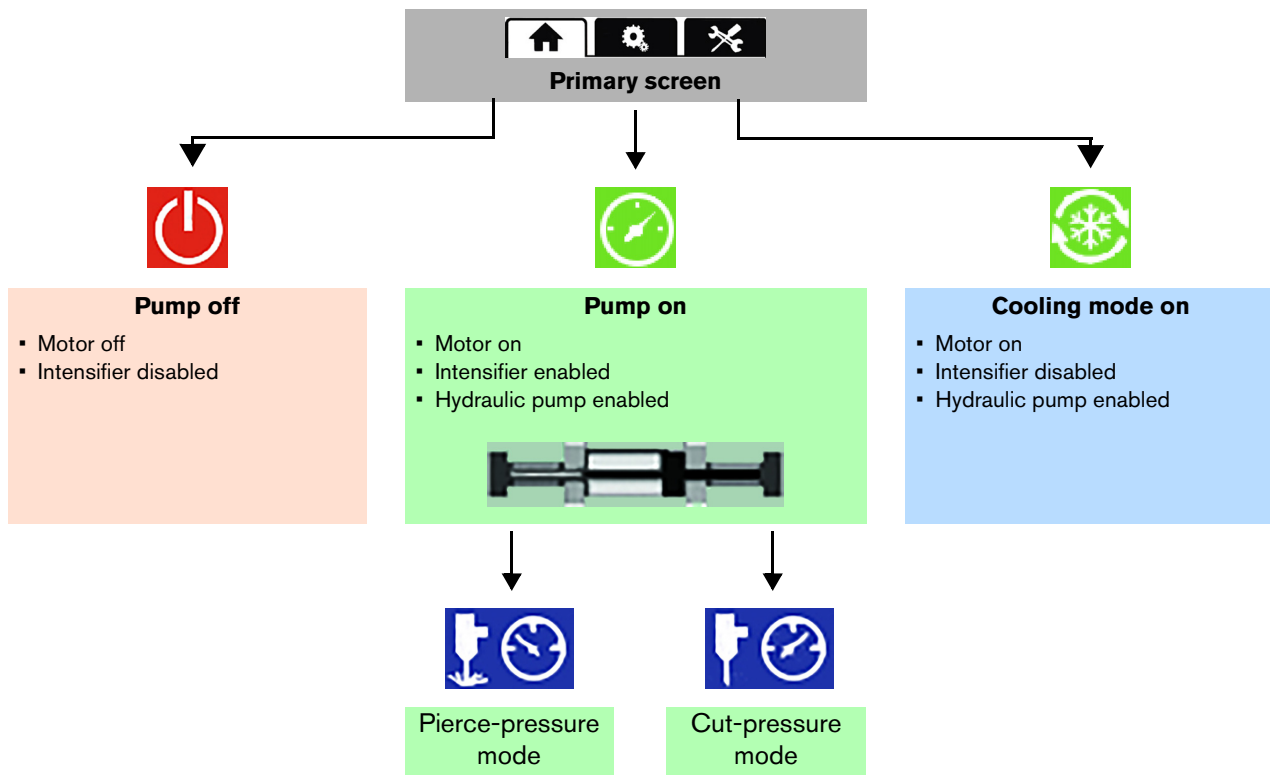

Pump off

Touch this symbol to disable the intensifier and turn OFF the primary motor.

Pump on

Touch this symbol to turn ON the primary motor and to enable the intensifier. Pressure in the system increases until it reaches the setpoint. When the pump is on, the primary screen shows a stroking intensifier.

4 – Operation

Cooling mode on

Touch this symbol to turn ON the primary motor. The pump runs with the intensifier disabled. Hydraulic fluid circulates through the pump at minimum pressure, the cutting-water solenoid is open, and the boost pump is on.

Pressure mode

Touch these symbols to run the pump in pierce-pressure mode or cut-pressure mode.

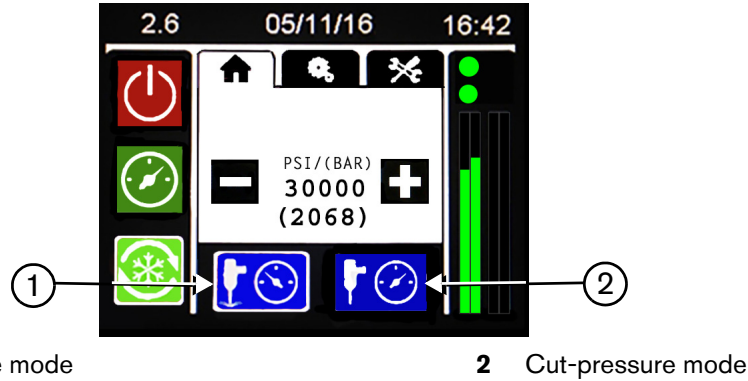

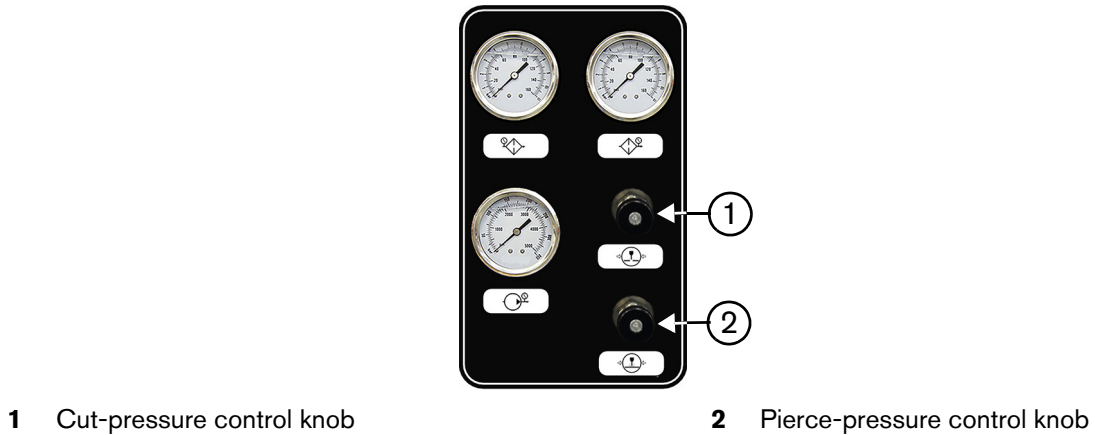

Manual pressure adjustment

On a pump without a proportional control valve, use the pierce-pressure control knob and the cut-pressure control knob to adjust pressures manually.



Turn the knobs clockwise to increase pressure. Turn the knobs anticlockwise to decrease pressure.

 If the cut-pressure mode setpoint is less than the pierce-pressure mode setpoint, the pump operates at the lower pressure.

 When turning off the pump, turn the cut-pressure control knob anticlockwise until it stops. This extends the life of the high-pressure seals and other high-pressure parts.

4 – Operation

Automatic pressure adjustment

On a pump with a proportional control valve, an adjustment screen permits the operator to change the pressure settings.

Touch the - or + symbol to change the pressure setting.

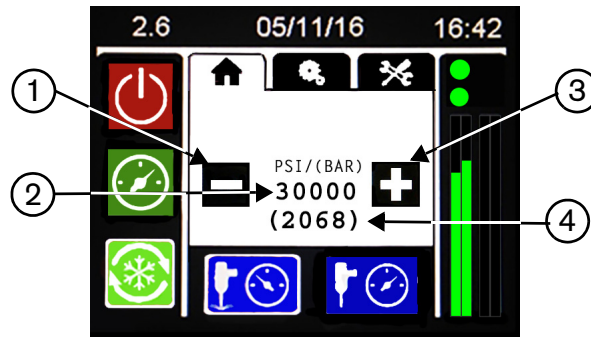

- | | | | |
|---|--------------------------|---|--------------------------|
| 1 | Decrease pressure symbol | 3 | Increase pressure symbol |
| 2 | Pressure setting (psi) | 4 | Pressure setting (bar) |

This setting overwrites the value set on the pressure adjustment screen. Refer to **Pressure adjustment** on page 60 for more information.

The pressure setting can be set as low as 0, but the actual minimum pressure is 551.58 bar (8,000 psi).

Intensifier and pump status indicator

The examples in this section are for a pump with a redundant intensifier. If the pump has 1 intensifier, only 1 indicator is shown on the screen.

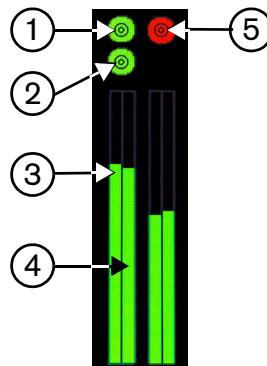

- | | | | |
|---|--|---|-----------------------------------|
| 1 | Intensifier 1 enabled or disabled | 5 | Intensifier 2 enabled or disabled |
| 2 | Pump 1 enabled or disabled | | |
| 3 | Intensifier 1 stroke rate to the left | | |
| 4 | Intensifier 1 stroke rate to the right | | |

Intensifier and pump status indicators show the status of each pump and intensifier. Green shows enabled status. Red shows disabled status.

4 – Operation

The indicator bars show the stroke rate for the intensifier. A green bar shows that the intensifier stroke rate is within the allowable range. A yellow bar shows that the stroke rate is at the limit of the allowable range. A red bar shows that the intensifier is overstroking. For troubleshooting, refer to the **Stroking problems** section, which begins on page 159.

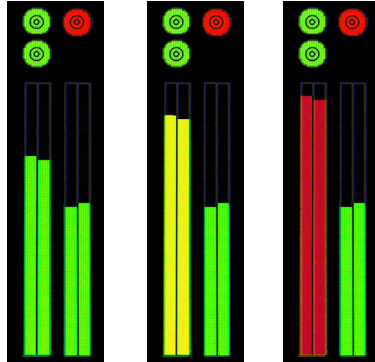

Touch the status indicator to open the intensifier settings screen.

Settings screen

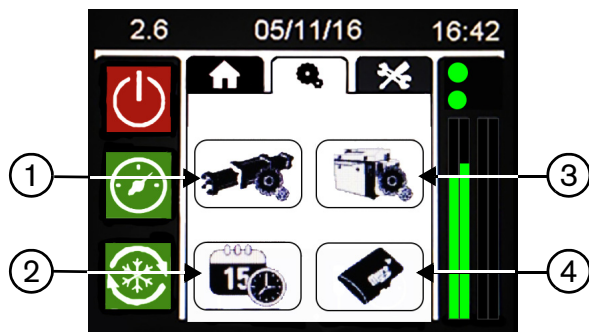

- 1 Intensifier settings screen
- 2 Date and time settings screen
- 3 Pump settings screen
- 4 Micro SD card screen

Operation

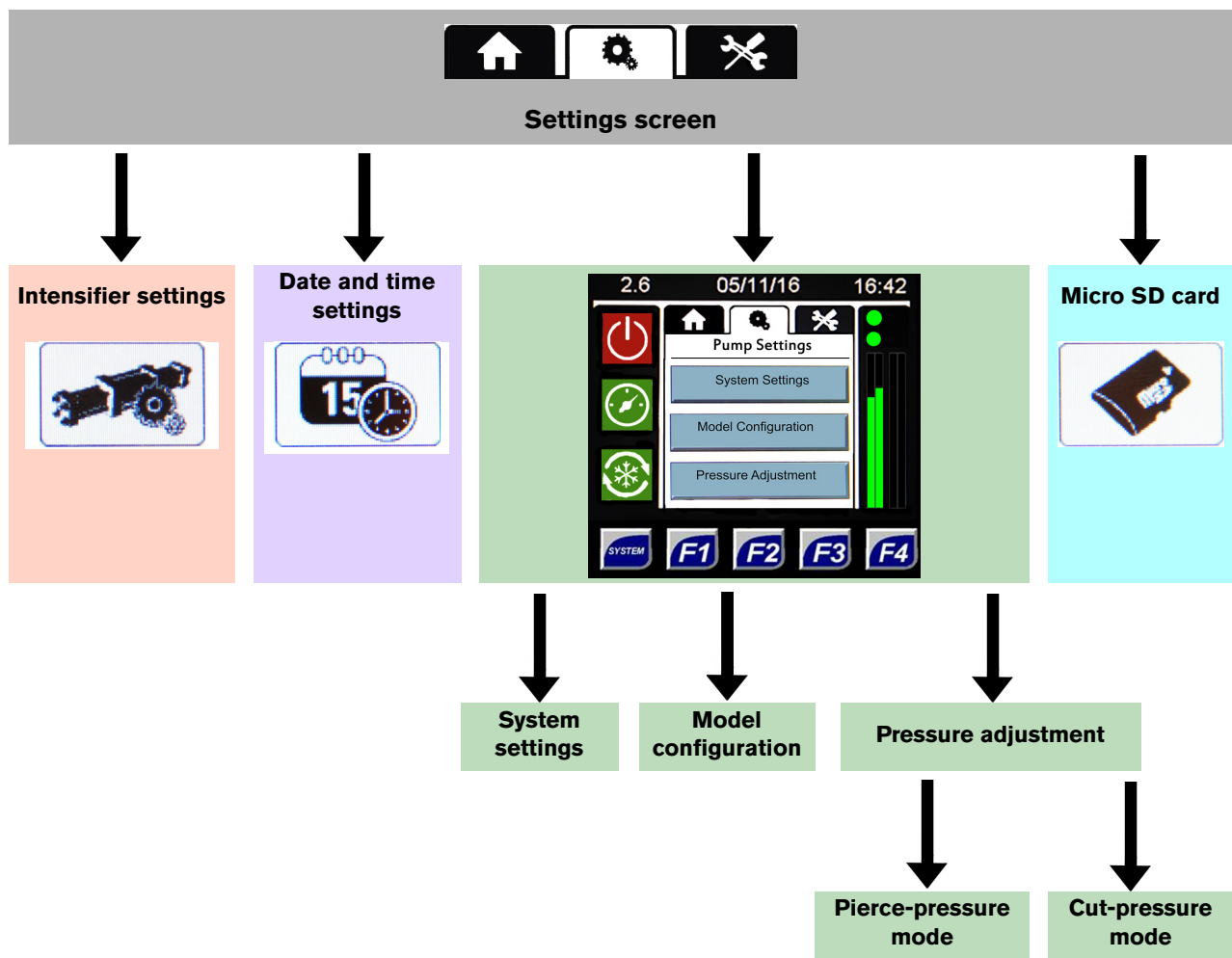

Intensifier settings screen

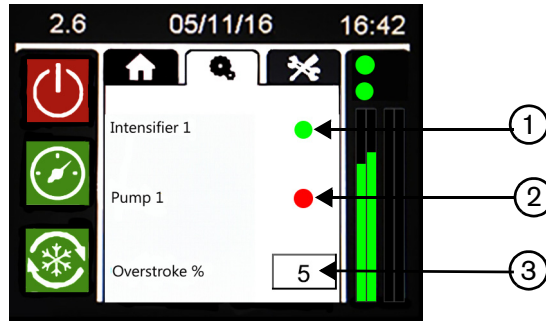

- 1 Enable or disable the intensifier
- 2 Enable or disable the hydraulic pump
- 3 Change the overstroke %

Enable or disable the intensifier and the hydraulic pump

Do this task when the pump is running in cooling mode or is turned off.

Touch the applicable dot on the screen. Green shows enabled status. Red shows disabled status.

Change the overstroke %

Do this task when the pump is running in cooling mode or is turned off.

1. Touch the overstroke % field to open a numeric keypad.

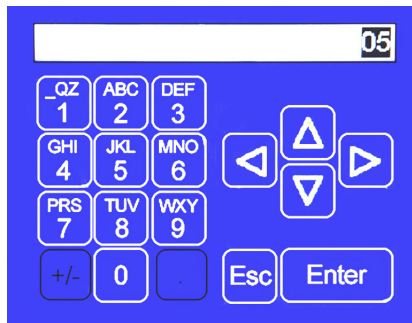

2. Use the numeric keypad to change the overstroke percentage.

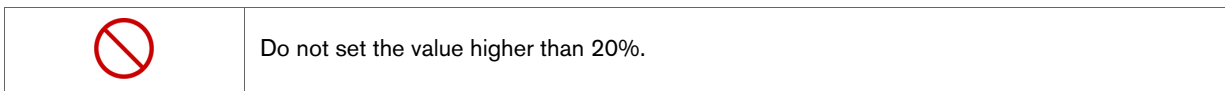

3. Touch Enter to accept the change.

4 – Operation

Date and time settings screen

Use this screen to set the date and time.

1. Touch the time field to open a numeric keypad.
2. Use the left and right arrows to highlight the hours, minutes, or seconds.
3. Use the up and down arrows to increase or decrease the number.
4. Touch Enter to accept the change.
5. Use the same procedure to change the date.

Touch the date field to change the way the date is shown. Options are day/month/year or month/day/year.

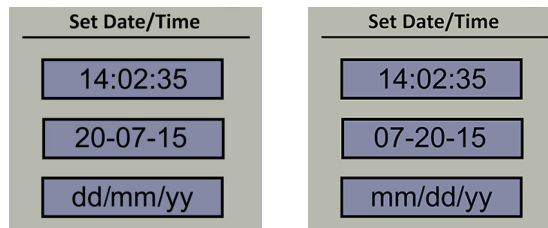

Pump settings screen

The pump settings screen provides access to the system settings menu, the pump set up (configuration), and to the pressure adjustment screen.

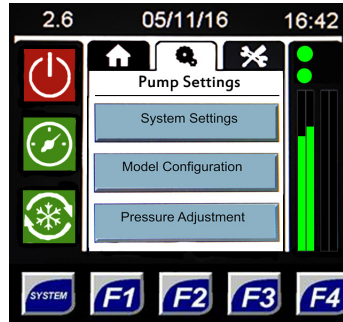

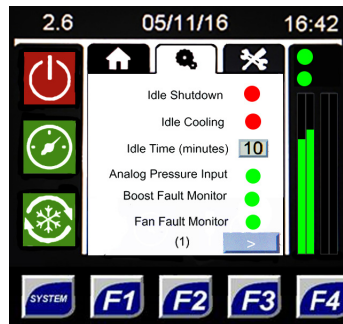

System settings allow the user to enable and disable pump options. If the system has a proportional control valve, the settings for proportional ramping are found here.



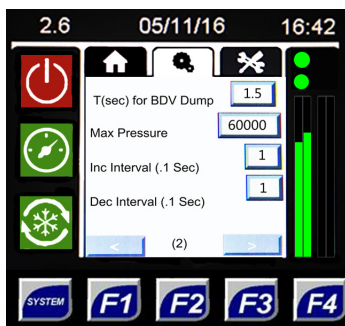



Idle Shutdown	When enabled, the pump turns off after a specified time (Idle Time) without the intensifier stroking.
Idle Cooling	When enabled, the pump goes into cooling mode after a specified time (Idle Time) without the intensifier stroking.
Idle Time (minutes)	Set the number of minutes for Idle Shutdown and Idle Cooling.
Analog Pressure Input	Enable this when a remote 0 V to 10 V input is used to control the proportional valve.
Boost Fault Monitor	When enabled, fault monitoring alerts the operator to a boost pump fault.
Fan Fault Monitor	When enabled, fault monitoring alerts the operator to a fan motor fault. <div style="display: flex; align-items: center;"> This is for air-cooled systems. </div>

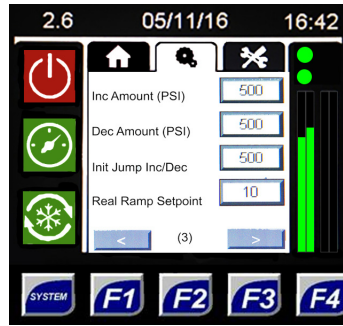

T(sec) for BDV Dump	Set the number of seconds that the bleed-down valve is open when changing from cut-pressure mode to pierce-pressure mode.
Max Pressure	Set the maximum pressure at which the pump can be operated.  This is only applicable for pumps with a proportional control valve.
Inc Interval (.1 sec)	Set the time between steps during ramping up when adjusting the pressure manually on the operator interface.  This is only applicable for pumps with a proportional control valve.
Dec Interval (.1 sec)	Set the time between steps during ramping down when adjusting the pressure manually on the operator interface.  This is only applicable for pumps with a proportional control valve.



Inc Amount (PSI)	<p>Set the increment for increasing pressure.</p> <p> The default value is 500 psi.</p>
Dec Amount (PSI)	<p>Set the increment for decreasing pressure.</p> <p> The default value is 500 psi.</p>
Init Jump Inc/Dec	<p>Set the initial jump amount for increasing or decreasing pressure.</p> <p> The default value is 500 psi.</p>
Real Ramp Setpoint	<p>Set how quickly the pump ramps up to the specified pressure.</p> <p> The higher the value, the faster the pump ramps up.</p> <p> The default value is 10 seconds.</p>

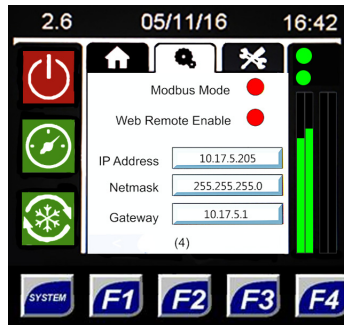

Modbus Mode	When enabled, the pump is controlled by Modbus TCP over Ethernet.  This is disabled for most applications.
Web Remote Enable	Not used
IP Address	This information is required to use a computer network for remote operation of the pump. Contact a Hypertherm Technical Service Associate for assistance.
Net Mask	
Gateway	

The **model configuration** screen shows the current pump setup information.

The **pressure adjustment** screen permits the user of a pump with a proportional control valve to enter the

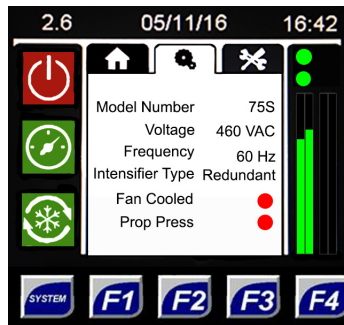

setpoints for pierce-pressure mode and cut-pressure mode that the pump ramps up to when it is turned on. These settings are overridden if the settings are adjusted on the primary screen (refer to page 52 for more information). The adjusted pressure is saved in the controller settings.

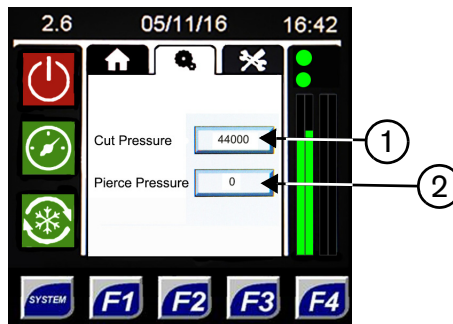

1 Cut-pressure mode setpoint

2 Pierce-pressure mode setpoint

To adjust either pressure, touch the applicable field on the operator interface and enter a value.

4 – Operation

Micro SD card

The micro SD card stores the current program and the alarm logging files. Use this screen to see the contents of the micro SD card.

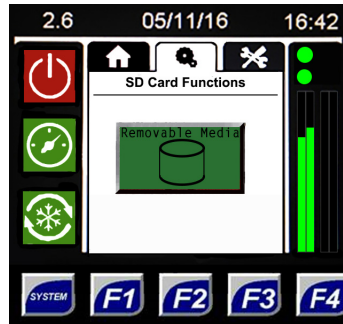

 If the screen shows Removable Media in red, the micro SD card is missing or damaged.

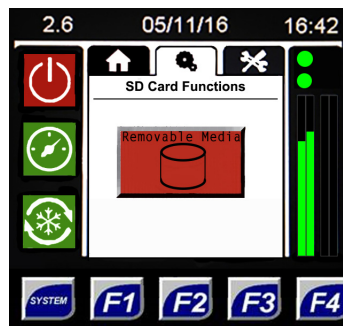

For more information about the micro SD card, contact a Hypertherm Technical Service Associate for assistance.

4 – Operation

Maintenance screen

The maintenance screens permit the user to log and track all maintenance performed on the pump and the intensifier. The user can also move the intensifier to the left or to the right before doing maintenance.

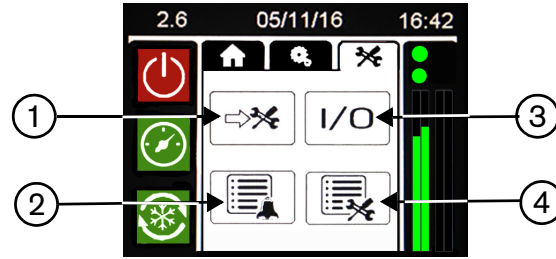

- 1 Pump maintenance
- 2 Alarm log

- 3 Input/output status
- 4 Maintenance log

Pump maintenance

Intensifier maintenance

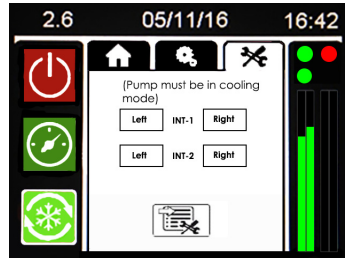

The pump must be in cooling mode to use this feature.

Touch the applicable symbol to move the intensifier to the left or to the right. Doing maintenance on a high-pressure end is much easier when the plunger is moved to that end.

 Pumps without a redundant intensifier do not have the option to move the rear intensifier.

Maintenance log

Touch the applicable area on the image of the pump. Select the area where maintenance was performed. Select each item and the reason for the maintenance.



4 – Operation

Reason for maintenance

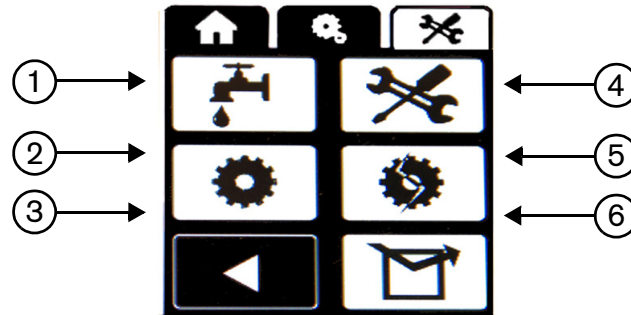

- | | |
|---|---|
| 1 Part is leaking | 4 General preventive maintenance |
| 2 Part is worn | 5 Part is cracked |
| 3 Return to the maintenance options screen | 6 Other reason |

This information transfers to the maintenance log and is saved as a .CSV file on the SD card.

Alarm log

The alarm log shows recent alarms and when they occurred. This can be helpful for troubleshooting.

4 – Operation

Input/output status

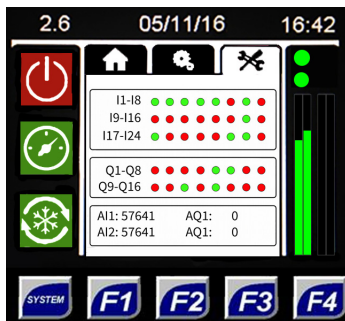

This screen shows all inputs and outputs on the controller. Green shows enabled status. Red shows disabled status. These can be helpful for troubleshooting.

I1	Hydraulic fluid level
I2	Hydraulic fluid temperature is higher than 55°C
I3	Hydraulic fluid temperature is higher than 65°C
I4	Hydraulic fluid temperature is higher than 45°C
I5	Supply water pressure is 40 psi or higher
I6	Front intensifier left proximity switch
I7	Front intensifier right proximity switch
I8	Rear intensifier left proximity switch
I9	Not used
I10	Not used
I11	Not used
I12	Not used
I13	Rear intensifier right proximity switch
I14	Not used
I15	Control on
I16	Remote mode active
I17	Remote pump on
I18	Remote pump off
I19	Remote cooling on
I20	Remote pierce-pressure enable
I21	Primary motor fault
I22	Primary motor run
I23	Boost pump run
I24	Air cooler fan run

4 – Operation

Q1	Enable pump pressure
Q2	Not used
Q3	Low pressure
Q4	Pump run
Q5	Fan motor on
Q6	Enable bleed-down valve
Q7	Front left shift valve solenoid
Q8	Front left shift valve solenoid
Q9	Rear left shift valve solenoid
Q10	Rear right shift valve solenoid
Q11	Reset remote
Q12	Primary motor on
Q13	Boost pump motor on
Q14	Remote fault light
Q15	Red stack light
Q16	Amber stack light

Maintenance log



This screen is not functional. Touching the symbol opens the pump settings screen.

Alarm screens

When the controller detects a fault condition, an alarm screen shows information about the problem and the stack light blinks. If this occurs, refer to the **Alarm screens** section, which begins on page 158.

Operate the pump remotely

Refer to the remote source manufacturer's instructions for operating the pump from a remote source.

CONTROLS ON	<p>This turns on the control circuit inside the pump.</p> <p> The pump can not be turned on until the control circuit is on.</p>
EMERGENCY STOP	<p>The EMERGENCY STOP button is available on the operation panel and at the remote control source.</p> <p> If the pump is running, this turns off the pump. The EMERGENCY STOP button is intended for urgent disabling of the controls. It is not the preferred method of turning off the pump.</p>
PUMP ON	<p>If the pump is off, this enables the fan motor starter and turns on the primary motor, the boost pump, and the low-pressure water. When the motor is at operating speed, the intensifier strokes in pierce-pressure mode for a time that is set at the operator interface. When the timer expires, the intensifier strokes in cut-pressure mode.</p> <p>If the pressure control is set to pierce-pressure mode, the pump starts and stays in pierce-pressure mode.</p> <p>If the pump is in cooling mode, the intensifier strokes.</p>
PUMP OFF	<p>This turns off the intensifier, the boost pump, the primary motor, the low-pressure water, and the cooling fan.</p> <p>In air-cooled systems, it also turns off the fan motor starter and the cooling fan.</p> <p> It is recommended that the pump not be turned off for stand-by status between programs or jobs.</p>
COOLING ON	<p>If the pump is running, this turns off the intensifier. The pump runs at the minimum hydraulic pressure (551.58 bar/8000 psi).</p> <p>If the pump is off, this turns on the primary motor and the cooling water or the cooling fan.</p>

 If the pump is connected to a remote source and is using the remote CONTROLS ON function, refer to the remote source manufacturer's instructions for an emergency stop reset.

Stop the pump

Emergency stop

The EMERGENCY STOP button is intended for urgent disabling of the controls. It is not the preferred method of turning off the pump.

Push the EMERGENCY STOP button.

- The control circuit turns off, which turns off the pump, the primary motor, and the intensifier.
- The bleed-down valve opens and discharges water from the system.
- The CONTROLS ON button indicator light turns off.

Routine stop during operation

1. Turn OFF the cutting head.
2. Touch the symbol on the operator interface to turn OFF the pump. The bleed-down valve opens and discharges water from the system.

Turn off the pump at the end of the day

1. Turn OFF the cutting head.
2. Touch the symbol on the operator interface to turn OFF the pump. The bleed-down valve opens and discharges water from the system.
3. Turn the cut-pressure control knob anticlockwise until it stops.
4. Before turning off the pump, turn the cut-pressure control knob anticlockwise to decrease pressure.
5. Turn OFF the primary breaker disconnect lever on the electrical enclosure door.
6. Turn OFF the water to the pump.
7. Clean all water and hydraulic fluid off of the top and bottom decks.

Section 5

Preventive maintenance

Hypertherm products are designed and manufactured with a commitment to continuous quality control and safety. Contact a Hypertherm Technical Service Associate for information and support regarding the installation, operation, maintenance, and repair of this equipment.

Hypertherm Inc. recommends preventive and scheduled maintenance for HyPrecision pumps. High-quality equipment that is serviced on a schedule lasts longer than equipment that is not maintained regularly. This maintenance includes, but is not limited to, adjustments, cleaning, lubrication, repairs, and replacement of parts.









Benefits of preventive maintenance

- Improves reliability
- Finds potential problems before they cause unplanned downtime and become expensive repairs
- Extends the life of equipment and decreases the frequency of replacement
- Contributes positively to reputation and profits
- Creates traceability through records

Safety

	<p>Refer to the instruction manual. Read and understand all of the safety guidelines in this manual.</p>
 DANGER	<p>Dangerous voltage To reduce the risk of serious injuries or death, wear approved protection and follow safety recommendations when working with electricity.</p>
 WARNING	<p>People who maintain and repair this equipment can be injured or killed if hazardous energy is not properly controlled. Injuries can include burns, cuts, fractures, or electrocution. Turn off electrical power and relieve all water and hydraulic pressure from the pump before starting maintenance or repairs. Disconnect and lock out or tag out the electrical main before opening the electrical enclosure or doing maintenance or repair procedures. Refer to page 97 for additional information.</p>
 WARNING	<p>People who work on deenergized machinery can be seriously injured or killed if someone removes lock-out or tag-out devices and reenergizes machinery without their knowledge. All workers must respect lock-out and tag-out devices and that only the person(s) who applied these devices remove them.</p>
 WARNING	<p>A waterjet is a cutting tool. A high-pressure injection injury is a surgical emergency. Seek immediate medical treatment for all high-pressure waterjet injuries. Delayed treatment can cause serious injuries or death. Keep skin away from high-pressure streams and leaks. Pressurized fluid can cause severe injuries. Abrasive waterjets eject a mixture of water and abrasive materials that can be injected into body tissues, leading to a serious infection. Get immediate surgical attention after contact with high-pressure stream of fluid.</p>
 WARNING	<p>Personal protective equipment is recommended. Failure to wear personal protective equipment can cause injuries or death.</p>
 WARNING	<p>Use a piece of cardboard or other solid material to find leaks when the pump is operating. Do not use hands, cloth, paper, or towels.</p>
 WARNING	<p>Do not repair a leak with high-pressure water in the system. Discharge all high-pressure water before working on this equipment.</p>
 WARNING	<p>Do not touch a hot surface. Fittings can get hot, especially when they are not tightened properly.</p>
 CAUTION	<p>Support all plumbing to prevent bending stress and fatigue from vibration. A disruption or crack in plumbing can cause injuries to people or damage to equipment.</p>
	<p>High-pressure water can cause eye injuries. Wear approved eye protection when operating or working near this equipment.</p>
	<p>This waterjet equipment might exceed national and local codes for permitted noise levels. When this pump is running, the noise level is 75 dB(A) to 80 dB(A). Noise level is related to factors such as water flow rate, pipe layout, and the acoustical characteristics of the building. Prolonged exposure to noise can cause permanent hearing loss. Wear approved ear protection and control exposure time when operating or working near this equipment.</p>
	<p>Precision parts have sharp corners or edges. Wear protective gloves when handling parts.</p>

5 – Preventive maintenance

	Some materials produce airborne contaminants or suspended particles when cut. Wear approved respiratory protection.
	Do not operate the pump without the shaft access cover and all other safety devices in position. Do not remove guards while the pump is running.
	Follow all safety requirements and applicable safety laws and regulations.
	Coordinate preventive maintenance and repair activities with operations and safety staff.
	Examine and clean the equipment regularly. Make repairs immediately.
	Use proper tools for maintenance procedures. Some tools are designed to make the procedure easier and to prevent damage to the equipment.
	People who maintain and repair this equipment must know how to use standard hand tools.
	Before reassembling high-pressure or hydraulic parts, clean the parts to remove dirt and other contaminants.
	Put the parts on a clean, dry, oil-free surface.

Training

The employer must provide training for maintenance activities and retraining for all workers whenever there is a change in job assignments, machinery or processes that present a new hazard, or energy-control procedures, or when a periodic inspection reveals, or an employer has reason to believe, that shortcomings exist in a worker's knowledge or use of the energy-control procedure.

Tips

- Keep the work area clean and free of fluid spills. Use catch basins under areas where water or hydraulic fluid can spill during maintenance or repair procedures.
- Keep accurate maintenance records.
- Keep parts available so that they are ready when required.
- Follow local protocols for recycling or disposal of parts and materials. Refer to **Recycling and end of product life** on page 146.

Preventive maintenance schedule



Repair or replace parts identified in the preventive maintenance schedule or if the parts show deterioration, corrosion, or damage.

These maintenance intervals are general guidelines. The top left of the operator interface screen shows the total hours the pump has been in operation.

	Every work shift	Every 40 hours	Every 500 hours	Every 1,000 hours	Every 1,500 hours	Every 3,000 hours
General (page 75)						
Examine the equipment for leaks or damage	page 75					
Electrical system (page 76)						
Make sure that the emergency stop button works	page 76					
Examine cords and plugs for deterioration or damage	page 76					
Hydraulic system (page 77)						
Check the hydraulic fluid indicator	page 77					
Check the hydraulic fluid level	page 78					
Check the hydraulic fluid quality	page 80					
Measure the hydraulic fluid temperature		page 81				
Replace the hydraulic filter					page 83	
Replace the hydraulic fluid, the hydraulic filter, the filler-breather cap, and the suction strainers						page 84
Low-pressure water system (page 88)						
Check the low-pressure water pressure gauges	page 88					
Measure the air pressure in the water accumulator tank			page 89			
Replace the water filters				page 91		
Test the low-pressure water TDS level				page 94		

5 – Preventive maintenance

	Every 500 hours	Every 1,000 hours	Every 2,000 hours	Every 3,000 hours	Every 6,000 hours	Every 12,000 hours
High-pressure water system: Intensifier (page 96)						
These procedures require disassembling the intensifier (page 97). To reduce downtime, Hypertherm recommends doing preventive maintenance on both ends of the intensifier at the same time.						
Repair the check valves and the low-pressure poppets	page 107					
Repair the high-pressure cylinders	page 109					
Replace the high-pressure seal backups	page 114					
Replace the hydraulic rod seals	page 114					
Replace the seal housing O-rings	page 114					
Replace the seal housing O-ring backups	page 114					
Replace the high-pressure hoops	page 117					
Replace the high-pressure water seals	page 117					
Replace the check valve O-rings	page 117					
Replace the low-pressure poppets		page 117				
Replace the high-pressure poppet assemblies		page 124				
Replace the check valves			page 117			
Replace the low-pressure poppet baskets			page 117			
Replace the indicator pin spring				page 112		
Replace the plunger bearings				page 114		
Replace the high-pressure cylinders				page 117		
Replace the indicator pin					page 112	
Replace the seal housings					page 114	
Replace the output adapters					page 124	
Replace the spacer tubes						page 117
Repair the hydraulic center section						page 111

5 – Preventive maintenance

	Every 500 hours	Every 1,000 hours	Every 2,000 hours	Every 3,000 hours	Every 6,000 hours	Every 12,000 hours
High-pressure water system: Bleed-down valve (page 129)						
Examine the bleed-down valve for leaks or damage	page 129					
Repair the bleed-down valve		page 130				
Replace the bleed-down valve body				page 140		

Tools

Some maintenance and repair procedures recommend or require special tools. This page is intended to help a user identify tools that are unfamiliar or are known by other names.



Open-ended wrench



Crowfoot wrench



Dental pick



Seal housing removal tool (included in the 12084 HyPrecision standard tool kit)

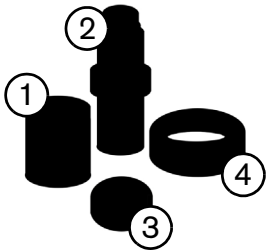



Seal installation tools (included in the 12084 HyPrecision standard tool kit)

- 1 Sleeve
- 2 Push tool
- 3 Spacer
- 4 Locator

Refer to the **Complete list of preventive maintenance kits, parts, tools, and materials** on page 156 for all of the tools needed for preventive maintenance on this equipment.

General

Examine the equipment for leaks or damage

 WARNING	<p>Do not touch a hot surface. Fittings can get hot, especially when they are not tightened properly.</p>
 CAUTION	<p>Failure to correct the cause of a leak can cause damage to the water fittings.</p>

Service	Interval
Examine the equipment for leaks or damage	Before every work shift

Do this task when the pump is running and the system is pressurized.

1. Look for hydraulic fluid leaks. Pay attention to these areas:
 - Hydraulic fluid tank access cover
 - Hydraulic connections
 - Valves
 - Top and bottom decks
2. Examine the low-pressure pipes and the hoses for leaks.
3. Examine the high-pressure tubing for leaks.
4. Examine the weep holes and leak points at both of the high-pressure ends for leaks. Water seeping from a weep hole is a sign of a faulty part, a loose connection, or a damaged connection.

Identify the source of a leak and correct the problem. Refer to **Leaks** on page 163.

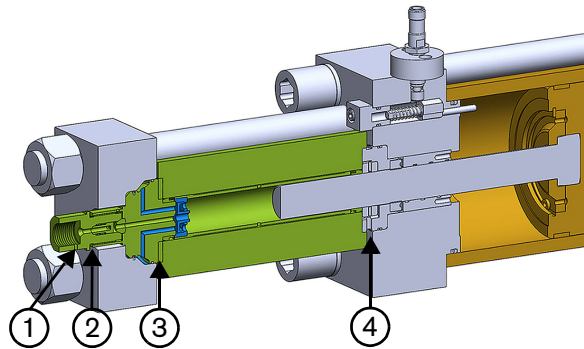

- | | |
|--|--|
| <ol style="list-style-type: none"> 1 Output adapter weep hole 2 High-pressure seat weep hole | <ol style="list-style-type: none"> 3 Static seal leak point 4 Dynamic seal housing weep hole |
|--|--|

Electrical system

Service	Interval
Make sure that the emergency stop button works Examine cords and plugs for deterioration or damage	Before every work shift

Make sure that the emergency stop button works

 If the pump is set up to run remotely and has a motion system (robot or cutting table), the emergency circuits from the robot or cutting table can be wired in series with the local emergency stop circuit.

The EMERGENCY STOP button is available on the operation panel.

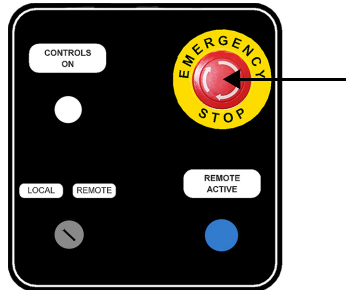



Do this task when the pump is running.

Push the EMERGENCY STOP button.

- The control circuit turns off, which turns off the pump, the primary motor, and the intensifier.
- The bleed-down valve opens and discharges water from the system.
- The CONTROLS ON button indicator light turns off.

Examine cords and plugs for deterioration or damage

 DANGER	Dangerous voltage To reduce the risk of serious injuries or death, wear approved protection and follow safety recommendations when working with electricity.
	When replacing wiring, use only the same size, type, and color as the original wiring.
	Repair or replace parts identified in the preventive maintenance schedule or if the parts show deterioration, corrosion, or damage.

Do this task when the pump is not running.

1. Examine electrical cords for kinks or damage to the insulation.
2. Examine electrical plugs and other electrical connectors for corrosion or damage.

Hydraulic system

Check the hydraulic fluid indicator

Service	Interval
Check the hydraulic fluid indicator	Before every work shift
Replace the hydraulic filter (page 83)	After every 1,500 hours of operation

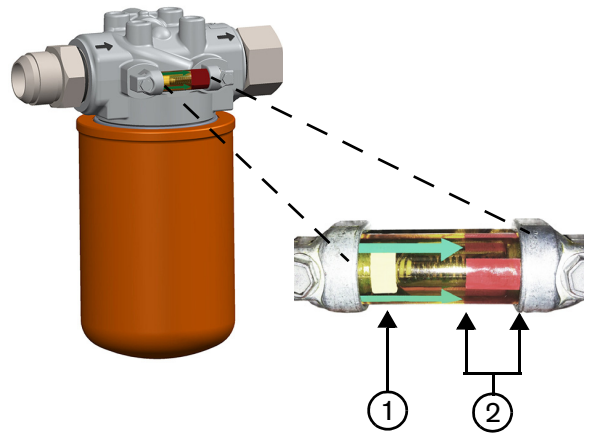

1 White indicator bar

2 Red zone

Do this task when the pump is running at operating temperature.

Replace the filter after every 1,500 hours of operation or when the white indicator bar stays in the red zone while the pump is running at operating temperature. Refer to page 83 for instructions.

5 – Preventive maintenance

Check the hydraulic fluid level

Service	Interval
Check the hydraulic fluid level	Before every work shift

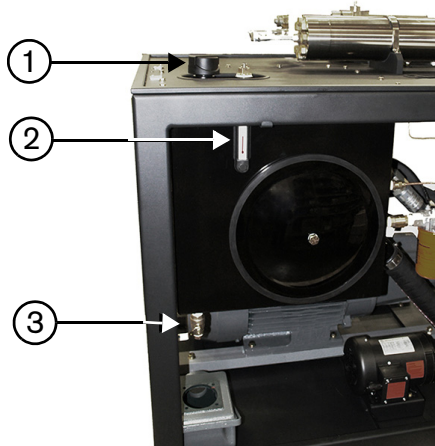



- 1 Filler-breather cap
- 2 Sight gauge

3 Drain valve

Do this task when the pump is running.

Make sure that the hydraulic fluid level is at the top mark on the sight gauge. Add hydraulic fluid, if necessary.

Add hydraulic fluid

 DANGER	People who maintain and repair this equipment can be injured or killed if hazardous energy is not properly controlled. Injuries can include burns, cuts, fractures, or electrocution. Turn off electrical power and relieve all water and hydraulic pressure from the pump before starting maintenance or repairs. Disconnect and lock out or tag out the electrical main before opening the electrical enclosure or doing maintenance or repair procedures. Refer to page 97 for additional information.
 DANGER	People who work on deenergized machinery can be seriously injured or killed if someone removes lock-out or tag-out devices and reenergizes machinery without their knowledge. All workers must respect lock-out and tag-out devices and that only the person(s) who applied these devices remove them.

The capacity of the hydraulic fluid tank is 151 L (40 gallons). For air-cooled systems, increase the hydraulic fluid available by at least 19 liters (5 gallons) to fill the hoses and the air cooler.



Required parts, tools, and materials

Antiwear (AW) mineral oil or synthetic hydraulic fluid, ISO viscosity grade (VG) 32 or 46

Recommended materials

Clean funnel

5 – Preventive maintenance

Do this task when the pump is not running.

1. Make sure that the drain valve is closed.
2. Remove the filler-breather cap on top of the tank.
3. Fill the tank with hydraulic fluid until the fluid is at the top mark on the sight gauge.





Do not overfill the hydraulic fluid tank.

4. Install the original filler-breather cap.

5 – Preventive maintenance

Check the hydraulic fluid quality

 DANGER	<p>People who maintain and repair this equipment can be injured or killed if hazardous energy is not properly controlled. Injuries can include burns, cuts, fractures, or electrocution.</p> <p>Turn off electrical power and relieve all water and hydraulic pressure from the pump before starting maintenance or repairs.</p> <p>Disconnect and lock out or tag out the electrical main before opening the electrical enclosure or doing maintenance or repair procedures. Refer to page 97 for additional information.</p>
 DANGER	<p>People who work on deenergized machinery can be seriously injured or killed if someone removes lock-out or tag-out devices and reenergizes machinery without their knowledge. All workers must respect lock-out and tag-out devices and that only the person(s) who applied these devices remove them.</p>

Service	Interval
Check the hydraulic fluid quality	Before every work shift
Replace the hydraulic fluid, the hydraulic filter, the filler-breather cap, and the suction strainers	<ul style="list-style-type: none"> ▪ If it is dark or milky in color ▪ If it has a strong odor ▪ After every 3,000 hours of operation

 Contact a hydraulic fluid supplier for a precise report on the hydraulic fluid quality.

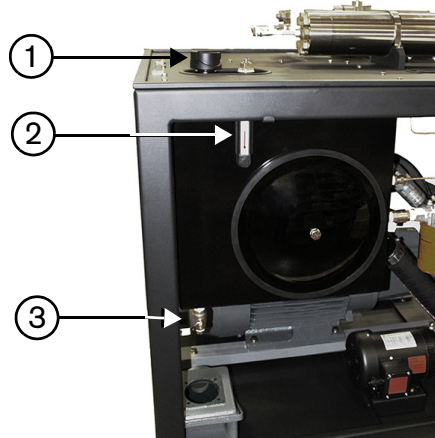

- 1 Filler-breather cap
- 2 Sight gauge



- 3 Drain valve

Do this task when the pump is not running.

1. Make sure that the drain valve is closed.
2. Look through the sight gauge to see the color of the hydraulic fluid. Good hydraulic fluid is almost transparent.
3. Remove the filler-breather cap on top of the tank.
4. Smell the hydraulic fluid. Good hydraulic fluid has almost no odor.

Refer to page 84 for instructions for replacing the hydraulic fluid.

Measure the hydraulic fluid temperature

 CAUTION	Keep the hydraulic fluid temperature in the hydraulic fluid tank between 37.8°C (100°F) and 51.7°C (125°F). Hydraulic fluid that is too hot can deteriorate and cause the pump to fail. Hydraulic fluid that is too cool causes the pump to operate sluggishly.
	Calibrate or check your thermometer for accuracy before use.

Service	Interval
Measure the hydraulic fluid temperature	After every 40 hours of operation



Required parts, tools, and materials

Infrared thermometer



Other types of external-reading thermometers, such as the style that adheres to the outside of machinery, can be used.

Do this task when the pump is running.

1. Remove a side panel from the pump so the hydraulic fluid tank is exposed.
2. Point an infrared thermometer at a large, flat surface on the tank.

The optimum operating temperature for hydraulic fluid in this system is 40.6°C (105°F) to 46.1°C (115°F). If the temperature is outside of this range, adjust the hydraulic fluid temperature. Refer to page 82 for instructions.

5 – Preventive maintenance

Adjust the hydraulic fluid temperature



Calibrate or check your thermometer for accuracy before use.

The optimum operating temperature for hydraulic fluid in this system is 40.6°C (105°F) to 46.1°C (115°F). If the temperature is outside of this range, adjust the hydraulic fluid temperature.



Required parts, tools, and materials

Flat-blade screwdriver (for pumps with a water-modulating valve)

Infrared thermometer



Other types of external-reading thermometers, such as the style that adheres to the outside of machinery, can be used.

Do this task when the pump is running.

Water-cooled system with a heat exchanger

1. Open the valve on the cooling water line to increase the cooling water flow to the chiller. Close the valve on the cooling water line to decrease the cooling water flow.
2. Wait approximately 5 minutes to let the hydraulic fluid temperature stabilize.
3. Check the temperature.
4. Repeat this procedure until the temperature is in range.

Water-cooled system with a water-modulating valve

1. Turn the screw on the top of the water-modulating valve 1/2 turn to the left (anticlockwise) to increase the temperature. Turn the screw on the top of the valve 1/2 turn to the right (clockwise) to decrease the temperature.

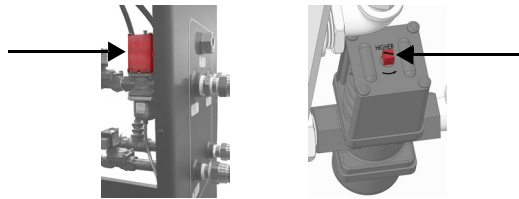





2. Wait approximately 5 minutes to let the hydraulic fluid temperature stabilize.
3. Check the temperature.
4. Repeat this procedure until the temperature is in range.

Air-cooled system

The temperature of an air-cooled system is not adjustable. If the hydraulic fluid temperature is out of range, refer to the **High temperature** section on page 166

Replace the hydraulic filter

 DANGER	<p>People who maintain and repair this equipment can be injured or killed if hazardous energy is not properly controlled. Injuries can include burns, cuts, fractures, or electrocution.</p> <p>Turn off electrical power and relieve all water and hydraulic pressure from the pump before starting maintenance or repairs.</p> <p>Disconnect and lock out or tag out the electrical main before opening the electrical enclosure or doing maintenance or repair procedures. Refer to page 97 for additional information.</p>
 DANGER	<p>People who work on deenergized machinery can be seriously injured or killed if someone removes lock-out or tag-out devices and reenergizes machinery without their knowledge. All workers must respect lock-out and tag-out devices and that only the person(s) who applied these devices remove them.</p>
 CAUTION	<p>Failure to correct the cause of a leak can cause damage to the water fittings.</p>
	<p>Follow local regulations when disposing of used fluids and filters.</p>

Service	Interval
Replace the hydraulic filter	After every 1,500 hours of operation





Required parts, tools, and materials

- 16025 Hydraulic filter (included in the 15569 HyPrecision S-series standard spares kit)
- Antiwear (AW) mineral oil or synthetic hydraulic fluid, ISO viscosity grade (VG) 32 or 46
- Strap wrench or adjustable pliers

Do this task when the pump is not running.

1. Remove the filter from the filter head.
2. Put clean hydraulic fluid on the gasket on the new filter.
3. Twist the filter onto the filter head.
4. Tighten the filter with a strap wrench or adjustable pliers.
5. Turn ON the pump in cooling mode.



Monitor for leaks. Identify the source of a leak and correct the problem. Refer to **Leaks** on page 163.

 WARNING	<p>Do not attempt to repair a leak with pressure in the system.</p>
 WARNING	<p>Use a piece of cardboard or other solid material to check for leaks when the pump is on. Do not use hands, cloth, paper, or towels.</p>

6. Check the hydraulic fluid level. Add hydraulic fluid if necessary. Refer to page 78 for instructions.

5 – Preventive maintenance

Replace the hydraulic fluid, the hydraulic filter, the filler-breather cap, and the suction strainers

 CAUTION	Failure to correct the cause of a leak can cause damage to the water fittings.
	Follow local regulations when disposing of used fluids and filters.
	Install a new hydraulic filter and filler-breather cap when replacing the hydraulic fluid.

Service	Interval
Replace the hydraulic filter	After every 1,500 hours of operation
Replace the hydraulic fluid and the suction strainers	After every 3,000 hours of operation

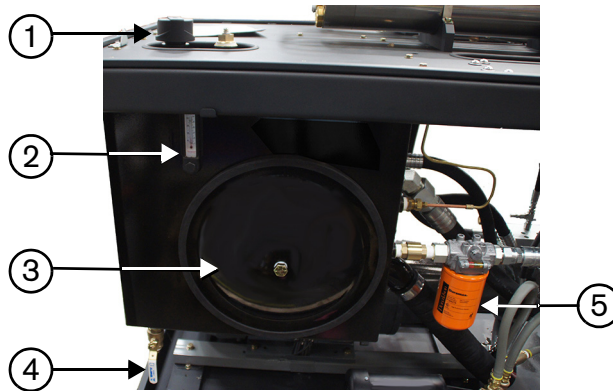

- 1 Filler-breather cap
- 2 Sight gauge
- 3 Access cover
- 4 Drain valve plug and lever

- 5 Hydraulic filter

5 – Preventive maintenance



Required parts, tools, and materials

12438 Suction strainer, 1-1/2 inch

11960 Suction strainer, 2-1/2 inch

14629 Filler-breather cap

16025 Hydraulic filter (included in the 15569 HyPrecision S-series standard spares kit)

Antiwear (AW) mineral oil or synthetic hydraulic fluid, ISO viscosity grade (VG) 32 or 46

Clean, lint-free towels

Isopropyl alcohol

Standard 9/16-inch open-ended wrench or socket (drain valve plug)

Standard 3/4-inch crowfoot wrench or socket (access cover)

Torque wrench

Strap wrench or adjustable pliers

Hose or pipe for draining hydraulic fluid

Container for used hydraulic fluid

Recommended materials

Clean funnel

Do this task when the pump is not running.

1. Remove the drain valve plug.
2. Open the drain valve lever on the bottom of the hydraulic fluid tank.



Use a hose or a pipe to direct the hydraulic fluid into a container.

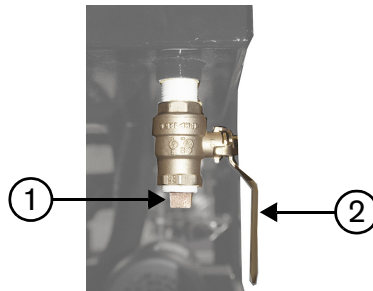

1 Drain valve plug

2 Drain valve lever

3. Disconnect the lower ends of the hydraulic hoses to drain them.
4. Install a new hydraulic filter. Refer to page 83 for instructions.
5. Remove the access cover on the tank.

5 – Preventive maintenance

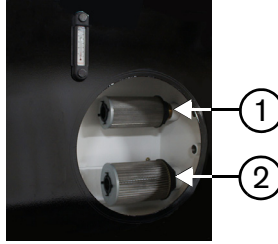

6. Use a strap wrench or adjustable pliers to remove the suction strainers inside the tank.



1 Suction strainer (to the gear pump)

2 Suction strainer (to the primary pump)

7. Clean the inside of the tank with a lint-free towel and isopropyl alcohol. Make sure that no debris is left on the bottom.

 CAUTION	Remove all towels from the tank before it is filled.
	Do not use soap, detergent, or solvents.

8. Install new suction strainers.

 Hand tighten the suction strainer, and then turn it 90 degrees more.

9. Reconnect the hydraulic hoses.

 Refer to the **Torque values** section, which begins on page 181.

10. Close the drain valve.

11. Install the drain valve plug.

12. Replace the access cover on the tank. Torque the nut to 27 N·m (20 lbf·ft).

13. Remove the used filler-breather cap.

14. Fill the tank with hydraulic fluid. Make sure that the hydraulic fluid level is at the top mark on the sight gauge.



	Do not overfill the hydraulic fluid tank.
---	---

15. Install the new filler-breather cap.

16. Discard the used parts.

5 – Preventive maintenance

17. Turn ON the pump in cooling mode. Let it run for 15 to 20 minutes. Monitor for leaks. Identify the source of a leak and correct the problem. Refer to **Leaks** on page 163.

 WARNING	Do not attempt to repair a leak with pressure in the system.
 WARNING	Use a piece of cardboard or other solid material to check for leaks when the pump is on. Do not use hands, cloth, paper, or towels.

18. Add hydraulic fluid. Fill the tank until the fluid is at the top mark on the sight gauge. Repeat this process as needed.

19. Run the pump in pierce-pressure mode for 15 to 20 minutes.

 If air enters the hydraulic system, the pump becomes noisy during operation. Refer to **Noisy operation** on page 171.

Low-pressure water system

Check the low-pressure water pressure gauges

Service	Interval
Check the low-pressure water pressure gauges	Before every work shift
Replace the water filters (page 91)	After every 1,000 hours of operation or if the difference between the values on the pre- and the postfilter water-pressure gauges is higher than 0.69 bar or 68.95 kPa (10 psi)

The prefilter water-pressure gauge shows the water pressure before the water goes through the filters. The postfilter water-pressure gauge shows the water pressure after the water goes through the filters.

The usual operating range is 2.76 bar to 7.58 bar or 275.79 kPa to 758.42 kPa (40 psi to 110 psi).

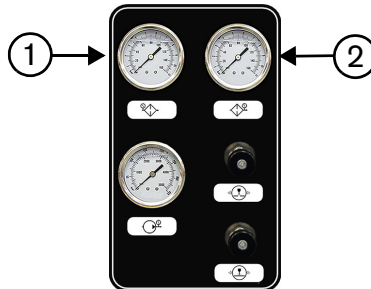

1 Prefilter water-pressure gauge

2 Postfilter water-pressure gauge

Do this task when the pump is running.

Subtract the value shown on the postfilter water pressure from the value shown on the prefilter water pressure.

Replace the filters if the difference between the values on the pre- and the postfilter water-pressure gauges is higher than 0.69 bar or 68.95 kPa (10 psi).

5 – Preventive maintenance

Measure the air pressure in the water accumulator tank

Service	Interval
Measure the air pressure in the water accumulator tank	After every 500 hours of operation

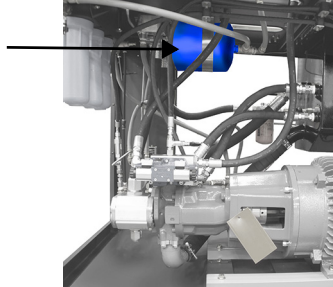

Required parts, tools, and materials

Air pressure gauge (Schrader valve)

Compressed air source

Do this task when the pump is not running.

1. Turn OFF the water to the pump.
2. Open the water valve to drain the water from the system. Make sure that the water pressure gauges show 0.0 bar or 0 kPa (0 psi).

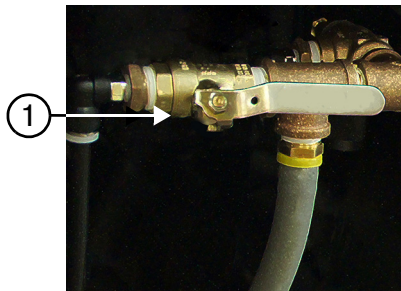

1 Water valve in the open position

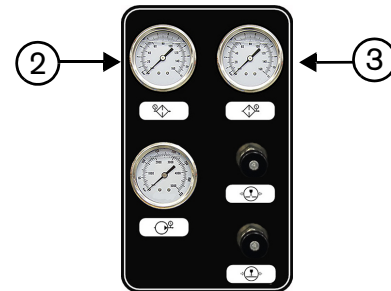

2 Prefilter water pressure

3 Postfilter water pressure

3. Remove the valve stem cap from the water accumulator tank.

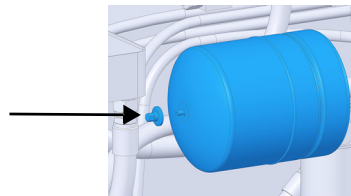

4. Use an air pressure gauge to measure the pressure in the tank. The optimum air pressure is 2.07 bar or 206.84 kPa (30 psi).

5 – Preventive maintenance

5. Add compressed air to increase the pressure in the tank. To reduce pressure in the tank, push on the valve stem to release air.
6. Repeat this procedure until the pressure is 2.07 bar or 206.84 kPa (30 psi).
7. Install the original valve stem cap.
8. Close the water valve.

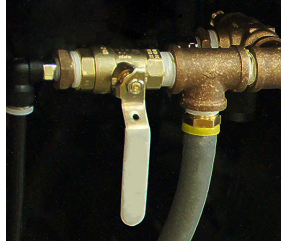



Water valve in the closed position

9. Turn ON the water to the pump.

5 – Preventive maintenance

Replace the water filters

 CAUTION	Failure to correct the cause of a leak can cause damage to the water fittings.
	Replace all of the filters at the same time.

Service	Interval
Replace the water filters	After every 1,000 hours of operation or if the difference between the values on the pre- and the postfilter water-pressure gauges is higher than 0.69 bar or 69 kPa (10 psi)

Hypertherm HyPrecision 50S, 60S, and 75S pumps have 3 filters that remove contaminants from the supply water.



Required parts, tools, and materials

- 11 105 Water filter cartridge, 0.45 micron, 10 inch
- 11 106 Water filter cartridge, 1.0 micron, 10 inch
- 11 107 Water filter cartridge, 10 micron, 10 inch



These parts are included in the 15569 HyPrecision S-series standard spares kit.

Filter wrench (included in the 12084 HyPrecision standard tool kit)

Recommended materials

Bucket or pail

Do this task when the pump is not running.

1. Turn OFF the water to the pump.
2. Open the water valve to drain the water from the system. Make sure that the water pressure gauges show 0.0 bar or 0 kPa (0 psi).

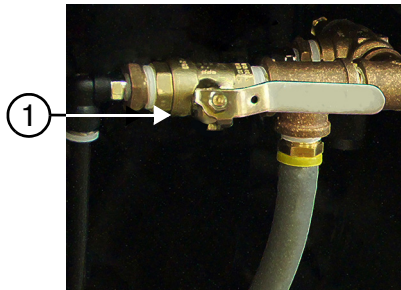

1 Water valve in the open position

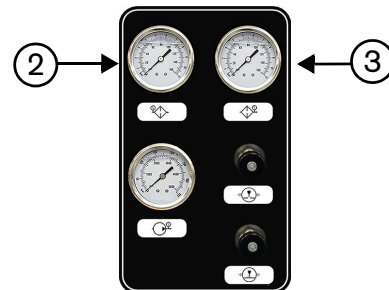

- 2 Prefilter water pressure
- 3 Postfilter water pressure

3. Use a filter wrench to loosen each of the filter housings.

5 – Preventive maintenance

4. Pour the water out of the filter housings.
5. Remove the used filter cartridges from the filter housings.
6. Put a new 0.45-micron filter cartridge in the housing with the plug at the bottom and the gray rubber gasket at the top.
7. Put a new filter cartridge in the 1-micron filter housing and the 10-micron filter housing.



The 1-micron and the 10-micron filters do not have a designated top or bottom.



8. Install the filters and the housings with the 10-micron water filter nearest to the water valve.

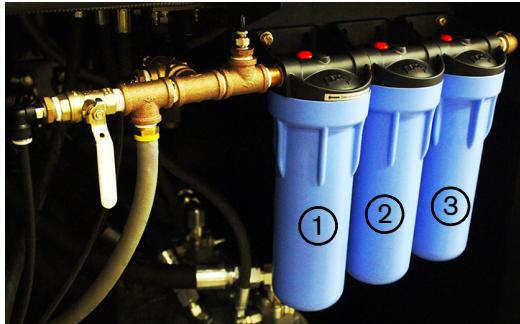

- 1 10-micron water filter
- 2 1-micron water filter

- 3 0.45-micron water filter

9. Discard the used parts.
10. Use a filter wrench to tighten each of the filter housings.
11. Close the water valve.

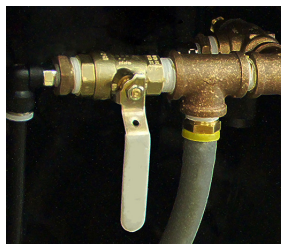

Water valve in the closed position



12. Turn ON the water to the pump.
13. Turn ON the pump in cooling mode.

5 – Preventive maintenance

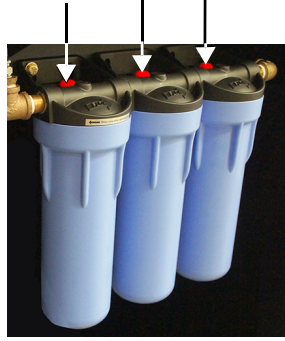
14. Push the water filter purge buttons until water comes out from under each button.



15. Touch the symbol on the operator interface to put the pump in running mode.
16. Make sure that the difference between the values on the pre- and the postfilter water-pressure gauges is less than 0.69 bar or 68.95 kPa (10 psi).
17. Monitor for leaks. Identify the source of a leak and correct the problem. Refer to **Leaks** on page 163.

 WARNING	Do not attempt to repair a leak with pressure in the system.
 WARNING	Use a piece of cardboard or other solid material to check for leaks when the pump is on. Do not use hands, cloth, paper, or towels.

5 – Preventive maintenance

Test the low-pressure water TDS level

Service	Interval
Test the low-pressure water TDS level	After every 1,000 hours of operation

Some TDS meters require calibration before use. For best results, calibrate the meter at 25.0°C (77°F). Refer to the instructions supplied with the TDS meter.

 If multiple readings are taken, turn the meter OFF between readings.

Required parts, tools, and materials

13897 TDS meter

Container for a water sample

Clean, deionized water or filtered water

Do this task when the pump is running in cooling mode.

1. Open the water valve to drain the water from the system. Make sure that the water pressure gauges show 0.0 bar or 0 kPa (0 psi).

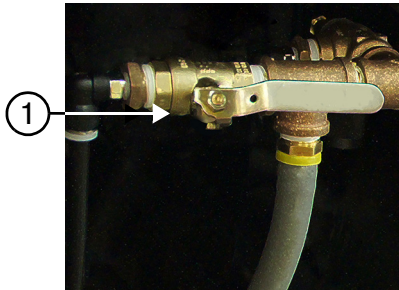

1 Water valve in the open position

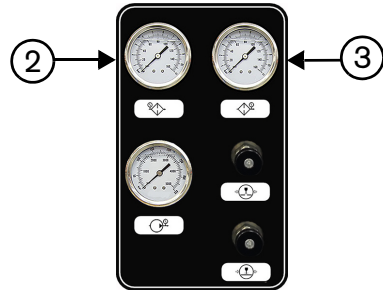

2 Prefilter water pressure

3 Postfilter water pressure

2. Let the water run for 30 seconds.
3. Take a sample from the wastewater outlet. If the wastewater outlet is not accessible, take a sample of the supply water going into the pump.

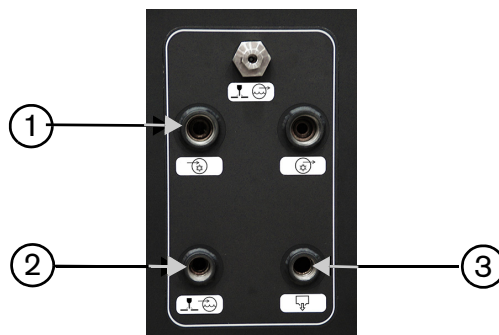

1 COOLING IN

2 CUTTING WATER IN

3 WASTEWATER OUT

5 – Preventive maintenance

4. Put the TDS meter in the water sample up to the maximum immersion level (5 cm/2 inches). Tap the meter gently to release air bubbles.



The meter is not waterproof. Do not submerge the unit in water.

5. Wait approximately 20 seconds for the reading to become stable.
6. Compare the reading to the TDS table on page 189 in the **Installation** section of this manual.
7. Rinse the meter in clean, deionized water or filtered water after use.

High-pressure water system: Intensifier



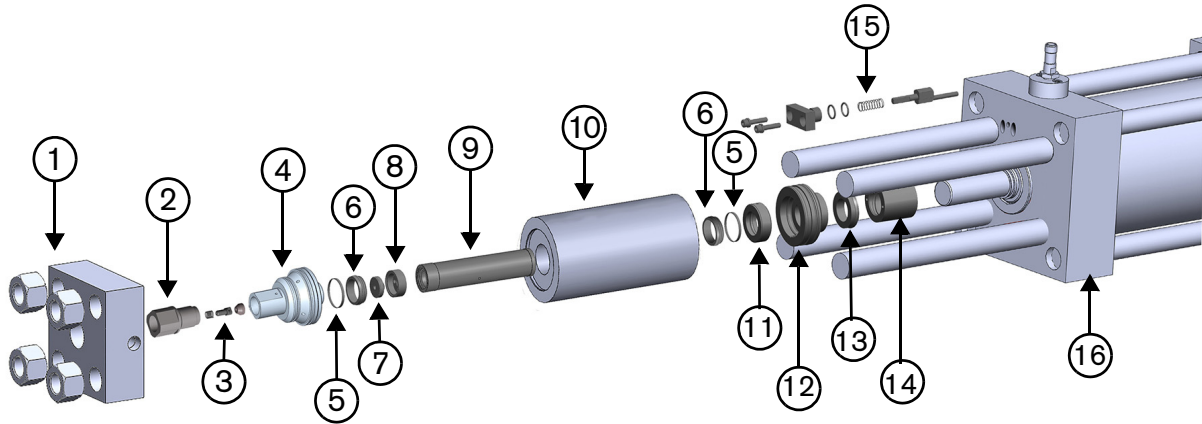

Preventive maintenance on the intensifier involves accessing various assemblies at specified intervals. To reduce downtime, Hypertherm recommends doing preventive maintenance on both ends of the intensifier at the same time.



- 1 High-pressure end cap and stud nuts
- 2 Output adapter
- 3 High-pressure poppet assembly
- 4 Check valve assembly
- 5 High-pressure hoops
- 6 High-pressure water seals
- 7 Low-pressure poppet
- 8 Low-pressure poppet basket

- 9 Spacer tube
- 10 High-pressure cylinder
- 11 High-pressure seal backup
- 12 Seal housing
- 13 Hydraulic rod seal
- 14 Plunger bearing
- 15 Indicator pin assembly
- 16 Hydraulic end cap

Prepare to service the intensifier

 <p>WARNING</p>	<p>Working on this equipment while it is energized can cause a potentially hazardous situation, which, if not avoided, can cause serious injuries or death.</p> <p>Use a lock out–tag out program whenever workers engage in service or maintenance operations on machines that are capable of exposing them to hazardous energy from unexpected energization, startup, or release of stored energy. This energy can be from electrical, hydraulic fluid, or water sources.</p> <p>Before doing a service or maintenance, the following steps must be done in sequence.</p> <ol style="list-style-type: none"> 1. Turn off the machine. 2. Disconnect or isolate the machine from the energy source(s). Refer to the specific provisions of the employer’s energy-control procedure. 3. Apply the lock-out and tag-out devices to the energy-isolating device(s). 4. Release, restrain, or otherwise render safe all potential hazardous stored or residual energy. If a possibility exists for reaccumulation of hazardous energy, regularly verify that such energy has not reaccumulated to hazardous levels. 5. Verify the isolation and deenergization of the machine.
 <p>CAUTION</p>	<p>Overtightening a fitting can cause it to fail. Use 2 wrenches when loosening or tightening a high-pressure connection. Using only 1 wrench can increase bending stress to the parts and cause damage or premature failure.</p>
	<p>Do not use an adjustable wrench on high-pressure fittings.</p>
	<p>Use clean hands when changing high-pressure parts such as high-pressure water seals.</p>

 Consider doing preventive maintenance on both high-pressure ends to reduce unplanned downtime.

Required parts, tools, and materials

- 13/16-inch open-ended wrench or socket (high-pressure water fitting)
- 7/8-inch open-ended wrench (low-pressure water fitting)
- 1-inch open-ended wrench (output adapter)
- 1-1/6-inch open-ended wrench (high-pressure water fitting)

Do this task when the pump is running in cooling mode.

5 – Preventive maintenance

1. Touch the symbol on the operator interface to open the maintenance screen.
2. Touch the pump maintenance symbol to open the intensifier maintenance screen.

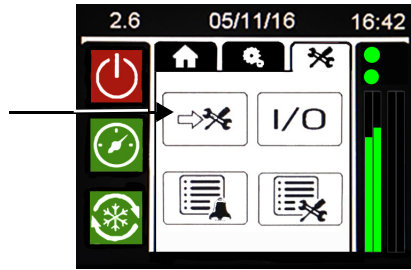

3. Touch the applicable symbol to move the intensifier to the left or to the right. Doing maintenance on a high-pressure end is much easier when the plunger is moved to that end.

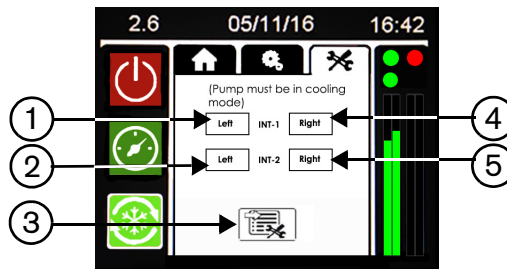

- 1 Move the front intensifier to the left
- 2 Move the rear intensifier to the left
- 3 Open the maintenance logging screen
(Refer to page 62.)
- 4 Move the front intensifier to the right
- 5 Move the rear intensifier to the right



The pump must be in cooling mode to use this feature.



Pumps without a redundant intensifier do not have the option to move the rear intensifier.

4. Turn OFF the pump.
5. Turn OFF power from the primary utility source. Use standard lock out–tag out procedures. Refer to page 97 for more information.
6. Turn OFF the water to the pump.

5 – Preventive maintenance

7. Open the water valve to drain the water from the system. Make sure that the water pressure gauges show 0.0 bar or 0 kPa (0 psi).

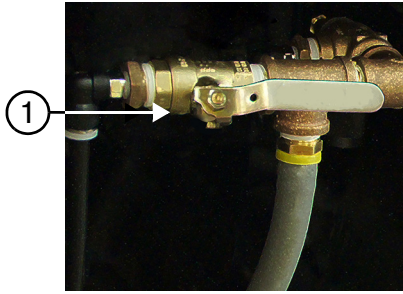

1 Water valve in the open position

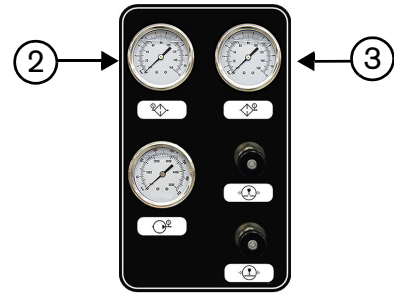

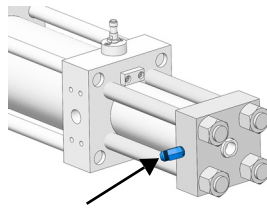

2 Prefilter water pressure
3 Postfilter water pressure

8. Disconnect the high-pressure water line from the intensifier.
9. Disconnect the hose from the low-pressure water fitting on the high-pressure end cap.



5 – Preventive maintenance

Disassemble the intensifier

	Repair or replace parts identified in the preventive maintenance schedule or if the parts show deterioration, corrosion, or damage.
	Examine parts that are being replaced to identify wear patterns or damage that can indicate other problems

 Refer to the **Intensifier parts** section on page 127 for part numbers. Refer to page 149 for ordering information.

Remove the output adapter and the high-pressure poppet assembly

	If any of the poppet parts are damaged, replace all 3.
---	--

Service	Interval
Replace the high-pressure poppet assemblies	After every 1,000 hours of operation
Replace the output adapters	After every 6,000 hours of operation

 The high-pressure poppet seat can cause cracks, erosion marks, or indents in the output adapter.

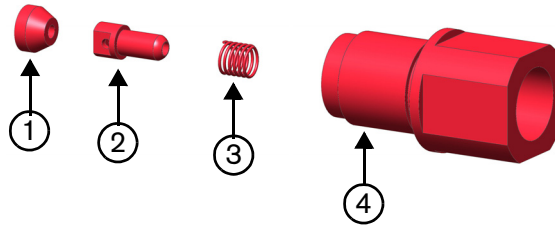

- 1 High-pressure poppet seat
- 2 High-pressure poppet

- 3 High-pressure poppet spring
- 4 Output adapter



Required parts, tools, and materials

Clean, lint-free towels

Isopropyl alcohol

1-inch open-ended wrench

15564 6-inch cotton-tipped applicator

1. Use an open-ended wrench to loosen the output adapter. Remove the output adapter from the check valve.
2. Use a cotton-tipped applicator to guide the high-pressure poppet seat out of the check valve. Tap the output adapter gently on a wooden or other soft surface to eject the poppet from the output adapter.
3. Clean each part with a lint-free towel and isopropyl alcohol. Examine all parts for deterioration, corrosion, or damage.

	Do not use soap, detergent, or solvents.
---	--

5 – Preventive maintenance

Remove the high-pressure end cap

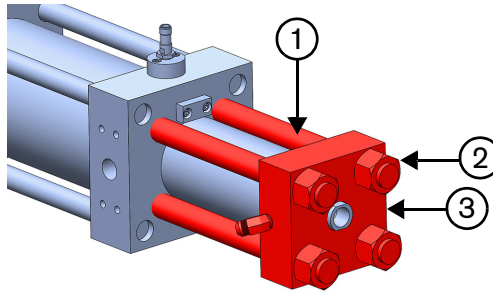

1 Studs

2 Stud nuts

3 High-pressure end cap



Required parts, tools, and materials

Clean, lint-free towels

Isopropyl alcohol

Square drive socket, 1-1/2 inch × 3/4 inch (included in the 12084 HyPrecision standard tool kit)

1. Remove the stud nuts.
2. Pull the high-pressure end cap off.
3. Clean each part with a lint-free towel and isopropyl alcohol. Examine all parts for deterioration, corrosion, or damage.



Do not use soap, detergent, or solvents.

5 – Preventive maintenance

Remove the high-pressure cylinder assembly and the check valve

Service	Interval
Repair the check valves and the low-pressure poppets (page 107)	After every 500 hours of operation
Repair the high-pressure cylinders (page 109)	
Replace the check valve O-rings	
Replace the high-pressure hoops	
Replace the high-pressure water seals	
Replace the low-pressure poppets	After every 1,000 hours of operation
Replace the check valves	After every 2,000 hours of operation
Replace the low-pressure poppet baskets	
Replace the high-pressure cylinders	After every 3,000 hours of operation or if the cylinder is chipped or cracked
Replace the spacer tubes	After every 12,000 hours of operation

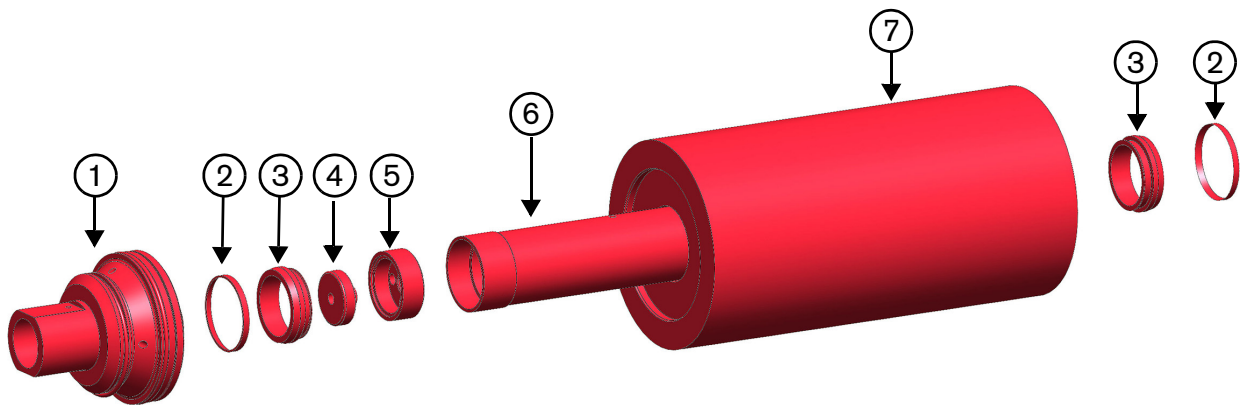

- | | |
|-----------------------------|------------------------------|
| 1 Check valve | 5 Low-pressure poppet basket |
| 2 High-pressure hoops | 6 Spacer tube |
| 3 High-pressure water seals | 7 High-pressure cylinder |
| 4 Low-pressure poppet | |



Required parts, tools, and materials

Clean, lint-free towels

Isopropyl alcohol

Seal installation tools (included in the HyPrecision standard tool kit; refer to **Tools** on page 74)

Rubber mallet

5 – Preventive maintenance

1. Remove the high-pressure cylinder and the check valve from the plunger.
2. Remove the check valve by rolling the cylinder and tapping the check valve with a rubber mallet. Tap at an angle away from the cylinder.
3. Tilt the cylinder so that the low-pressure poppet comes out.
4. Put the cylinder on the seal-locating ring.
5. Put the stepped end of the push tool against the seal and tap on the end of the push tool with a rubber mallet to push the bottom seal and the hoop out of the high-pressure cylinder.
6. Turn the cylinder over and put it on the locating ring.



Prevent the spacer tube from sliding out when the cylinder is turned over.

7. Put the nonstepped end of the push tool against the spacer tube and tap on the end of the push tool with a rubber mallet to push the seal and the hoop out of the high-pressure cylinder.
8. Slide the spacer tube out of the cylinder.
9. Disassemble all of the parts.
10. Clean each part with a lint-free towel and isopropyl alcohol. Examine all parts for deterioration, corrosion, or damage.



Do not use soap, detergent, or solvents.

5 – Preventive maintenance

Remove the seal housing assembly and the plunger bearing

Service	Interval
Replace the high-pressure seal backups	After every 500 hours of operation
Replace the hydraulic rod seals	
Replace the seal housing O-rings	
Replace the seal housing O-ring backups	
Replace the plunger bearings	After every 3,000 hours of operation or when replacing the high-pressure cylinder
Replace the seal housings	After every 6,000 hours of operation

 Remove the proximity switch from the hydraulic end cap to make this procedure easier.

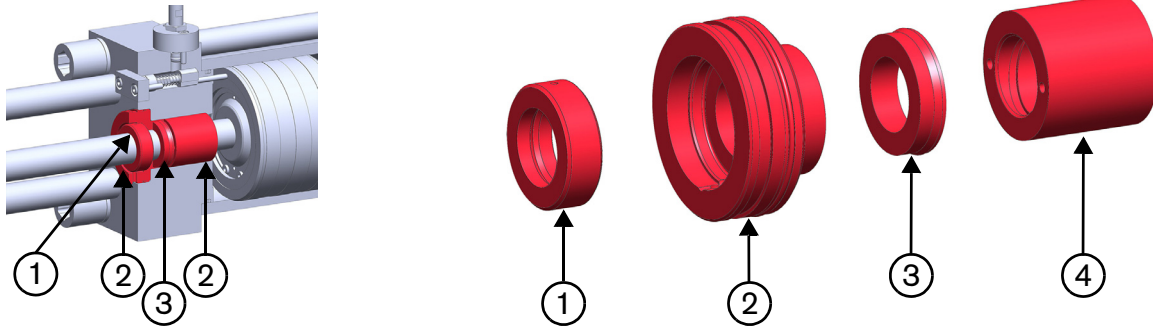

- 1 High-pressure seal backup
- 2 Seal housing

- 3 Hydraulic rod seal
- 4 Plunger bearing



Required parts, tools, and materials

Clean, lint-free towels

Isopropyl alcohol

Seal housing removal tool (included in the HyPrecision standard tool kit; refer to **Tools** on page 74)

1/8-inch hex wrench (seal housing removal tool)

Two 8-32 × 2-inch (or longer) socket-head cap screws (plunger bearing)

Recommended materials

Dental pick (or similar tool)

5 – Preventive maintenance

1. Slide the seal housing removal tool into the groove on the seal housing.

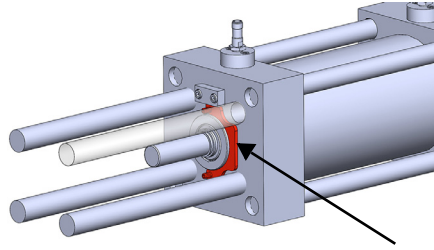

2. Use a hex wrench to turn the screws on the seal housing removal tool.

 Alternate sides so that the tool pulls the housing straight out of the hydraulic end cap.

3. Pull the seal housing and the high-pressure seal backup off the plunger.

 If the rod seal does not come out of the hydraulic end cap with the seal housing, use a dental pick or a similar tool to pry it out. Be careful to not scratch the plunger.

4. Remove the high-pressure seal backup and the O-ring from the seal housing.

5. Install 2 socket-head cap screws in the threaded holes in the plunger bearing. Use the screws to pull the plunger bearing out of the hydraulic end cap.

6. Remove the plunger bearing from the plunger.

7. Clean each part with a lint-free towel and isopropyl alcohol. Examine all parts for deterioration, corrosion, or damage.



Do not use soap, detergent, or solvents.

5 – Preventive maintenance

Remove the indicator pin assembly

Service	Interval
Replace the indicator pin spring	After every 3,000 hours of operation
Replace the indicator pin	After every 6,000 hours of operation

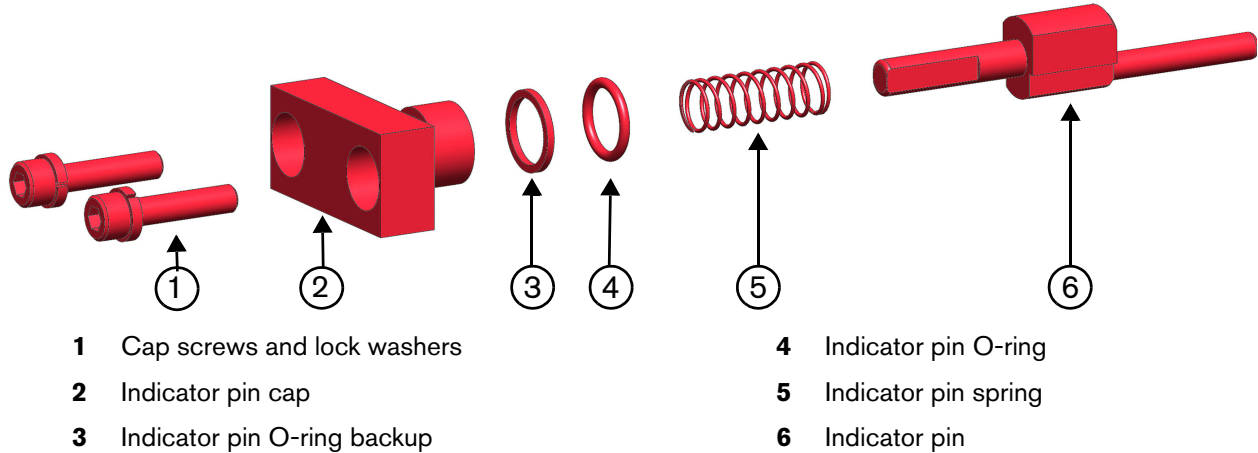

Required parts, tools, and materials

- Clean, lint-free towels
- Isopropyl alcohol
- 5/32-inch hex wrench

1. Use a hex wrench to remove the socket-head cap screws and the lock washers from the indicator pin cap.
2. Pull the indicator pin cap out of the hydraulic end cap.
3. If the O-ring backup and the O-ring are being replaced, remove them from the indicator pin cap.
4. Remove the spring from the indicator pin.
5. Remove the indicator pin from the indicator pin hole in the hydraulic end cap.
6. Clean each part with a lint-free towel and isopropyl alcohol. Examine all parts for deterioration, corrosion, or damage.



Do not use soap, detergent, or solvents.

5 – Preventive maintenance

Repair the check valves and the low-pressure poppets

Service	Interval
Repair the check valves and the low-pressure poppets	After every 500 hours of operation

This procedure is for a moderately worn check valve. Severe wear requires replacement.

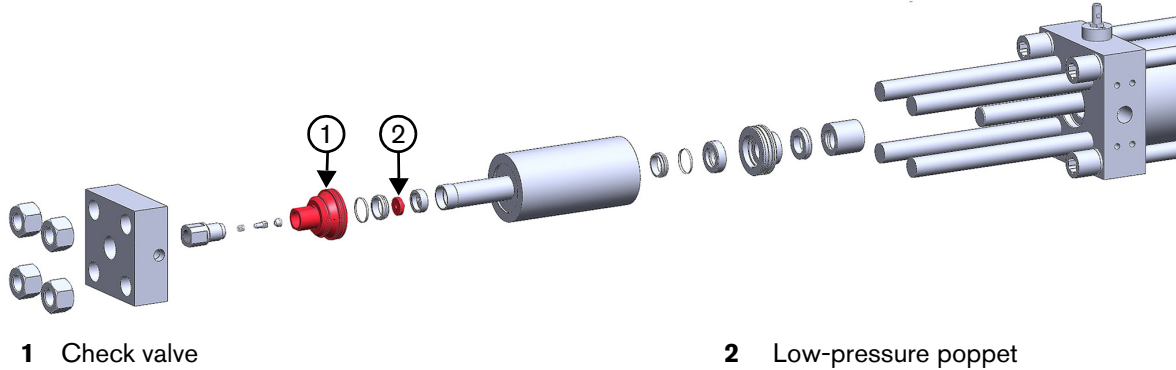

Required parts, tools, and materials

12-micron lapping paper (included in the 12084 HyPrecision standard tool kit)

15-micron lapping paper (included in the 12084 HyPrecision standard tool kit)

Granite surface plate (included in the 12084 HyPrecision standard tool kit)

Clean, lint-free towels

Isopropyl alcohol

Masking tape

1. Tape a sheet of lapping paper on a granite surface block. Make sure that the paper is smooth and flat.



For best results, start with the 12-micron lapping paper and finish with the 15-micron lapping paper.

2. Put the check valve or poppet face flat on the lapping paper and slide it back and forth. Apply light pressure.



CAUTION

Rocking the part or using too much pressure can damage the part face.

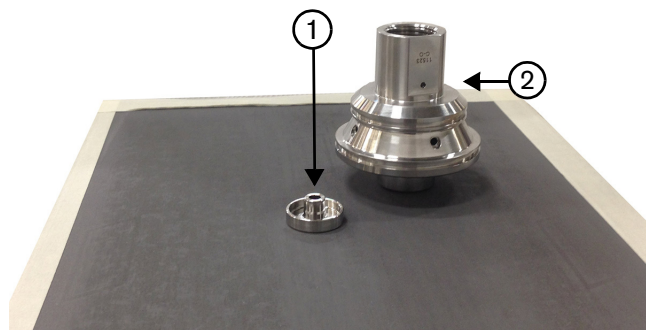

5 – Preventive maintenance

3. After each stroke, rotate the flat face of the part 45 degrees.
4. Repeat this procedure until the face is smooth and flat and has a nearly mirrored finish.
5. Clean each part with a lint-free towel and isopropyl alcohol.



Do not use soap, detergent, or solvents.

5 – Preventive maintenance

Repair the high-pressure cylinders

Service	Interval
Repair the high-pressure cylinders	After every 3,000 hours of operation or if the cylinder is chipped or cracked

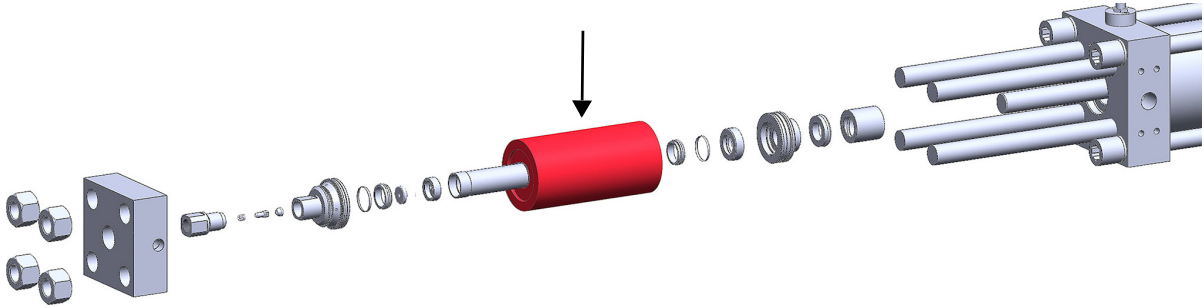

Required parts, tools, and materials

- 11210-30 30-micron lapping paper
- Clean, lint-free towels
- Nonstick scouring pad
- Isopropyl alcohol
- Emery cloth (no coarser than 120 grit)

1. Put the cylinder on a flat surface.
2. Examine the end of the cylinder. If the area outside of the bore is marked or pitted, rub the defects with emery cloth and then with a nonstick scouring pad.
3. Examine the edges of the cylinder bore. If the bore has rough edges or burrs, rub the defects with an emery cloth.
4. Cut the nonstick scouring pad in half. Put half of the pad in each end of the cylinder. Put 1 thumb in each end of the cylinder on top of the pad and push down. Push evenly on the pad while rolling the cylinder forward and backward.

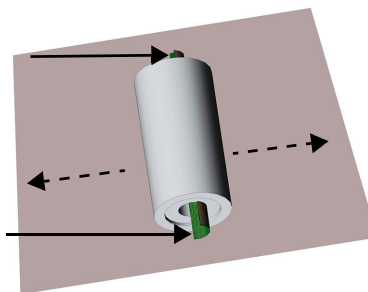



Nonstick scouring pad





5. Fold or cut the lapping paper to make 2 pieces, each approximately 3 cm (1-1/4 inches) wide by 8 cm (3-1/4 inches) long.

5 – Preventive maintenance

6. Put the lapping paper into the ends of the cylinder with the abrasive side touching the cylinder.
7. Repeat the rolling procedure with the lapping paper.
8. Clean the inside of the cylinder with a lint-free towel and isopropyl alcohol.

 CAUTION	Debris left in the cylinder can cause the seals or the poppets to fail.
	Do not use soap, detergent, or solvents.

Assemble the intensifier

 CAUTION	Overtightening a fitting can cause it to fail. Use 2 wrenches when loosening or tightening a high-pressure connection. Using only 1 wrench can increase bending stress to the parts and cause damage or premature failure.
	Review the Safety section, which begins on page 70.
	Examine parts that are being replaced to identify wear patterns or damage that can indicate other problems
	Put the parts on a clean, dry, oil-free surface.
	Use clean hands when changing high-pressure parts such as high-pressure water seals.

 Refer to the **Intensifier parts** section on page 127 for part numbers. Refer to page 149 for ordering information.

Repair the hydraulic center section

Service	Interval
Repair the hydraulic center section	After every 12,000 hours of operation

The hydraulic center section includes the pistons, the plungers, the hydraulic cylinder, the hydraulic end caps, the low-pressure seals, and the proximity switches.

Preventive maintenance on these parts requires special tools. Contact a Hypertherm Technical Service Associate for information and support regarding the installation, operation, maintenance, and repair of this equipment.

5 – Preventive maintenance

Install the indicator pin assembly

Service	Interval
Replace the indicator pin spring	After every 3,000 hours of operation
Replace the indicator pin	After every 6,000 hours of operation

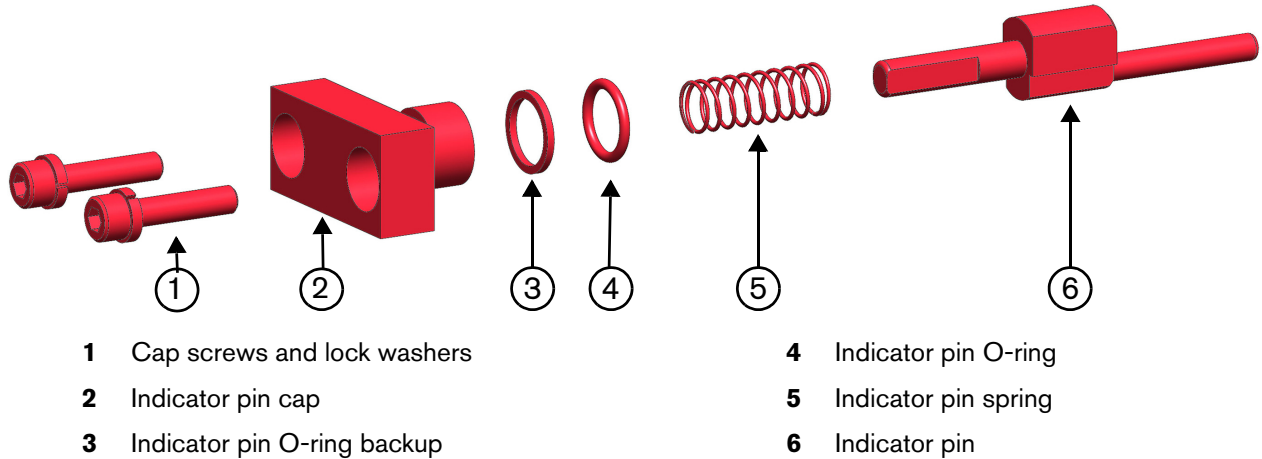

Required parts, tools, and materials

11518 Indicator pin

11669 Indicator pin spring (included in the 15569 HyPrecision S-series standard spares kit)

13186 Antiseize bolt lubricant (white lithium grease)

Antiwear (AW) mineral oil or synthetic hydraulic fluid, ISO viscosity grade (VG) 32 or 46

Torque wrench

5/32-inch hex wrench or hex-bit socket

1. Put the indicator pin into the indicator pin hole in the hydraulic end cap. Turn the pin so that the offset post goes into the aperture at the back of the hole.

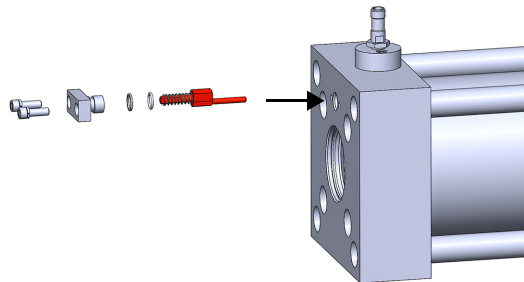

2. Put the spring on the indicator pin.
3. Put the O-ring backup on the indicator pin cap.
4. Put a small quantity of hydraulic fluid on the O-ring.
5. Put the O-ring on the indicator pin cap.

5 – Preventive maintenance

6. Put the indicator pin cap into the hydraulic end cap.
7. Put antiseize bolt lubricant (white lithium grease) on the cap screws.
8. Put the lock washers on the cap screws. Torque the cap screws to 10 N·m (8 lbf·ft).

5 – Preventive maintenance

Install the seal housing assembly and the plunger bearing



Water can enter the hydraulic system if the weep holes in the dynamic seal backup or the seal housing are blocked. Make sure that the weep holes are free of debris while doing maintenance on the intensifier.

Service	Interval
Replace the high-pressure seal backups	After every 500 hours of operation
Replace the hydraulic rod seals	
Replace the seal housing O-rings	
Replace the seal housing O-ring backups	
Replace the plunger bearings	After every 3,000 hours of operation or when replacing the high-pressure cylinder
Replace the seal housings	After every 6,000 hours of operation

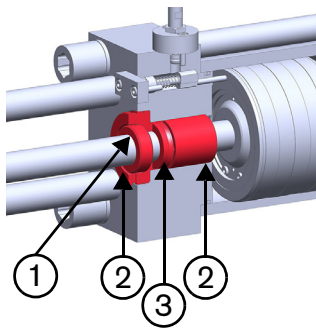

- 1 High-pressure seal backup
- 2 Seal housing

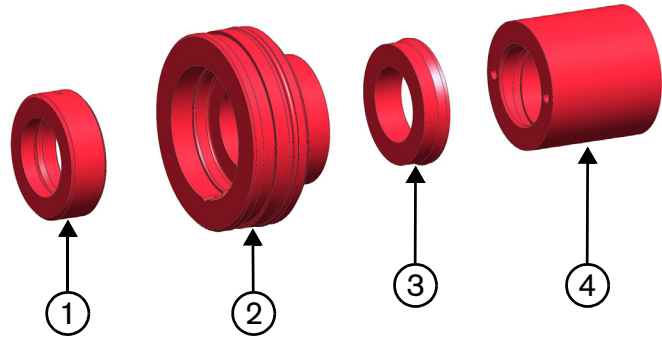

- 3 Hydraulic rod seal
- 4 Plunger bearing



Required parts, tools, and materials

- 15563 HyPrecision premium high-pressure seal repair kit
- 11608 Plunger bearing
- 11609 Seal housing
- 13969 Petroleum-based O-ring lubricant
- Antiwear (AW) mineral oil or synthetic hydraulic fluid, ISO viscosity grade (VG) 32 or 46

5 – Preventive maintenance

1. Examine the seal housing and the high-pressure seal backup. Make sure that the weep holes and the inside grooves are clean.

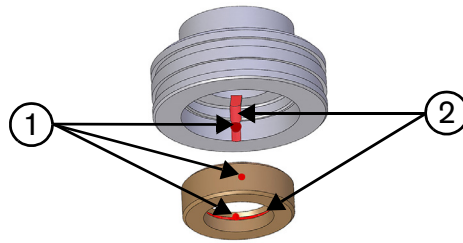

1 Weep holes

2 Grooves

2. Put O-ring lubricant on the backup ring and the seal housing O-ring.
3. Put the seal housing O-ring backup and the seal housing O-ring on the seal housing. Put the O-ring on the side nearer the narrow end of the seal housing.

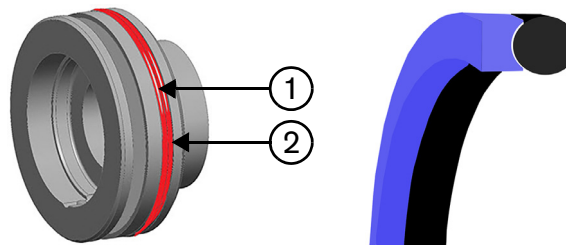

1 O-ring backup

2 O-ring

 The seal housing O-ring backup has a flat side and a concave side. Make sure the flat side of the O-ring backup faces the wide end of the seal housing. The O-ring fits into the concave groove on the O-ring backup.

4. Put the plunger bearing on the plunger and push it into the hydraulic end cap.

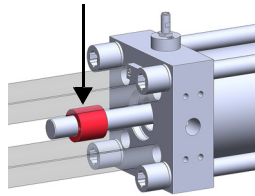

5. Put a small quantity of clean hydraulic fluid on the inside and the outside of the rod seal.
6. Put the rod seal onto the plunger with the wider side toward the hydraulic end cap.



Do not push the rod seal into the hydraulic end cap.

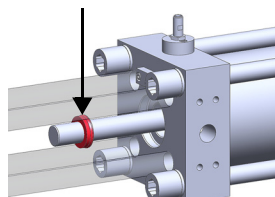

5 – Preventive maintenance

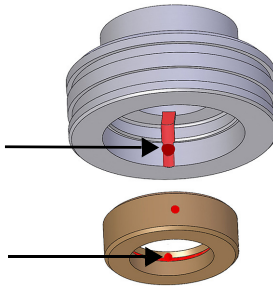

7. Put hydraulic fluid inside the narrow end of the seal housing.
8. Put the seal housing on the plunger with the narrow end toward the hydraulic end cap.
9. Push the rod seal into the seal housing.
10. Turn the seal housing so that the weep hole faces down.
11. Push the seal housing tightly against the plunger bearing.
12. Turn the high-pressure seal backup so that 1 weep hole is in line with the seal housing weep hole.
13. Put the high-pressure seal backup on the plunger and push it against the seal housing.
14. Make sure that the bottom weep holes are aligned.



15. If the proximity switch was removed for this procedure, reinstall it.

5 – Preventive maintenance

Install the high-pressure hoops, the high-pressure water seals, the high-pressure cylinders, and the check valves

	Do not put grease or lubricant on the check valve face or in the cylinder bore. These are designed for dry contact.
	Install a new plunger bearing when replacing the high-pressure cylinder.

Service	Interval
Repair the check valves and the low-pressure poppets (page 107)	After every 500 hours of operation
Repair the high-pressure cylinders (page 109)	
Replace the check valve O-rings	
Replace the high-pressure hoops	
Replace the high-pressure water seals	
Replace the low-pressure poppets	After every 1,000 hours of operation
Replace the check valves	After every 2,000 hours of operation
Replace the low-pressure poppet baskets	
Replace the high-pressure cylinders	After every 3,000 hours of operation or if the cylinder is chipped or cracked
Replace the spacer tubes	After every 12,000 hours of operation

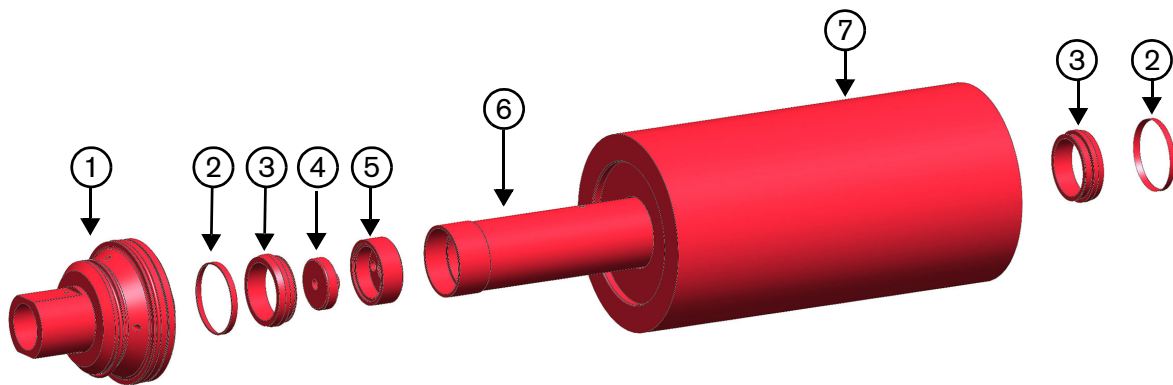

- | | |
|-----------------------------|------------------------------|
| 1 Check valve | 5 Low-pressure poppet basket |
| 2 High-pressure hoops | 6 Spacer tube |
| 3 High-pressure water seals | 7 High-pressure cylinder |
| 4 Low-pressure poppet | |

5 – Preventive maintenance



Required parts, tools, and materials

15563 HyPrecision premium high-pressure seal repair kit

15568 HyPrecision S- and D-series poppet repair kit

11523 Check valve assembly

11520 Low-pressure poppet basket

11521 Spacer tube

11522 High-pressure cylinder

High-pressure antiseize lubricant such as Blue Goop or AccuGoop

Seal installation tools (refer to **Tools** on page 74)

Rubber mallet

1. Put the seal installation spacer tool on a clean, dry, oil-free surface.
2. Put the high-pressure cylinder over the spacer tool so that the tool fits in the cylinder bore.



3. Put the low-pressure poppet into the low-pressure poppet basket.



Keep the poppet and the poppet basket clean. Grease can cause the poppet to stick.

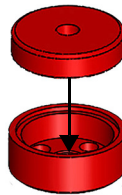

Make sure that the poppet moves freely.

5 – Preventive maintenance

4. Put the low-pressure poppet basket with the low-pressure poppet into the spacer tube.



Keep the poppet and the poppet basket clean. Grease can cause the poppet to stick.



5. Put the spacer tube into the high-pressure cylinder.

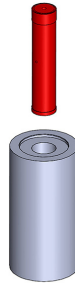

6. Put the seal installation locator tool on top of the cylinder.



7. Put the seal installation sleeve in the locator tool with the flat opening toward the cylinder.



The beveled opening faces up.

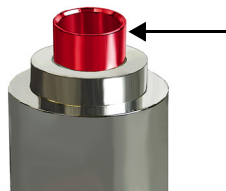

8. Put a small quantity of high-vacuum grease on the red O-ring.

5 – Preventive maintenance

9. Put the red O-ring into the groove on the high-pressure water seal.

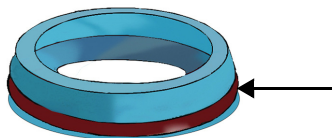

10. Put the high-pressure water seal into the insertion sleeve with the red O-ring toward the cylinder.



11. Put the push tool into the insertion sleeve with the stepped end up. Apply even pressure while holding the sleeve tightly against the cylinder.

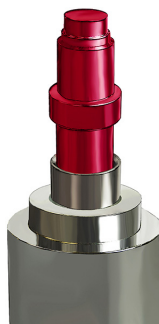

12. Remove the push tool from the insertion sleeve.
13. Make sure that the seal is installed in the cylinder correctly.

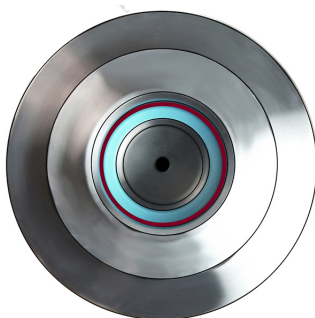

5 – Preventive maintenance

14. Put the hoop into the insertion sleeve with the sharp edge toward the cylinder.

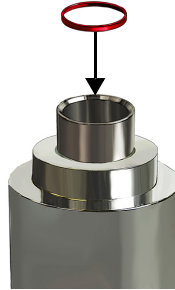

15. Put the push tool into the insertion sleeve with the stepped end up. Tap the push tool sleeve with a rubber mallet until the push tool contacts the sleeve.

 Hold the sleeve tightly in the cylinder while tapping the push tool.

16. Remove the seal insertion push tool, the sleeve, and the locator.
17. Make sure that the hoop edges are even with the surface of the cylinder. If the edges are not even with the surface of the cylinder, put the nonstepped end of the push tool on the hoop and tap the push tool with a rubber mallet.

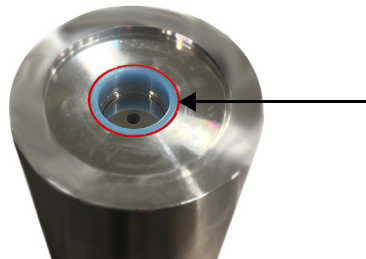

18. Put the end of the check valve into the seal. Tap on the small end of the check valve with a rubber mallet until it is touching the cylinder end.

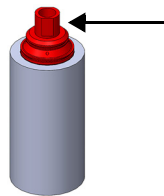

19. Turn the cylinder over so the check valve is on the bottom. Put 1 hand under the bore at the bottom of the cylinder to catch the spacer tool and to prevent the spacer tube from sliding out.
20. Use the same procedure to install the second seal and the hoop in the high-pressure cylinder.
21. Slide the cylinder and the check valve on to the plunger by pushing on the end of the check valve until the cylinder is touching the seal housing.

5 – Preventive maintenance

Install the high-pressure end caps



Overtightening a fitting can cause it to fail. Use 2 wrenches when loosening or tightening a high-pressure connection. Using only 1 wrench can increase bending stress to the parts and cause damage or premature failure.

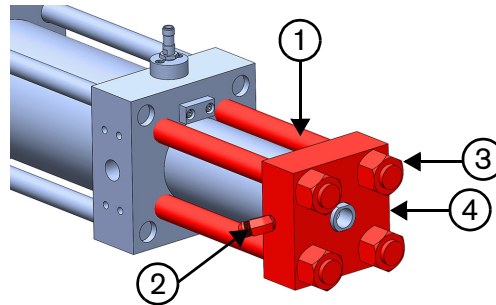

- | | |
|------------------------------|-------------------------|
| 1 Studs | 3 Stud nuts |
| 2 Low-pressure water fitting | 4 High-pressure end cap |



Required parts, tools, and materials

13186 Antiseize bolt lubricant (white lithium grease)

High-pressure antiseize lubricant such as Blue Goop or AccuGoop

7/8-inch open-ended wrench

12091 Torque wrench, 3/4-inch drive, 60 lbf·ft to 300 lbf·ft (included in the 12084 HyPrecision standard tool kit)

Square drive socket, 1-1/2 inch × 3/4 inch (included in the 12084 HyPrecision standard tool kit)

5 – Preventive maintenance

1. Put the high-pressure end cap onto the check valve and the studs with the water fitting pointed toward the attenuator.
2. Put antiseize bolt lubricant (white lithium grease) on the stud threads.
3. Hand tighten the nuts on the studs.



Put the smooth side of the nut toward the high-pressure end cap.

4. Torque the stud nuts to 373 N·m (275 lbf·ft).



Tighten each nut in 68 N·m (50 lbf·ft) increments using a repeating cross pattern until the recommended torque is reached.

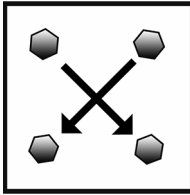

5. Connect the low-pressure water line.
6. Torque the low-pressure water fitting to 31 N·m to 41 N·m (25 lbf·ft to 30 lbf·ft).

5 – Preventive maintenance

Install the output adapter and the high-pressure poppet assembly



Overtightening a fitting can cause it to fail. Use 2 wrenches when loosening or tightening a high-pressure connection. Using only 1 wrench can increase bending stress to the parts and cause damage or premature failure.

Service	Interval
Replace the high-pressure poppet assemblies	After every 1,000 hours of operation
Replace the output adapters	After every 6,000 hours of operation

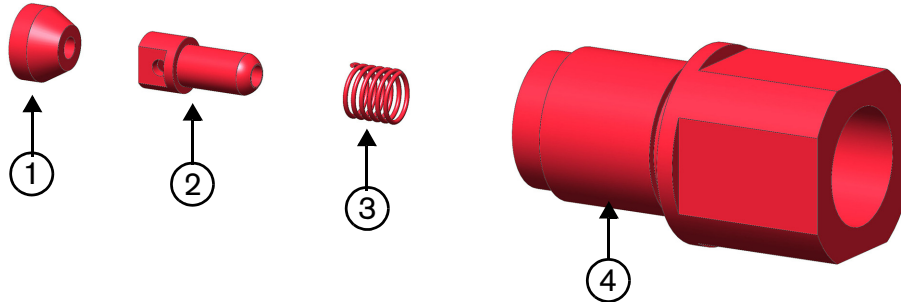

- 1 High-pressure poppet seat
- 2 High-pressure poppet

- 3 High-pressure poppet spring
- 4 Output adapter



Required parts, tools, and materials

15563 HyPrecision premium high-pressure seal repair kit

15568 HyPrecision S- and D-series poppet repair kit

11530 Output adapter

High-pressure antiseize lubricant such as Blue Goop or AccuGoop

1-inch crowfoot wrench or socket

13/16-inch open-ended wrench or socket

Torque wrench

5 – Preventive maintenance

1. Put O-ring lubricant on the O-rings. Put the O-rings on the check valve.
2. Use a cotton-tipped applicator to put high-pressure antiseize lubricant in the recess in the bottom of the check valve.



3. Use a cotton-tipped applicator to guide the high-pressure poppet seat into the check valve. The wide end of the poppet seat faces toward the check valve.

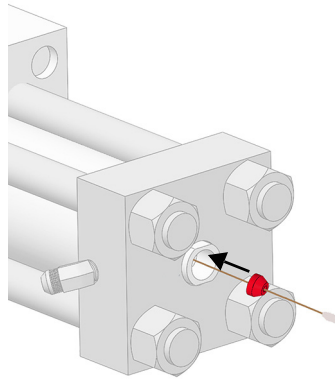

4. Push the poppet seat into the high-pressure antiseize lubricant in the check valve.
5. Put high-pressure antiseize lubricant on the threads of the output adapter.

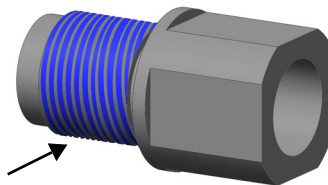

6. Put the high-pressure poppet spring and the high-pressure poppet in the output adapter.
7. Put the output adapter in the check valve and tighten it by hand.



Tightening the output adapter with the poppet in an incorrect position can cause damage. When the output adapter is properly installed, the gap between the wide part of the output adapter and the check valve is 10 mm (3/8 inch) and no threads are visible. If the gap is larger or threads are visible, make sure that the poppet parts have not moved.

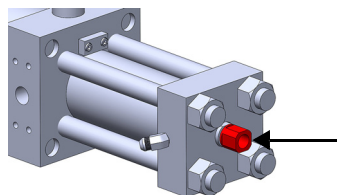

8. Torque the output adapter to 41 N·m to 47 N·m (30 lbf·ft to 35 lbf·ft).

5 – Preventive maintenance

9. Put high-pressure antiseize lubricant on the high-pressure connector threads.

10. Connect the high-pressure water line.



Make sure that a few of the threads on the high-pressure tubing are visible.

11. Torque the high-pressure water fitting to 41 N·m to 47 N·m (30 lbf·ft to 35 lbf·ft).

5 – Preventive maintenance

Intensifier parts

15569 HyPrecision S-series standard spares kit

Part number	Description	Quantity
11669	Indicator pin spring	2
11679-013	Indicator pin O-ring, -013	2
11680-013	Indicator pin O-ring backup -013	2
15563	HyPrecision premium high-pressure seal repair kit	2
15568	HyPrecision poppet repair kit	2
12981	Bleed-down valve II repair kit	1
16025	Hydraulic filter	1
11105	Water filter cartridge, 0.45 micron, 10 inch	1
11106	Water filter cartridge, 1.0 micron, 10 inch	1
11107	Water filter cartridge, 10 micron, 10 inch	1
15564	6-inch cotton-tipped applicator	2

15563 HyPrecision premium high-pressure seal repair kit

Part number	Description	Quantity
11610	High-pressure seal backup (bronze)	2
11090	Hydraulic rod seal, 1 inch	2
11680-035	Seal housing O-ring backup, -035	2
11679-035	Seal housing O-ring, -035	2
11018	High-pressure hoop, 1 inch	4
11024	High-pressure water seal, 1 inch	4
11679-035	Check valve O-ring, -035	2
11679-031	Check valve O-ring, -031	2
11447	High-vacuum grease, 5 oz.	1

15568 HyPrecision S- and D-series poppet repair kit

Part number	Description	Quantity
11526	Low-pressure poppet	2
11015	High-pressure poppet seat	2
11014	High-pressure poppet	2
11126	High-pressure poppet spring	2
15564	6-inch cotton-tipped applicators	2

5 – Preventive maintenance

Other parts

Part number	Description
11210-30	Lapping paper, 30 micron
11518	Indicator pin
11609	Seal housing
11608	Plunger bearing
11520	Low-pressure poppet basket
11523	Check valve assembly
11521	Spacer tube
11522	High-pressure cylinder
11530	Output adapter

High-pressure water system: Bleed-down valve

Examine the bleed-down valve for leaks or damage

 CAUTION	Failure to correct the cause of a leak can cause damage to the water fittings.
---	--

Service	Interval
Examine the bleed-down valve for leaks or damage	Every work shift

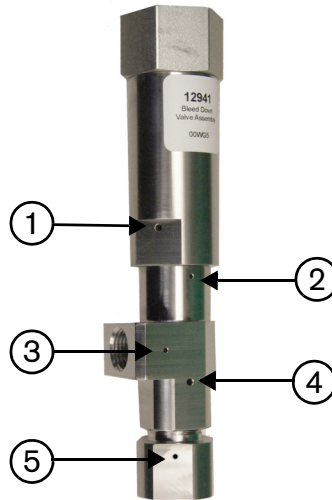



- | | |
|--|--|
| <ul style="list-style-type: none"> 1 O-ring 2 High-pressure seal 3 High-pressure water connection | <ul style="list-style-type: none"> 4 Poppet seat 5 Output connection |
|--|--|

 Weep hole 1 will leak hydraulic fluid. The others will leak water.

Do this task when the pump is running.

1. Remove the pump end panel.
2. Monitor for leaks. Identify the source of a leak and correct the problem. Refer to **Leaks** on page 163.

 WARNING	Do not attempt to repair a leak with pressure in the system.
 WARNING	Use a piece of cardboard or other solid material to check for leaks when the pump is on. Do not use hands, cloth, paper, or towels.

5 – Preventive maintenance

Repair the bleed-down valve

Service	Interval
Repair the bleed-down valve	After every 1,000 hours of operation or if water leaks from the wastewater outlet or from the weep holes while the pump is running

Refer to **Bleed-down valve parts** on page 143 for part numbers. Refer to page 149 for ordering information.

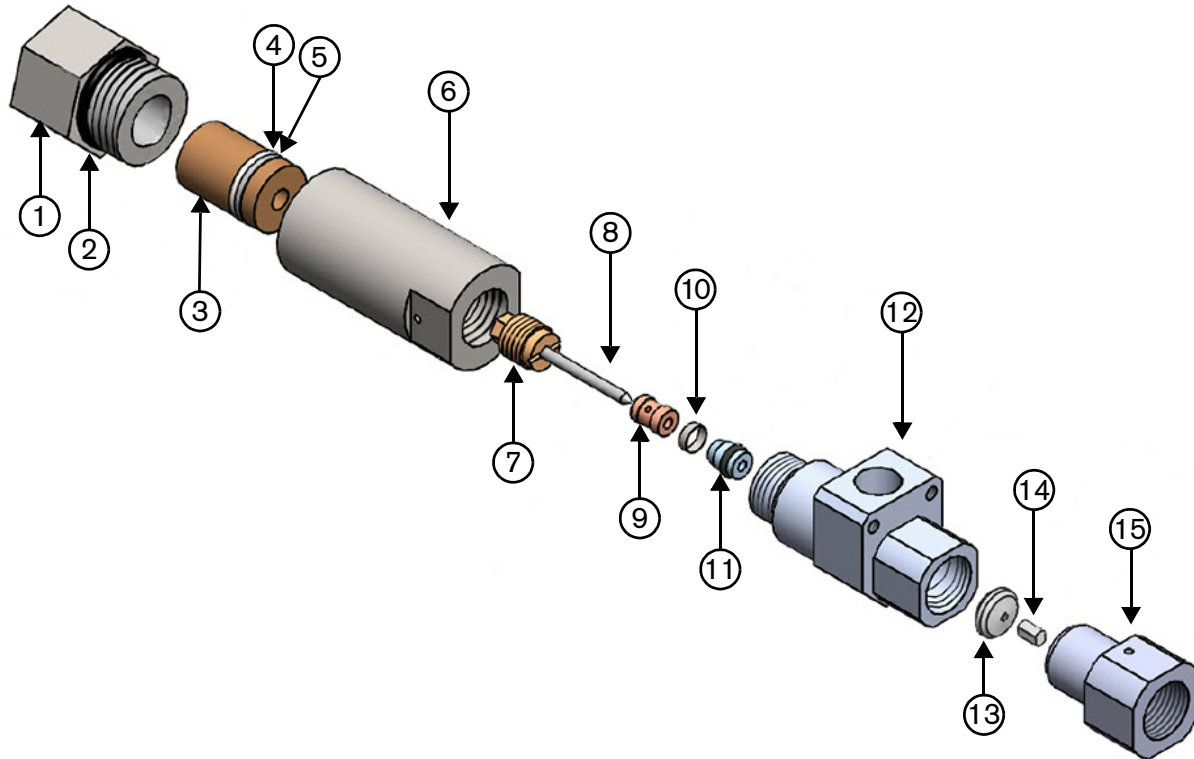

- | | | | |
|---|----------------------|----|---------------------------|
| 1 | O-ring boss adapter | 9 | Needle bushing |
| 2 | SAE O-ring | 10 | Seal hoop |
| 3 | Hydraulic piston | 11 | High-pressure seal |
| 4 | Piston O-ring | 12 | Valve body |
| 5 | Piston O-ring backup | 13 | High-pressure poppet seat |
| 6 | Actuator housing | 14 | Flow reducer |
| 7 | Seal backup screw | 15 | Outlet adapter |
| 8 | Needle | | |

5 – Preventive maintenance

Remove the bleed-down valve from the pump

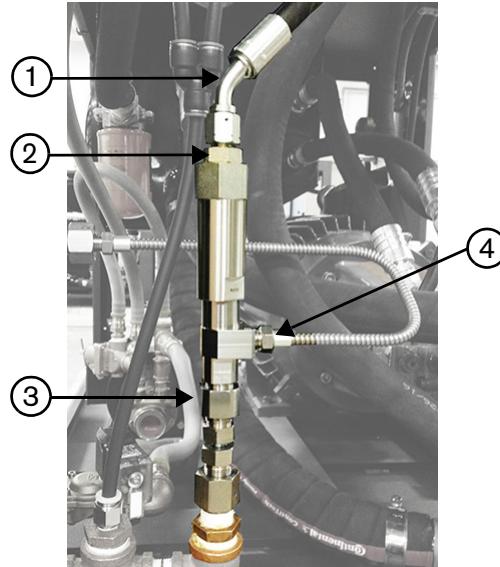

- | | | | |
|---|------------------------|---|---|
| 1 | Hydraulic hose | 3 | High-pressure water fitting (gland nut) |
| 2 | Hydraulic hose fitting | 4 | 3/8-inch gland nut |



Required parts, tools, and materials

Full set of standard open-ended wrenches

Adjustable wrench

Do this task when the pump is not running.

1. Turn OFF the water to the pump.
2. Open the water valve to drain the water from the system. Make sure that the water pressure gauges show 0.0 bar or 0 kPa (0 psi).

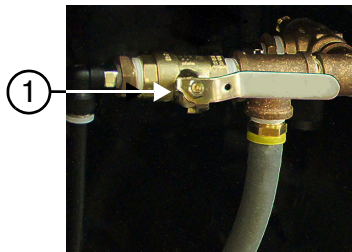

- 1 Water valve in the open position

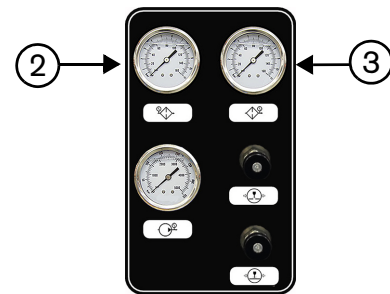

- 2 Prefilter water pressure
3 Postfilter water pressure

3. Use 2 wrenches to remove the hydraulic hose from the hydraulic hose fitting.
4. Use 2 wrenches to remove the high-pressure water fitting from the valve body.
5. Use 2 wrenches to remove the output adapter from the 3/8-inch gland nut.

5 – Preventive maintenance

Repair the bleed-down valve



Required parts, tools, and materials

12981 Bleed-down valve II repair kit

12943 Bleed-down valve body

13969 Petroleum-based O-ring lubricant

Full set of standard open-ended wrenches

Adjustable wrench

High-pressure antiseize lubricant such as Blue Goop or AccuGoop

Clean, lint-free towels

Isopropyl alcohol

Do this task when the pump is not running.

1. Use 2 wrenches to remove the O-ring boss adapter from the actuator housing.



2. Replace the SAE O-ring on the O-ring boss adapter.



Put O-ring lubricant on the O-ring.



The SAE O-ring and the piston O-ring look almost the same. The SAE O-ring is thinner than the hydraulic piston O-ring.



SAE O-ring



Hydraulic piston O-ring



3. Use 2 wrenches to remove the actuator housing from the valve body.

5 – Preventive maintenance

4. Use the wooden dowel from the bleed-down valve repair kit to push the hydraulic piston out of the actuator housing.

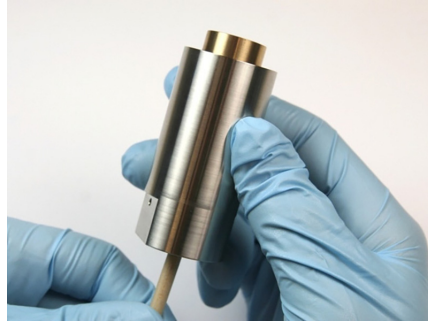

5. Remove the piston O-ring and the piston O-ring backup from the hydraulic piston.
6. Clean the hydraulic piston with a lint-free towel and isopropyl alcohol. Examine the hydraulic piston for deterioration, corrosion, or damage. Replace it if necessary.



Do not use soap, detergent, or solvents.

7. Put O-ring lubricant on the new piston O-ring backup. Roll the backup into the short end of the hydraulic piston. The piston O-ring backup has a flat side and a concave side. Make sure the flat side of the piston O-ring backup faces the short end of the hydraulic piston.

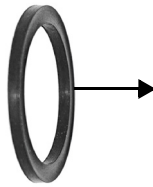

Concave side

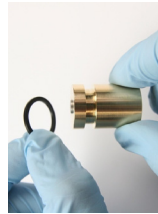

8. Put O-ring lubricant on the piston O-ring and roll it over the long end of the hydraulic piston. The piston O-ring fits into the concave groove on the piston O-ring backup.



The SAE O-ring and the piston O-ring look almost the same. The SAE O-ring is thinner than the hydraulic piston O-ring.



SAE O-ring



Hydraulic piston O-ring

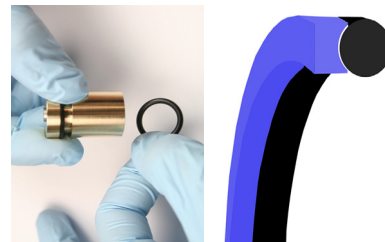

5 – Preventive maintenance

9. Put the hydraulic piston in the actuator housing.

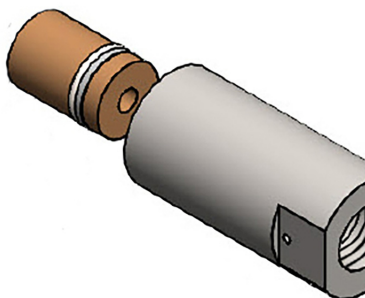

10. Push the hydraulic piston into position with a wooden dowel.

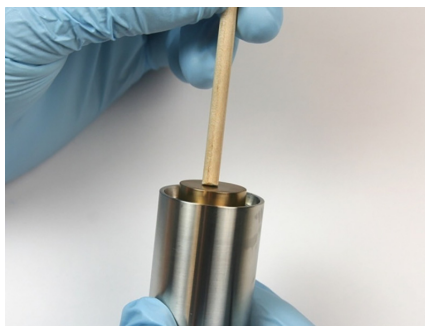

11. Use 2 wrenches to remove the outlet adapter from the valve body.

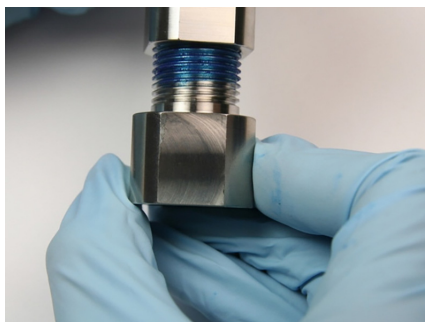

12. Remove the high-pressure poppet seat and the flow reducer from the outlet adapter.



5 – Preventive maintenance

13. Use a socket wrench to remove the seal backup screw from the valve body.



14. Use a wooden dowel to push the parts through the valve body.

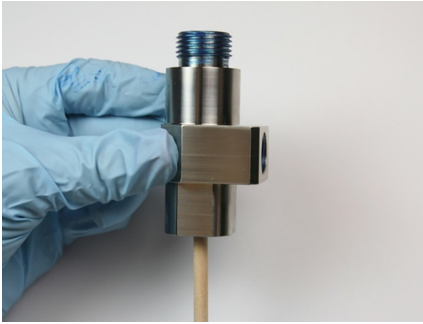

15. Clean each part with a lint-free towel and isopropyl alcohol. Examine all parts for deterioration, corrosion, or damage.



Do not use soap, detergent, or solvents.

16. Discard the used parts.
17. Put high-vacuum grease on the new needle.

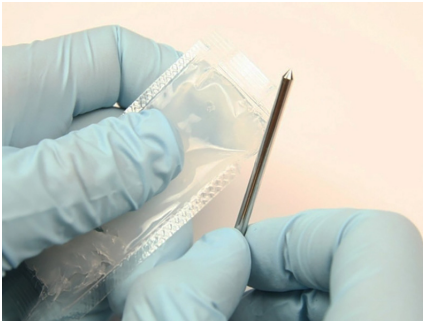

5 – Preventive maintenance

18. Put the seal backup screw on the needle. The flat end of the needle is flush with the hex end of the seal backup screw.



19. Put the needle bushing on the needle. The chamfered end of the needle bushing goes toward the seal backup screw.

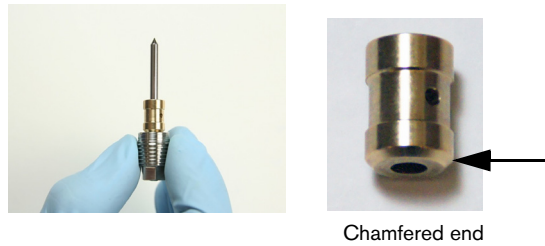

20. Put the seal hoop on the high-pressure seal. The tapered edge is toward the high-pressure seal.

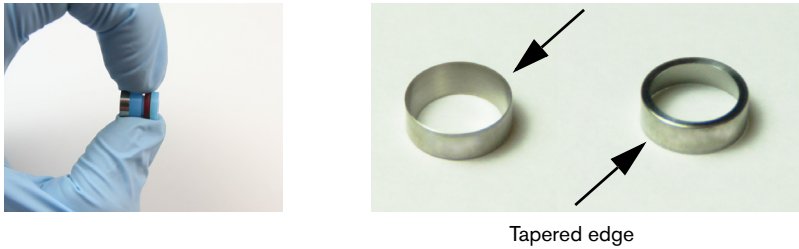

21. Put the high-pressure seal assembly on the needle. The hoop goes toward the needle bushing.



22. Put high-vacuum grease on the outside of the needle assembly.

5 – Preventive maintenance

23. Put the needle assembly in the valve body.



24. Push on the seal backup screw until it stops.

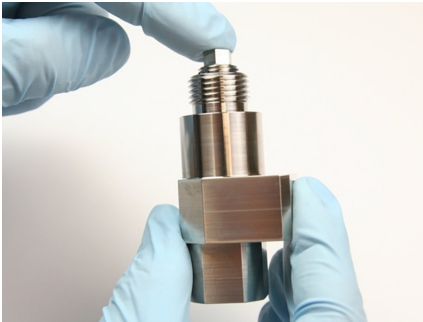

25. Remove the seal backup screw. Put high-pressure antiseize lubricant on the threads.



26. Use a socket wrench to tighten the seal backup screw in the valve body.



5 – Preventive maintenance

27. Put the flow reducer in the outlet adapter.



28. Put high-pressure antiseize lubricant on the outside threads and in the poppet seat cavity.

29. Put the poppet seat in the seat cavity of the outlet adapter.

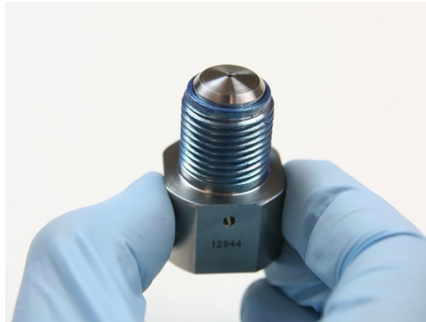

30. Put high-pressure antiseize lubricant on the surface of the poppet seat.

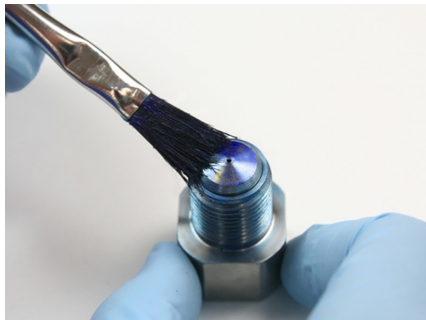

31. Turn the outlet adapter into the valve body until it is hand tight.

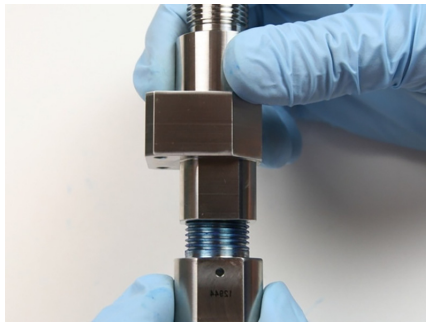

5 – Preventive maintenance

32. Turn the actuator housing into the valve body until it is hand tight.

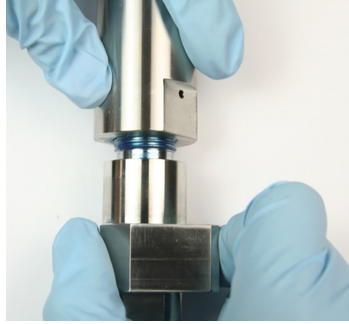

33. Use 2 wrenches to tighten the outlet adapter and the actuator housing into the valve body.
34. Use 2 wrenches to tighten the O-ring boss adapter in the actuator housing.
35. Install the bleed-down valve. Refer to **Install the bleed-down valve**, which begins on page 140.

5 – Preventive maintenance

Install the bleed-down valve



Failure to correct the cause of a leak can cause damage to the water fittings.

Service	Interval
Repair the bleed-down valve (page 130)	After every 1,000 hours of operation or if water leaks from the wastewater outlet or from the weep holes while the pump is running
Replace the bleed-down valve body	After every 3,000 hours of operation

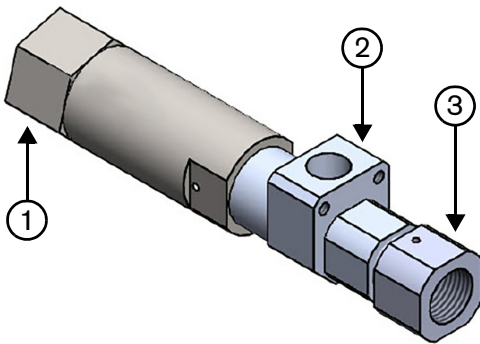

- 1 O-ring boss adapter
- 2 Valve body
- 3 Outlet adapter

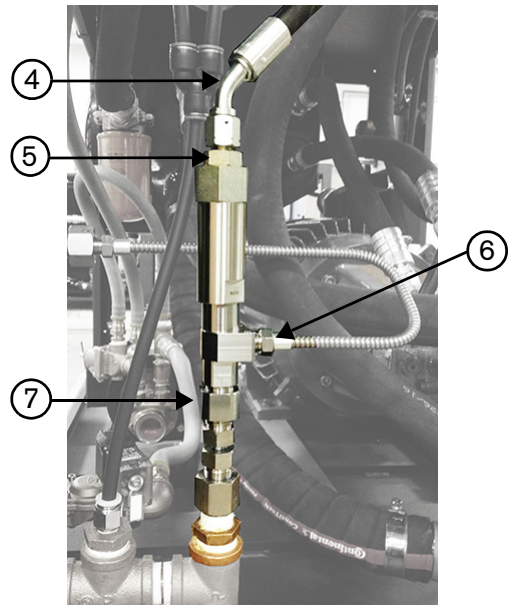

- 4 Hydraulic hose
- 5 Hydraulic hose fitting
- 6 High-pressure water fitting (gland nut)
- 7 3/8-inch gland nut



Required parts, tools, and materials

12880-912 Hydraulic fitting SAE O-ring (from 12981 Bleed-down valve II repair kit)

13969 Petroleum-based O-ring lubricant

Full set of standard open-ended wrenches

Adjustable wrench

Torque wrench

High-pressure antiseize lubricant such as Blue Goop or AccuGoop

5 – Preventive maintenance

1. Put high-pressure antiseize lubricant on the threads of the outlet adapter.
2. Use 2 wrenches to tighten the outlet adapter into the 3/8-inch gland nut.
3. Put high-pressure antiseize lubricant on the outside threads of the high-pressure water fitting.

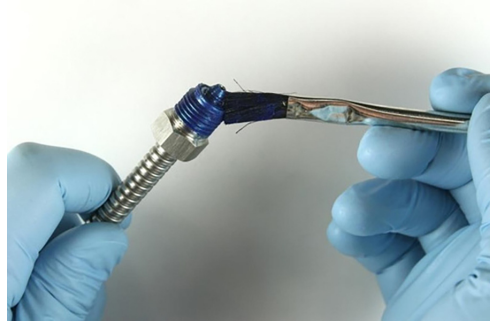

4. Use 2 wrenches to tighten the high-pressure water fitting in the valve body.



5. Replace the hydraulic fitting SAE O-ring on the hydraulic hose fitting.

 Put O-ring lubricant on the O-ring.

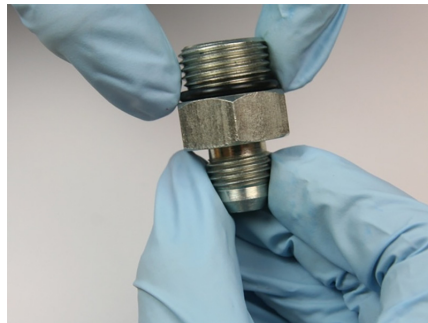

6. Use 2 wrenches to tighten the hydraulic hose fitting in the O-ring boss adapter.

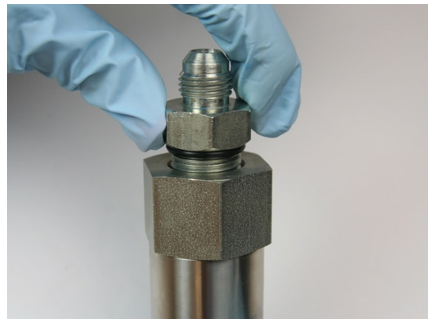

5 – Preventive maintenance

7. Use 2 wrenches to tighten the hydraulic hose to the hydraulic hose fitting.



8. Torque the fittings. Refer to the **Torque values** section, which begins on page 181.

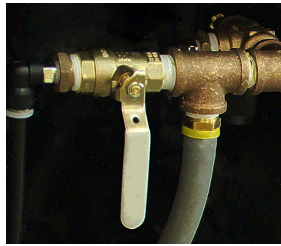

9. Close the water valve.



Water valve in the closed position

10. Turn ON the water to the pump.

Monitor for leaks. Identify the source of a leak and correct the problem. Refer to **Leaks** on page 163.

 WARNING	Do not attempt to repair a leak with pressure in the system.
 WARNING	Use a piece of cardboard or other solid material to check for leaks when the pump is on. Do not use hands, cloth, paper, or towels.

5 – Preventive maintenance

Bleed-down valve parts









12981 Bleed-down valve II repair kit

Part number	Description	Quantity
12880-912	Hydraulic fitting SAE O-ring	1
12880-908	SAE O-ring	1
11679-114	Piston O-ring, -114	1
11680-114	Piston O-ring backup, -114	1
12942	Needle	1
11324	Needle bushing	1
11323	Seal hoop	1
11321	High-pressure seal	1
11141	High-pressure poppet seat	1
11743	Flow reducer	1
16123	Wooden dowel	1
11447	High-vacuum grease, 5 oz.	1

Other parts

Part number	Description
11796	O-ring boss adapter
11778	Hydraulic piston
11779	Actuator housing
12945	Seal backup screw
12943	Bleed-down valve body
12944	Outlet adapter
13969	Petroleum-based O-ring lubricant

Start the pump after preventive maintenance

 WARNING	<p>Before removing lock-out or tag-out devices:</p> <ul style="list-style-type: none"> ▪ Follow the specific provisions of the employer's energy-control procedure. ▪ Inspect machines and parts to make sure that they are operationally intact and that nonessential items are removed from the area. ▪ Make sure that everyone is safely away from machines. <p>After removing the lock-out or tag-out devices but before reenergizing the machine, the make sure that all workers in the area of the equipment know that the devices are removed and that the machine is capable of being reenergized.</p>
 WARNING	<p>A turning motor shaft can be dangerous. Close all doors and replace all covers, including access covers.</p>
 WARNING	<p>Do not attempt to repair a leak with pressure in the system.</p>
 WARNING	<p>Use a piece of cardboard or other solid material to check for leaks when the pump is on. Do not use hands, cloth, paper, or towels.</p>
 CAUTION	<p>Failure to correct the cause of a leak can cause damage to the water fittings.</p>
	<p>Make sure that all fittings are tight after doing maintenance or repairing this equipment.</p>
	<p>Test the equipment before putting it into use.</p>
	<p>Remove all tools from the work area before starting the equipment.</p>

1. Turn ON the water to the pump.
2. Turn ON the electrical main.
3. Make sure that the primary breaker disconnect lever on the electrical enclosure door is set to ON.



The operator interface screen is illuminated when electricity to the pump is turned on.

4. Make sure that the LOCAL/REMOTE key switch on the operation panel is set to LOCAL.

These events occur when the key switch is set to LOCAL:

- The operator interface is used to run the pump.
- The REMOTE ACTIVE indicator light is off.
- The operator interface is the primary point of control.

5. Push the CONTROLS ON button to turn ON the control circuit inside the pump.



The pump can not be turned on until the control circuit is on.

5 – Preventive maintenance

6. Turn ON the pump in cooling mode.
7. Decrease the pump pressure. Refer to page 51 for instructions.
8. Touch the symbol on the operator interface to put the pump in running mode.
9. Touch the pierce-pressure mode symbol.
10. Turn ON the cutting head to remove air from the high-pressure lines. Watch for water to come out of the cutting head. This takes approximately 1 minute.



The intensifier strokes quickly while it pushes the air out of the lines.

11. Permit the intensifier to stroke for a few minutes to make sure that the seals are installed properly.
12. Turn OFF the cutting head.
Monitor for leaks. Identify the source of a leak and correct the problem. Refer to **Leaks** on page 163.
13. Increase the pump pressure to the desired pierce-pressure mode setpoint.
14. Touch the cut-pressure mode symbol. The intensifier strokes until the pump reaches the cut-pressure setting and then it stops stroking.
Monitor for leaks. Identify the source of a leak and correct the problem. Refer to **Leaks** on page 163.
15. Log maintenance activities. Open the maintenance screen to log and track all maintenance performed on the pump and the intensifier.

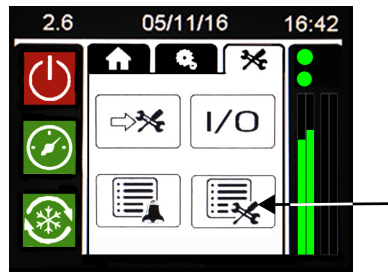

- a. Touch the applicable area on the image of the pump. Select the area where maintenance was performed.



5 – Preventive maintenance

b. Select each item and the reason for the maintenance.

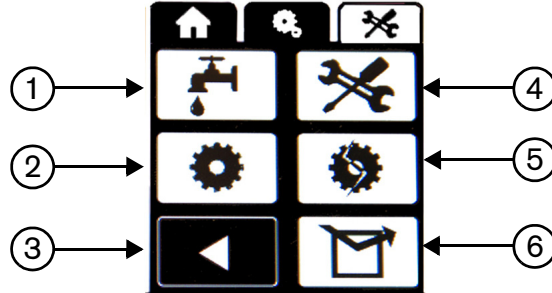

- | | | | |
|---|--|---|--------------------------------|
| 1 | Part is leaking | 4 | General preventive maintenance |
| 2 | Part is worn | 5 | Part is cracked |
| 3 | Return to the maintenance options screen | 6 | Other reason |

This information transfers to the maintenance log and is saved as a .CSV file on the SD card.

The pump is ready for operation.

Recycling and end of product life

At the end of the life of the product or its parts, recycle or dispose of materials and parts using an environmentally satisfactory method and in accordance with local regulations. If the product contains substances that are harmful to the environment, remove and dispose of them in accordance with current local regulations. This includes liquids such as hydraulic fluid.

Make sure that hazardous substances are disposed of safely and that the correct personal protective equipment is used. The safety specifications must be in accordance with the current local regulations at all times.

Preventive maintenance records

Problem found and work done

Date	
Hours	
Initials	
Date	
Hours	
Initials	
Date	
Hours	
Initials	
Date	
Hours	
Initials	
Date	
Hours	
Initials	
Date	
Hours	
Initials	
Date	
Hours	
Initials	

Preventive maintenance

5 – Preventive maintenance

Problem found and work done

Date	
Hours	
Initials	
Date	
Hours	
Initials	
Date	
Hours	
Initials	
Date	
Hours	
Initials	
Date	
Hours	
Initials	
Date	
Hours	
Initials	
Date	
Hours	
Initials	
Date	
Hours	
Initials	
Date	
Hours	
Initials	

Section 6

Parts lists

Genuine Hypertherm parts are the factory-recommended replacement parts for this pump. The Hypertherm warranty might not cover damage caused by using nongenuine Hypertherm parts.

To order parts, contact the original equipment manufacturer (OEM) or Hypertherm Inc. with the part numbers and quantities.

Hypertherm Waterjet
305 2nd Ave NW, Suite 115
New Brighton, MN 55112 USA
+1 866-566-7099
+1 651-294-8620 fax

Tools

12084 HyPrecision standard tool kit

Part number	Description
11448	AccuGoop, food-grade high-pressure antiseize lubricant, 4 oz.
11558	Seal installation locator tool
11811	Seal installation sleeve
11812	Seal installation push tool
12932	Seal installation spacer tool
11985	Seal housing removal tool
12019	Hex driver, 3/4 inch × 13-1/2 inch
12020	Deep square-drive socket, 3/4 inch × 3/4 inch
12021	Square-drive socket, 1-1/2 inch × 3/4 inch
12091	Torque wrench, 3/4-inch drive, 60 lbf·ft to 300 lbf·ft
13972	Filter wrench
13281	Granite lapping block, 22.86 cm × 30.48 cm × 5.08 cm (9 inch × 12 inch × 2 inch)
11210-12	Lapping paper, 12 micron
11210-15	Lapping paper, 15 micron

Preventive maintenance repair kits

Quantity refers to the number of units included with each part number.

15569 HyPrecision S-series standard spares kit

Part number	Description	Quantity
15563	HyPrecision premium high-pressure seal repair kit	2
15568	HyPrecision poppet repair kit	2
12981	Bleed-down valve II repair kit	1
11669	Indicator pin spring	2
11679-013	Indicator pin O-ring, -013	2
11680-013	Indicator pin O-ring backup, -013	2
15564	6-inch cotton-tipped applicator	2
11105	Water filter cartridge, 0.45 micron, 10 inch	1
11106	Water filter cartridge, 1.0 micron, 10 inch	1
11107	Water filter cartridge, 10 micron, 10 inch	1
16025	Hydraulic filter	1

15563 HyPrecision premium high-pressure seal repair kit

Part number	Description	Quantity
11018	High-pressure hoop, 1 inch	4
11024	High-pressure water seal, 1 inch	4
11447	High-vacuum grease, 5 oz.	1
11610	High-pressure seal backup (bronze)	2
11090	Hydraulic rod seal, 1 inch	2
11679-035	Check valve and seal housing O-ring, -035	4
11679-031	Check valve O-ring, -031	2
11680-035	Seal housing O-ring backup, -035	2

15568 HyPrecision S- and D-series poppet repair kit

Part number	Description	Quantity
11014	High-pressure poppet	2
11126	High-pressure poppet spring	2
11015	High-pressure poppet seat	2
11526	Low-pressure poppet	2
15564	6-inch cotton-tipped applicator	2

12981 Bleed-down valve II repair kit

Part number	Description	Quantity
11141	High-pressure poppet seat	1
12942	Needle	1
11321	High-pressure seal	1
11323	Seal hoop	1
11324	Needle bushing	1
12880-908	Hydraulic fitting SAE O-ring	1
12880-912	Hydraulic fitting SAE O-ring	1
11679-114	Piston O-ring, -114	1
11680-114	Piston O-ring backup, -114	1
11743	Flow reducer	1
16123	Wooden dowel	1
11447	High-vacuum grease, 5 oz.	1

Other parts

Lubricants

Part number	Description
11111	Blue Goop high-pressure antiseize lubricant
11448	AccuGoop, food-grade high-pressure antiseize lubricant, 4 oz.
11447	High-vacuum grease 5 oz.
13969	Petroleum-based O-ring lubricant
13186	Antiseize bolt lubricant (white lithium grease)

Fittings

Part number	Description
13157-60-4	High-pressure collar, 1/4 inch
13157-60-6	High-pressure collar, 3/8 inch
13158-60-4	High-pressure gland nut, 1/4 inch
13158-60-6	High-pressure gland nut, 3/8 inch

Electrical system

Part number	Description
11670	Proximity switch
11518	Indicator pin
11519	Indicator pin cap
11798	Split support ring

Hydraulic system

Part number	Description
16025	Hydraulic filter
12438	Suction strainer, 1-1/2 inch
11960	Suction strainer, 2-1/2 inch
14629	Filler-breather cap
12617	Switch, temperature and fluid level
11956	Pressure gauge, 5,000 psi, 1/4 NPT
11733	Shift valve and pilot assembly, 24 VDC
11805	Control manifold assembly
11954	Relief valve, high pressure
11955	Relief valve, low pressure
11964	Return diffuser, 2 inch

Low-pressure water system

Part number	Description
11829	Water filter housing
11835	Water accumulator
11841	Hose, 1/2 inch, 250 psi
12056	Boost pump motor, 1/2 hp
12061	Boost pump relief valve, 1/2-inch NPT
12614	Valve, brass, 1/2-inch NPT, 24 VDC
11767	Switch, filter water pressure
11836	Water-modulating valve
13897	TDS meter

High-pressure water system

Part number	Description
12280	Attenuator assembly, 1 liter
11595	Attenuator assembly, 2 liter
12943	High-performance bleed-down valve body
13384	Low-pressure seal kit
12579	Protective sheathing, 1/4 inch
12580	Protective sheathing, 3/8 inch
14688	Sheathing end cover, 1/4-inch high-pressure tubing
14687	Sheathing end cover, 3/8-inch high-pressure tubing

Intensifier high-pressure ends

11523	Check valve assembly
11520	Low-pressure poppet basket
11530	Output adapter
11522	High-pressure cylinder
11609	Seal housing
11521	Spacer tube
11608	Plunger bearing
11210-30	Lapping paper, 30 micron

6 – Parts lists

Intensifier hydraulic center section

11508	Piston
11673	Piston seal
11674	Wear ring
11593	Plunger retainer
11675	T-seal plunger coupler
11672	Nut, grade 8, 1 inch, -14
11310	Retaining ring
11502	Hydraulic cylinder
11554	Nut, threaded

Complete list of preventive maintenance kits, parts, tools, and materials

Kits	
12084 HyPrecision standard tool kit	15568 HyPrecision S- and D-series poppet repair kit
12981 Bleed-down valve II repair kit	15569 HyPrecision S-series standard spares kit
15563 HyPrecision premium high-pressure seal repair kit	

Parts	
11518 Indicator pin	11608 Plunger bearing
11520 Low-pressure poppet basket	11609 Seal housing
11521 Spacer tube	12943 High-performance bleed-down valve body
11522 High-pressure cylinder	11960 Suction strainer, 2-1/2 inch
11523 Check valve assembly	12438 Suction strainer, 1-1/2 inch
11530 Output adapter	14629 Filler-breather cap





Tools	
All wrenches and sockets are SAE	
13897 TDS meter	Flat-blade screwdriver
Full set of standard open-ended wrenches	Rubber mallet
Full set of standard crowfoot wrenches or sockets	Two 8-32 × 2-inch (or longer) socket-head cap screws
1/8-inch hex wrench	Infrared or other type of external-reading thermometer
5/32-inch hex wrench or hex-bit socket	Air pressure gauge (Schradler valve)
Adjustable wrench	Compressed air source
Torque wrench	Dental pick or similar tool (recommended)
Strap wrench or adjustable pliers	

Materials	
11210-30 30-micron lapping paper	Clean, lint-free towels
11111 Blue Goop high-pressure antiseize lubricant	Nonstick scouring pad
11448 AccuGoop food-grade high-pressure antiseize lubricant	Emery cloth (not coarser than 120 grit)
11447 High-vacuum grease	Masking tape
13186 Antiseize bolt lubricant (white lithium grease)	Container for a water sample
13969 Petroleum-based O-ring lubricant	Container for used hydraulic fluid
Isopropyl alcohol	Hose or pipe for draining hydraulic fluid
Clean, deionized water or filtered water	Clean funnel (recommended)
Antiwear (AW) mineral oil or synthetic hydraulic fluid, ISO viscosity grade (VG) 32 or 46	Bucket or pail (recommended)

Section 7

Troubleshooting

Safety

	Refer to the instruction manual. Read and understand all of the safety guidelines in this manual.
 DANGER	Dangerous voltage To reduce the risk of serious injuries or death, wear approved protection and follow safety recommendations when working with electricity.
 WARNING	Use a piece of cardboard or other solid material to find leaks when the pump is operating. Do not use hands, cloth, paper, or towels.
 WARNING	Do not touch a hot surface. Fittings can get hot, especially when they are not tightened properly.
 CAUTION	Failure to correct the cause of a leak can cause damage to the water fittings.

Hypertherm products are designed and manufactured with a commitment to continuous quality control and safety. Contact a Hypertherm Technical Service Associate for information and support regarding the installation, operation, maintenance, and repair of this equipment.

Tips

- Close all doors and replace all covers, including access covers.
- Keep all interior parts and surfaces clean. Put all parts on a clean work surface.
- Handle high-pressure parts with clean hands.
- Before reassembling high-pressure or hydraulic parts, clean the parts to remove dirt and other contaminants.

Alarm screens

The controller monitors activities while the pump is running. When the controller detects a problem with the system, the operator interface shows the fault condition and the stack light blinks. When operating the intensifier or primary motor is likely to damage the equipment, the intensifier and the primary motor turn off.

To stop an alarm, touch the screen showing the fault condition. Touch ACK on the screen, then touch ESC. The stack light stops blinking.

The amber stack light blinks to signal a condition that requires attention. The red stack light blinks to show that a fault has occurred.

If a fault message is still showing after the alarm condition is corrected, touch FAULT RESET on the screen. This clears the fault and permits the pump to be restarted.

 Not all pump functions are monitored by the controller.

 The alarm log shows recent alarms and when they occurred. This can be helpful for troubleshooting.

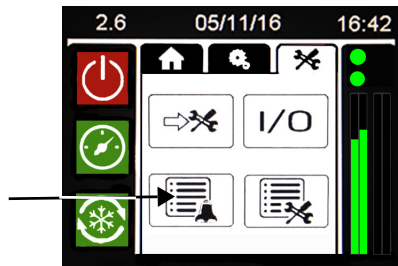

The pump will not start

If the pump does not start or does not increase pressure, check these possible causes.

- The primary power is off.
- The primary breaker disconnect lever is off.
- The LOCAL/REMOTE key switch is set to LOCAL and the pump is being operated remotely.
- The pump is in pierce-pressure mode and the pierce-pressure control knob is turned anticlockwise too much.
- The cut-pressure control knob is turned anticlockwise too much.
- The pressure-enable valve has failed.
- A motor overload relay has tripped.
- A fuse in the electrical enclosure has blown.
- The pressure-relief valve on the primary hydraulic manifold has failed.

Intensifier

Stroking problems

The intensifier usually strokes faster during startup and when changing from pierce-pressure mode to cut-pressure mode.

The motor's wattage and the size of the hydraulic pump determine the maximum intensifier stroke rate.

The intensifier does not stroke to either side

Take these actions:

- Make sure that the intensifier is enabled.
- Make sure that the cutting head is turned on.
- Look at the proximity switch lights. If both amber lights are on at the same time, a proximity switch might have failed, an indicator spring might be broken, or an indicator pin might be stuck. Inspect all parts to find the cause of the fault.
- Examine the cord ends on the proximity switches for damage.
- Make sure that the indicator pins and springs are not damaged.

The intensifier strokes to 1 side and then stalls on the same side

Take these actions:

- Exchange the proximity switches with each other (but not the wires).
- Replace the proximity switches.
- Examine the indicator pin for burrs. The pins should move freely to the bottom of the bore.
- Make sure that the indicator pin springs are not broken and that they are the same length.
- While the pump is in cooling mode, touch the box on the operator interface that matches the side the of the intensifier stall. If the intensifier strokes to the opposite side, the problem is electrical. If the intensifier does not move, the problem is mechanical.

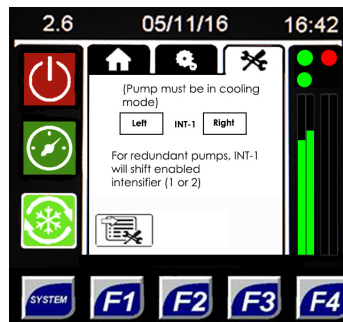

7 – Troubleshooting

The intensifier strokes but there is not enough pressure at the cutting head

Take these actions:

- Replace the water filters. Refer to page 91 for instructions.
- Repair or replace the thimble filter for the on/off valve.
- Make sure that there is not an obstruction in the high-pressure tubing.
- If an output adapter is hot, check the high-pressure poppet and the high-pressure poppet seat.
- If the bleed-down valve is hot or if water is coming out of the pump drain line, repair or replace the bleed-down valve.
- Make sure that the number of orifices and their sizes are sufficient for the pump's output. Refer to the **Troubleshooting** section, which begins on page 157.
- The hydraulic piston seals are worn. Contact a Hypertherm Technical Service Associate for assistance.
- If a high-pressure cylinder is hot, disassemble it and look for flaws, deterioration, erosion marks, or cracks in the parts, including the check valve and piston seal.

The intensifier is overstroking

Fault/warning	Stack light	Result
Intensifier overstroke to the right	Red	The intensifier turns off. The pump runs in cooling mode.
Intensifier overstroke to the left		
Intensifier overstroke in both directions		

The intensifier usually strokes smoothly to the left and to the right at the same speed. An overstroke fault occurs when the hydraulic piston travels faster in 1 or both directions than the waterjet pump can support.





The intensifier usually strokes faster during startup and when changing from pierce-pressure mode to cut-pressure mode.

The overstroke alarm is caused by 3 conditions: overstroking to the right, overstroking to the left, or overstroking in both directions. If the overstroke alarm is on, take these actions.

1. Turn OFF the cutting head.
2. Touch the symbol on the operator interface to put the pump in running mode.
3. Turn ON the cutting head. The intensifier starts stroking.
4. Put the pump in cut-pressure mode.
5. Monitor the intensifier stroke rate indicator on the operator interface.

7 – Troubleshooting

If the intensifier overstrokes in both directions

Possible cause	Solution
<p>The orifice is worn, has failed, or is improperly installed.</p> <p>A worn or damaged orifice increases the demand for high-pressure water from the intensifier.</p>	<p>Reinstall or replace the orifice.</p>
<p>The high-pressure water seals are worn or damaged.</p>	<p>Replace the high-pressure water seals.</p>
<p>The high-pressure plumbing (a water line or a fitting) is leaking.</p>	<p>Identify the source of a leak and correct the problem.</p>
<p>The bleed-down valve is leaking.</p>	<p>Repair or replace the bleed-down valve.</p>
<p>The needle and the seat in the cutting head are leaking.</p>	<ul style="list-style-type: none"> ▪ Repair or replace the cutting head. ▪ Repair or replace the on/off valve. ▪ Replace the needle and the seat.
<p>The low-pressure water relief valve is venting water to the drain.</p>	<p>Remove the 3/8-inch tubing from the valve at the outlet fitting and monitor for leaks.</p> <p> Contact a Hypertherm Technical Service Associate for assistance.</p>
<p>The postfilter water-pressure gauge shows that the low-pressure water is at less than 2.76 bar or 275.79 kPa (40 psi).</p>	<p>If the difference between the values on the pre- and postfilter water-pressure gauges is higher than 0.69 bar or 68.95 kPa (10 psi), replace both water filters.</p>
<p>The prefilter water-pressure gauge shows that the low-pressure water is at less than 2.76 bar or 275.79 kPa (40 psi).</p> <p> The intensifier can starve for water without activating the low-pressure alarm for the low-pressure water.</p>	<ul style="list-style-type: none"> ▪ Make sure that the water to the pump is turned on. ▪ Make sure that the water valve is closed. ▪ Make sure that the low-pressure water is connected to the intensifier. ▪ Loosen a brass fitting after the low-pressure water solenoid while the pump is running. Water should stream immediately from the loosened fitting.

 Instructions about how to disassemble the intensifier and how to repair or replace parts start on page 97.

7 – Troubleshooting

If the intensifier overstrokes in 1 direction

Possible cause	Solution
<p>A low-pressure poppet is sticking, worn, or damaged.</p> <p>Overstroking to the left means that there is a failure of the low-pressure poppet on the left side of the intensifier.</p> <p>Overstroking to the right means that there is a failure of the low-pressure poppet on the right side of the intensifier.</p>	<ul style="list-style-type: none">▪ Examine the face of the poppet and the mating face on the check valve. Make sure that the faces are smooth and flat and have a nearly mirrored finish.▪ Repair or replace the poppet.▪ Make sure that the low-pressure poppet fits in the basket without sticking.▪ Repair or replace the check valve.
<p>A high-pressure poppet is sticking, worn, or damaged.</p> <p>Overstroking to the left means that there is a failure of the high-pressure poppet on the right side of the intensifier.</p> <p>Overstroking to the right means that there is a failure of the high-pressure poppet on the left side of the intensifier.</p>	<ul style="list-style-type: none">▪ Monitor the temperature of the output adapter on the intensifier end opposite the direction of overstroke. If the output adapter is hot, remove it from the check valve and examine the high-pressure poppet, the spring, and the seat.▪ Replace the high-pressure poppet, the spring, and the seat.



Instructions about how to disassemble the intensifier and how to repair or replace parts start on page 97.

Leaks



Failure to correct the cause of a leak can cause damage to the fittings.

Make sure that the tubing, the water fittings, and the quick disconnects inside and outside of the pump are not leaking.

Damage to the high-pressure water seals and the hoops is the most common cause of water leaking from the intensifier. Water dripping from the high-pressure cylinder shows that the seals will soon require changing. One drop every few strokes means that the seals should be watched. More than 1 drop with each stroke means that the seals in that high-pressure cylinder should be changed at the first opportunity.

Weep holes throughout the high-pressure water system let water escape from leaking parts. A leak can mean that there is a faulty part, a loose fitting, or a damaged seat.

Water can enter the hydraulic system if the weep holes in the dynamic seal backup or the seal housing are blocked. Make sure that the weep holes are free of debris.

 Look for leaks at both ends of the high-pressure cylinder.

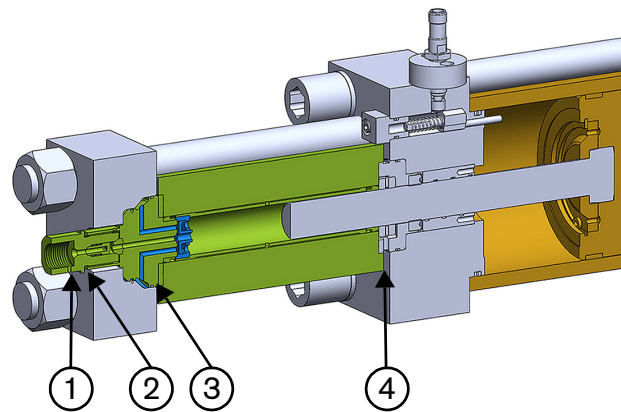

1 Output adapter weep hole

2 High-pressure seat weep hole

3 Static seal leak point

4 Dynamic seal housing weep hole

7 – Troubleshooting

Water leak from	Possible cause
Output adapter weep hole	<ul style="list-style-type: none"> ▪ A fitting on the high-pressure water tubing is not tight enough. ▪ The tubing end is cracked or damaged. ▪ The output adapter has failed.
High-pressure seat weep hole	<ul style="list-style-type: none"> ▪ The output adapter is loose. ▪ The high-pressure poppet seat has failed. ▪ The seat face of the check valve is cracked. ▪ The check valve O-ring nearest to the output adapter has failed.
Static seal leak point	<ul style="list-style-type: none"> ▪ A high-pressure seal has failed. ▪ The check valve O-ring nearest to the high-pressure seal has failed.
Dynamic seal housing weep hole	A high-pressure seal has failed.

Hydraulic fluid leak from	Possible cause
Dynamic seal housing weep hole	<ul style="list-style-type: none"> ▪ The rod seal has failed. ▪ The O-ring or O-ring backup on the seal housing has failed.
Anywhere on the intensifier	An O-ring has failed.

A leaking high-pressure seal in the intensifier can force water past the rod seal and into the hydraulic fluid. Hydraulic fluid contaminated with water has a milky appearance. Contaminated hydraulic fluid can damage the hydraulic pump.

In water-cooled systems, water can enter the hydraulic system through the heat exchanger. If this is suspected to be the case, contact a Hypertherm Technical Service Associate for assistance.

Replace the hydraulic fluid and examine all of the parts, including the inside of the hydraulic fluid tank, the hydraulic hoses, and the seals. Refer to page 84 for instructions.



Sometimes it is necessary to drain and flush out other areas such as the shift valve, the hydraulic manifolds, and the hydraulic pump.

Short seal life

If the high-pressure water seals have a short life, take these actions.

- Make sure that the mating surfaces are smooth and free of debris.
- Repair or replace the high-pressure cylinder and plunger.
- Make sure that the water quality is within satisfactory ranges. Refer to the **Water quality** section, which begins on page 188.
- Examine the ends of the high-pressure cylinder for cracks.
- Replace the high-pressure water seals and hoops.
- Check the air pressure in the water accumulator tank. Refer to page 89 for instructions.
- Replace the high-pressure cylinder.

If the high-pressure seal backups have a short life, make sure that the plunger bearing is not worn.

Hydraulic fluid

Low pressure

The most common causes of low hydraulic fluid pressure are a leak from a fitting or a hose in the hydraulic system and the loss of hydraulic fluid during routine maintenance.

A float switch in the hydraulic fluid tank causes an alarm when the hydraulic fluid level is too low.

Fault/warning	Stack light	Result
Low hydraulic fluid	Red	The intensifier turns off. The pump turns off.

If the hydraulic fluid pressure is low:

- Examine the pump for hydraulic fluid leaks. Pay attention to these areas:
 - Hydraulic fluid tank access cover
 - Hydraulic connections
 - Valves
 - Top and bottom decks
- Make sure that the hydraulic fluid level is at the top mark on the sight gauge. Add hydraulic fluid, if necessary. Refer to page 78 for instructions.

High temperature

A sensor in the hydraulic fluid tank monitors the hydraulic fluid temperature with 3 switches. One switch closes at 45.0°C (113°F), 1 switch opens at 55.0°C (131°F), and 1 switch opens at 65.0°C (149°F).

Fault/warning	Stack light	Result
The hydraulic fluid temperature is equal to or higher than 55.0°C (131°F)	Amber	The intensifier continues running. The pump continues running.
The hydraulic fluid temperature is equal to or higher than 65.0°C (149°F)	Red	The intensifier turns off. The pump runs in cooling mode for 3 minutes. If the temperature stays at or higher than 65.0°C (149°F), the pump turns off.

The optimum operating temperature for hydraulic fluid in this system is 40.6°C (105°F) to 46.1°C (115°F). If the temperature is outside of this range, adjust the hydraulic fluid temperature. Refer to page 82 for instructions.

High altitude and high ambient temperatures can affect the temperature of hydraulic fluid. Fluid that is too cool is thick and causes increased friction and poor lubrication. Fluid that is too hot is thin, which accelerates wear on the parts, increases the formation of sludge, degrades the fluid, and decreases lubrication and protective qualities.

7 – Troubleshooting

An increase in pump temperature can show that there is a problem with the cooling system.

Water-cooled systems

<p>The cooling water temperature is too high.</p>	<ul style="list-style-type: none"> ▪ Make sure that the cooling water is turned on. ▪ Adjust the hydraulic fluid temperature. Refer to page 81 for instructions.
--	--

Air-cooled systems

 <p>CAUTION</p>	<p>Do not adjust the setting on the thermal overload or the fan motor starter unless instructed to do so by a Hypertherm Technical Service Associate.</p>
---	---

<p>The ambient temperature is too high.</p>	<p>Consider supplemental cooling.</p>
<p>The fan is not generating enough airflow.</p>	<ul style="list-style-type: none"> ▪ Make sure that the fan motor breaker is not tripped. ▪ The air cooler fins are dirty or clogged. ▪ The thermal overload device on the fan motor starter inside the electrical enclosure turned off the fan motor. ▪ Turn the OL-FAN dial to RESET and then to AUTO.

All systems

<p>The cord for the hydraulic fluid temperature/level sensor is unplugged or damaged.</p>	<ul style="list-style-type: none"> ▪ Plug in the sensor. ▪ Replace the cord.
<p>The temperature sensor is faulty or damaged.</p>	<p>Replace the sensor.</p>

Water pressure

No water pressure or low water pressure



The pump pressure usually falls when the cutting head is turned on.

If the water coming from the intensifier is at a lower pressure than expected:

- Make sure that the cut pressure is set correctly. Refer to page 60 for instructions.
- Make sure that the pump is not in pierce-pressure mode.

If the value on the prefilter water-pressure gauge is less than 2.76 bar or 275.79 kPa (40 psi), the water pressure going to the intensifier is too low.

Fault/warning	Stack light	Result
The low-pressure water is at less than 2.76 bar or 275.79 kPa (40 psi)	Red	The intensifier turns off. The pump runs in cooling mode.

The most common cause of this alarm is a lack of water to the pump. A pressure switch after the boost pump senses the water pressure. If the water pressure falls to a value that is less than the setpoint, the monitoring circuit opens and causes a fault.

A pressure switch after the water filters senses the water pressure to the intensifier. A sustained pressure of less than 2.76 bar or 275.79 kPa (40 psi) causes the pump to turn off. This protects the equipment from running without enough pressure to the intensifier.

Check the water flow. While the pump is running, loosen a brass fitting after the low-pressure water solenoid. If a very small amount of water or no water leaks immediately from the loosened fitting, consider these causes.

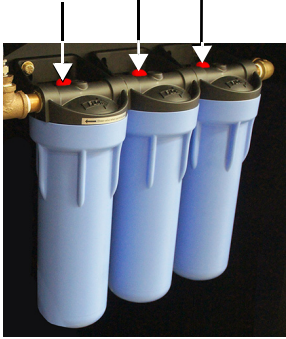
Possible cause	Solution
Water isn't flowing through the water filters.	<ol style="list-style-type: none"> 1. Turn ON the pump in cooling mode. 2. Push the water filter purge buttons until water comes out from under each button. 
The relief valve on the pump manifold has failed.	Replace the valve.

7 – Troubleshooting

Possible cause	Solution
The water is turned off.	Make sure that the water to the pump is turned on.
The water valve is open.	Make sure that the water valve is closed.
The boost pump bypass relief valve is not adjusted properly.	Refer to Adjust the boost pump pressure on page 201.
The boost pump has failed.	<ol style="list-style-type: none"> 1. Open the water valve to drain the water from the system. Make sure that the value on both water-pressure gauges is 0.0 bar or 0 kPa (0 psi). 2. Examine the 10-micron water filter. If the filter is black, the boost pump has failed and must be replaced. Refer to page 91 for instructions.
The boost pump thermal overload (MS-BOOST/OL-BOOST) has tripped.	<ol style="list-style-type: none"> 1. Turn the knob clockwise to the on position. When released, the knob snaps anticlockwise to 0. 2. Turn the knob clockwise to the on position.
Pressure is lost because of a leak.	<ul style="list-style-type: none"> ▪ Identify the source of a leak and correct the problem. Refer to Leaks on page 163. ▪ If the intensifier strokes when it is in cut-pressure mode with the cutting head turned off, check the bleed-down valve and the high-pressure tubing for leaks.
A low-pressure poppet is sticking, worn, or damaged.	<ul style="list-style-type: none"> ▪ Examine the face of the poppet and the mating face on the check valve. Make sure that the faces are smooth and flat and have a nearly mirrored finish. ▪ Repair or replace the poppet. ▪ Make sure that the low-pressure poppet fits in the basket without sticking. ▪ Repair or replace the check valve
A high-pressure poppet is sticking, worn, or damaged.	Replace the high-pressure poppet, the spring, and the seat.
The boost pump is not operating.	<ul style="list-style-type: none"> ▪ Look through the bell housing to make sure that the coupler is turning. ▪ In rare cases, the boost pump motor requires replacement. Contact a Hypertherm Technical Service Associate for assistance.

Water pressure is too high

If the value on the prefilter water-pressure gauge is higher than 7.93 bar or 792.90 kPa (115 psi), the water pressure is too high. If the value on either water-pressure gauge is more than 8.62 bar or 861.84 kPa (125 psi), contact a Hypertherm Technical Service Associate for assistance.

The pump's low-pressure water parts are rated for a maximum pressure of 8.62 bar or 861.84 kPa (125 psi). In environments with high supply water pressure, the boost pump can increase the water pressure to more than the maximum. This can damage the filters and other parts.



A secondary bypass relief valve before the filter assembly reduces the risk of damage. This relief valve is set to 8.27 bar/827.37 kPa (120 psi) at the factory and should not be adjusted.

Possible cause	Solution
The boost pump is not needed.	<p>If the value on the prefilter water-pressure gauge is higher than 4.83 bar or 482.63 kPa (70 psi), turn OFF the boost pump.</p> <ol style="list-style-type: none"> 1. In the electrical cabinet, turn the switch on the boost pump motor contactor to 0. 2. Turn OFF boost fault monitoring. <ol style="list-style-type: none"> a. On the operator interface, go to the Settings screen. Refer to the Settings screen section, which begins on page 54. b. Touch the pump settings symbol. c. Touch System Settings. d. Touch the Boost Fault Monitor status indicator. Green shows enabled status. Red shows disabled status.
The boost pump bypass relief valve is not adjusted properly.	Refer to Adjust the boost pump pressure on page 201.
A water filter is clogged.	Replace the water filters.

Motor fault

Fault/warning	Stack light	Result
Primary motor fault	Red	The intensifier turns off. The pump turns off.

A primary motor fault means that there is a problem starting or running the motor. If this is suspected to be the cause of the alarm, take these actions.

- Make sure that an orifice is not broken.
- Make sure that the plumbing is not leaking.
- Examine the primary motor for an electrical short and for loose or damaged wiring.
- Examine the electrical enclosure for loose or damaged wiring.

Noisy operation

If air enters the hydraulic system, the pump becomes noisy during operation. Use a 13-mm socket or wrench to tighten both hose clamps on the suction hose that goes from the hydraulic fluid tank to the bottom of the primary hydraulic pump.

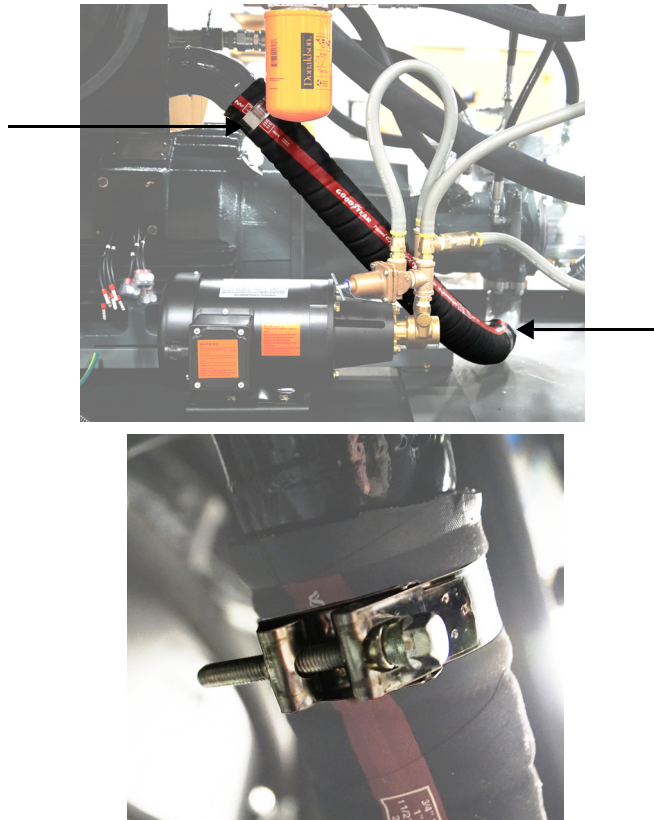

- 📄 The manufacturer recommends tightening the hose clamps to a maximum of 30 N·m (22 lbf·ft).
- 📄 If the pump is still noisy after tightening the hose clamps, contact a Hypertherm Technical Service Associate.

Section 8

Pump specifications

This section includes details about the pump, including this information:

- Power and water specifications and orifice sizes for each pump model
- Physical qualities such as dimensions, weight, and capacity
- Recommended operating conditions
- Information about fasteners and fittings

All models

Hydraulic fluid

Type	Antiwear (AW) mineral oil or synthetic hydraulic fluid, ISO viscosity grade (VG) 32 or 46
Tank capacity	151 L (40 gallons)
Maximum temperature	54.4°C (130°F)
Maximum pressure Hydraulic pump pressure limit set at the factory	217.18 bar or 21,718 kPa (3,150 psi)

Operating conditions

	Minimum	Maximum
Relative humidity	—	95%
Storage temperature Water not drained	1.7°C (35°F)	—
Ambient operating temperature	4.4°C (40°F)	35.0°C (95°F)

 If the cooling water or the low-pressure water temperature is higher than 23.9°C (75°F), cool the water before use. Water that is too warm is inefficient for cooling and can reduce high-pressure seal life.

Cooling requirements

	Do not use glycol solution in a chiller at a concentration of more than 25%.
---	--

HyPrecision pump model	kW (minimum)	Refrigeration tons (minimum tons)	Heat removal requirement (minimum Btu/hour)
15	3	0.85	10,000
30	6	1.70	20,000
50 and 50S	9	2.70	32,000
60S	11.5	3.30	40,000
75S	14	4.00	48,000
100D	19	5.30	64,000
150D	28	8.00	96,000

 Refrigeration tons is the heat transfer required at 0°C (32°F) to make 1 short ton (2,000 lb) of ice in 24 hours.
3.5 kW = 1 refrigeration ton = 12,000 Btu/hour

 Using a chiller with a water-glycol solution reduces the efficiency of the heat exchanger.

HyPrecision 50S

Dimensions and weights

Width	1,016 mm (40 in.)	Shipping weight	1,324 kg (2,920 lb)
Length	1,930 mm (76 in.)	Operating weight	1,406 kg (3,100 lb)
Height	1,422 mm (56 in.)		

 The shipping weight is for the pump, the pallet, and the packaging. Exact weights are taken at shipment. Operating weight is for an unpackaged pump with hydraulic fluid.

37 kW, 50 hp	50 Hz	60 Hz	
Voltage	400 V	208 V to 230 V	460 V
Full-load current	72.4 A	138.0 A to 126.0 A	62.0 A
Primary circuit breaker rating	80.0 A	150.0 A	80.0 A

		50 Hz	60 Hz
CUTTING WATER IN	Minimum	Maximum	
Flow	7.6 L/minute (2 gallons/minute)	—	
Pressure	2.76 bar or 275.79 kPa (40 psi)	7.93 bar or 792.90 kPa (115 psi)	
CUTTING WATER OUT			
Flow	—	3.8 L/minute (1 gallon/minute)	4.1 L/minute (1.07 gallons/minute)
Pressure	551.58 bar or 55,158 kPa (8,000 psi)	4,136.85 bar or 413,685 kPa (60,000 psi)	
Continuous pressure	—	4,136.85 bar or 413,685 kPa (60,000 psi)	
Cutting water pressure factory setpoint	—	4,137 bar or 413,685 kPa (60,000 psi)	
Piercing water pressure factory setpoint	1379 bar or 137,895 kPa (20,000 psi)	—	
COOLING IN and COOLING OUT			
Flow	11.4 L/minute (3 gallons/minute)	—	
Pressure	2.76 bar or 275.79 kPa (40 psi)	7.93 bar or 792.90 kPa (115 psi)	

8 – Pump specifications

This model supports these orifice sizes.

Number of orifices			
1	0.35 mm (.014 in.)	4	0.18 mm (.007 in.)
2	0.25 mm (.010 in.)	5	0.15 mm (.006 in.)
3	0.20 mm (.008 in.)	6	0.13 mm (.005 in.)

HyPrecision 60S

Dimensions and weights

Width	1,016 mm (40 in.)	Shipping weight	1,370 kg (3,020 lb)
Length	1,930 mm (76 in.)	Operating weight	1,451 kg (3,200 lb)
Height	1,422 mm (56 in.)		

 The shipping weight is for the pump, the pallet, and the packaging. Exact weights are taken at shipment. Operating weight is for an unpackaged pump with hydraulic fluid.

44.7 kW, 60 hp	50 Hz	60 Hz
Voltage	400 V	460 V
Full-load current	89.0 A	71.1 A
Primary circuit breaker rating	100.0 A	100.0 A

CUTTING WATER IN	Minimum	Maximum
Flow	9.5 L/minute (2.5 gallons/minute)	—
Pressure	2.76 bar or 275.79 kPa (40 psi)	7.93 bar or 792.90 kPa (115 psi)
CUTTING WATER OUT		
Flow	—	4.9 L/minute (1.3 gallons/minute)
Pressure	551.58 bar or 55,158 kPa (8,000 psi)	4,136.85 bar or 413,685 kPa (60,000 psi)
Continuous pressure	—	4,136.85 bar or 413,685 kPa (60,000 psi)
Cutting water pressure factory setpoint	—	4,136.85 bar or 413,685 kPa (60,000 psi)
Piercing water pressure factory setpoint	1,38.95 bar or 137,895 kPa (20,000 psi)	—
COOLING IN and COOLING OUT		
Flow	11.4 L/minute (3 gallons/minute)	—
Pressure	2.76 bar or 275.79 kPa (40 psi)	7.93 bar or 792.90 kPa (115 psi)

8 – Pump specifications

This model supports these orifice sizes.

Number of orifices			
1	0.41 mm (.016 in.)	4	0.20 mm (.008 in.)
2	0.28 mm (.011 in.)	5	0.18 mm (.007 in.)
3	0.23 mm (.009 in.)	6	0.15 mm (.006 in.)

HyPrecision 75S

Dimensions and weights

Width	1,016 mm (40 in.)	Shipping weight	1,415 kg (3,120 lb)
Length	1,930 mm (76 in.)	Operating weight	1,497 kg (3,300 lb)
Height	1,422 mm (56 in.)		

 The shipping weight is for the pump, the pallet, and the packaging. Exact weights are taken at shipment. Operating weight is for an unpackaged pump with hydraulic fluid.

56 kW, 75 hp	50 Hz	60 Hz
Voltage	400 V	460 V
Full load current	103.0 A	87.1 A
Primary circuit breaker rating	125.0 A	100.0 A

		50 Hz	60 Hz
CUTTING WATER IN	Minimum	Maximum	
Flow	11.4 L/minute (3 gallons/minute)	—	
Pressure	2.76 bar or 275.79 kPa (40 psi)	7.93 bar or 792.90 kPa (115 psi)	
CUTTING WATER OUT			
Flow	—	5.7 L/minute (1.49 gallons/minute)	6.1 L/minute (1.60 gallons/minute)
Pressure	551.58 bar or 55,158 kPa (8,000 psi)	4,136.85 bar or 413,685 kPa (60,000 psi)	
Continuous pressure	—	4,136.85 bar or 413,685 kPa (60,000 psi)	
Cutting water pressure factory setpoint	—	4,136.85 bar or 413,685 kPa (60,000 psi)	
Piercing water pressure factory setpoint	1,38.95 bar or 137,895 kPa (20,000 psi)	—	
COOLING IN and COOLING OUT			
Flow	11.4 L/minute (3 gallons/minute)	—	
Pressure	2.76 bar or 275.79 kPa (40 psi)	7.93 bar or 792.90 kPa (115 psi)	

8 – Pump specifications

This model supports these orifice sizes.

Number of orifices			
1	0.43 mm (.017 in.)	4	0.23 mm (.009 in.)
2	0.30 mm (.012 in.)	5	0.20 mm (.008 in.)
3	0.25 mm (.010 in.)	6	0.18 mm (.007 in.)

Torque values

Fasteners

When installing more than 1 fastener on a part, tighten each fastener in 68 N·m (50 lbf·ft) increments using a repeating cross pattern until the recommended torque is reached.

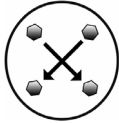

Because of high forces inside the intensifier, all bolts and cap screws that fasten load-carrying parts are grade 8. Fasteners that are exposed to cyclic loading also use lock washers. Torque load-carrying fasteners to the specifications in these tables unless otherwise noted. Torque values can vary depending on thread condition. A sufficient seal can be made at values much lower than the maximum values shown in the table. Use only enough torque to make a sufficient seal.

This chart applies to all fasteners used on hydraulic and high-pressure water parts.

Special fasteners

These torque values are for bolts that are coated in antiseize bolt lubricant (white lithium grease).

	Wrench size	N-m	lbf·ft
High-pressure end cap nut	1-1/2 inch	373	275
Intensifier cap screw	7/8 inch	373	275
Hydraulic fluid tank access cover	15/16 inch	27	20
Proximity switch cap screw	3/16-inch hex	11	8
Indicator pin cap screw	5/32-inch hex	5	4

SAE J518 flange bolts

These torque values are for bolts that are coated in antiseize bolt lubricant (white lithium grease). Lubricate the O-rings with hydraulic fluid or O-ring lubricant before assembly. To make a good seal, the sealing face must be parallel to the mating surface and the bolt tension must be even. Align the flange face to the mating surface.

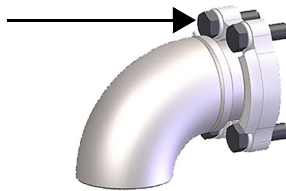

1/16-inch dash size	Bolt size	Code 61 grade 8		Code 62 grade 8	
		N-m	lbf·ft	N-m	lbf·ft
-08	5/16-28 inch	33	24	33	24
-12	3/8-16 inch	60	44	60	44
-16	3/8-16 inch	60	44	92	68
-20	7/16-14 inch	92	68	150	111
-24	1/2-13 inch	150	111	296	218

8 – Pump specifications

Fittings

	Do not use lubricants on low-pressure water fittings.
---	---

These charts apply to all hydraulic and high-pressure water fittings. Use a high-pressure antiseize lubricant such as Blue Goop or AccuGoop on high-pressure water fittings.

Special fittings

	Wrench size	Torque	
		N·m	lbf·ft
Output adapter	1 inch	41 to 47	30 to 35
High-pressure water fittings (gland nuts)			
1/4 inch	5/8 inch	20 to 34	15 to 25
3/8 inch	13/16 inch	47 to 61	35 to 45
9/16 inch	1-3/16 inch	81 to 102	60 to 75

Use these values when no other torque value is identified. Other torque specifications are included on the technical drawings.

8 – Pump specifications

Hydraulic fittings



Lubricate the O-rings with hydraulic fluid or O-ring lubricant before assembly.

NPT

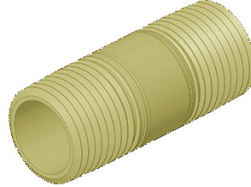

Size	Standard maximum torque		Maximum torque value when using thread sealant (75% of standard maximum)		Maximum torque value when using a male tapered pipe thread with a female straight or parallel pipe thread (50% of standard maximum)	
	N-m	lbf-ft	N-m	lbf-ft	N-m	lbf-ft
1/4 inch	34	25	26	19	18	13
3/8 inch	47	35	35	26	24	18
1/2 inch	61	45	46	34	31	23
3/4 inch	75	55	56	41	38	28
1 inch	88	65	66	49	45	33
1-1/4 inch	108	80	81	60	54	40
1-1/2 inch	129	95	96	71	65	48

This table shows maximum values. The torque necessary to make a sufficient seal depends on the condition of the pipe threads and can be much lower than the maximum.



Hypertherm recommends using thread sealant on all NPT hydraulic fittings.

8 – Pump specifications



Sizes -08 and smaller are not tolerant of overtorquing. Overtorquing reduces the clamping force, which causes an insufficient seal.

Steel JIC 37°



Brass JIC 37°



SAE O-ring boss









1/16-inch dash size	Minimum		Maximum		Minimum		Maximum		Minimum		Maximum	
	N-m	lbf-ft	N-m	lbf-ft	N-m	lbf-ft	N-m	lbf-ft	N-m	lbf-ft	N-m	lbf-ft
-04	14	10	15	11	7	5	8	6	14	10	16	12
-06	23	17	26	19	16	12	20	15	24	18	27	20
-08	46	34	52	38	27	20	33	24	43	32	47	35
-10	68	50	76	56	46	34	54	40	62	46	68	50
-12	95	70	106	78	72	53	81	60	88	65	95	70
-16	127	94	141	104	100	74	111	82	125	92	136	100
-20	168	124	187	138	102	75	113	83	169	125	190	140
-24	212	156	235	173	107	79	118	87	203	150	224	165
	Lubricate the threads of JIC steel fittings with hydraulic fluid.				Do not lubricate brass JIC fittings.				Do not use thread sealant on SAE hydraulic fittings.			

Section 9



Installation

Safety

	Refer to the instruction manual. Read and understand all of the safety guidelines in this manual.
 DANGER	Dangerous voltage To reduce the risk of serious injuries or death, wear approved protection and follow safety recommendations when working with electricity.
 WARNING	A waterjet is a cutting tool. A high-pressure injection injury is a surgical emergency. Seek immediate medical treatment for all high-pressure waterjet injuries. Delayed treatment can cause serious injuries or death.
 WARNING	Do not touch a hot surface.
 WARNING	Personal protective equipment is recommended. Failure to wear personal protective equipment can cause injuries or death.
	Keep the work area clean and free of fluid spills.

Hypertherm products are designed and manufactured with a commitment to continuous quality control and safety. Contact a Hypertherm Technical Service Associate for information and support regarding the installation, operation, maintenance, and repair of this equipment.

Buyer obligations

 CAUTION	This pump is capable of generating water pressure of up to 4,137 bar or 413,685 kPa (60,000 psi). Only use high-pressure tubing that is rated for this pressure.
 CAUTION	Support all plumbing to prevent bending stress and fatigue from vibration. A disruption or crack in plumbing can cause injuries to people or damage to equipment.

 Hypertherm does not always ship the pump with hydraulic fluid in the tank. It is the buyer's responsibility to fill the tank with hydraulic fluid.

The buyer is responsible for these obligations:

- Cooperate with Hypertherm and the Hypertherm original equipment manufacturer (OEM) regarding the installation of the equipment.
- Research and comply with all local codes, including requirements for wastewater disposal.
- Install high-pressure tubing.
- Install water-treatment equipment before the pump is installed.
- Make sure that all utilities are available during installation. The site must have sufficient electrical power, air, water, and sewer drain access.
- Make all connections to the pump.
- Perform user qualification and training. Refer to **User qualification and training** on page 20 for more information.



Seller obligations

If Hypertherm Inc. installs the equipment, some or all of these tasks are the responsibility of the Hypertherm technician as defined in the sales agreement.

- Make sure that the buyer understands all buyer obligations.
- Make sure that the site is prepared for installation.
- Make sure that all utility connections are correctly routed.
- Follow all setup and first-time startup instructions in this manual.
- Provide training for maintenance and repair procedures.
- Follow standard system acceptance tests.

Requirements



Location

 WARNING	Some locations can be hazardous if the atmosphere contains gas, vapors, or dust in explosive quantities. Refer to requirements from the National Electric Code (NEC), the International Electrotechnical Commission (IEC), and the Occupational Safety and Health Administration (OSHA), as well as local codes for detailed information about environmental criteria.
 CAUTION	When work must be done in confined spaces with limited access, the access must not be blocked by ventilation ducts, hoses, pipes, or other equipment.

Put the equipment on a flat surface, such as concrete, that is capable of supporting the weight of the pump and thick enough to resist vibration. The feet on the frame can be adjusted to level the pump.

Make sure that there is a minimum clearance of 91 cm (36 inches) on all sides of the equipment to permit air movement for efficient cooling and room for maintenance and repair.



Temperature

	Do not install this equipment in an environment where the temperature is below freezing. Freezing can cause severe damage to low-pressure and high-pressure water parts.
	Equipment installed in a hot location can require a larger external air cooler. Contact the OEM or a Hypertherm Technical Service Associate for assistance.

Ambient temperature has an effect on cooling. Supplementary cooling is usually necessary for a pump confined to a small, high-temperature space.

 For temperature requirements, refer to the **Pump specifications**, which begin on page 173.



Electrical power

 DANGER	Dangerous voltage To reduce the risk of serious injuries or death, wear approved protection and follow safety recommendations when working with electricity.
 WARNING	Make sure that a line disconnect switch for incoming electrical power is installed near the power supply to serve as a supply-voltage disconnecting or isolating device.
	Make sure that the primary feed protection device (circuit breaker or fuse) is sized to handle inrush and steady-state current. Use a motor-start circuit breaker or an equivalent if time-delayed high-inrush fuses are not permitted by local or national codes.

The motor size determines the full load amperes, the overload settings, and the wire sizes. Refer to the technical drawings for more information.

 The electrical power requirements are on the data plate on the rear of the pump and on the inside of the electrical enclosure door.

Water

	Do not use deionized water unless the system has stainless steel water fittings. Using deionized water in standard systems can cause the plumbing parts to fail and causes substantially shorter consumable life.
	Check local codes to determine if a backflow prevention valve is required to separate the pump from the facility's potable water.
	If the cooling water or the low-pressure water temperature is higher than 23.9°C (75°F), cool the water before use. Water that is too warm is inefficient for cooling and can reduce high-pressure seal life.

 For minimum and maximum flow, pressure, and temperature requirements, refer to the **Pump specifications**, which begin on page 173.

Water quality

The quality of the water supplied to the intensifier has a direct effect on the life of the pump. Poor water quality increases operating costs by causing unnecessary wear on pump parts and shortening maintenance intervals.

Before installing this equipment, do a water quality analysis. Water quality reports that show pH, silica, and hardness levels are frequently available for no charge from public utility water suppliers.

Total suspended solids (TSS)

Suspended solids refers to small, solid particles that are suspended in water. Filters are used to remove these solids. Hypertherm pumps include filters that remove TSS from the cutting water.

Total dissolved solids (TDS)

Dissolved solids refers to molecular, ionized, or microgranular particles in solution in water. TDS include hard elements such as iron, calcium, magnesium, and silica, which form deposits on the inside of high-pressure plumbing and can damage check valves, seals, orifices, and other consumables.

 Most systems require softened water. Consult a specialist for recommendations for choosing a water treatment system. Reverse osmosis systems are available from Hypertherm.

Test the water quality

Public utility water and well water quality can change. Hypertherm recommends regular testing.

 Some TDS meters require calibration before use. For best results, calibrate the meter at 25.0°C (77°F). Refer to the instructions supplied with the TDS meter.

 If multiple readings are taken, turn the meter OFF between readings.

9 – Installation



Required parts, tools, and materials

- pH tester
- Silica test kit
- Water hardness (calcium carbonate) test kit
- 13897 TDS meter
- Container for water sample

1. Collect a sample of water. Make sure that the water is clear, odorless, and free of biological materials.
2. Test the pH. The ideal pH measurement is between 6.0 and 8.0.
3. Test the silica (SiO_2) content. The silica content must be less than 0.0015% (15 parts per million [ppm]).
4. Test the water hardness. The result must be equal to or less than 0.006% (60 ppm).
5. Test the TDS concentration. The ideal range is 0.005% to 0.015% (50 ppm to 150 ppm).
 - ❑ A TDS level that is less than 0.005% (50 ppm) can harm waterjet parts and requires the use of nonmetallic or stainless steel fittings.

 CAUTION	A TDS value of less than 0.0005% (5 ppm) can damage stainless steel parts.
--------------------	--

- ❑ Treat water with a TDS level that is more than 0.015% (150 ppm) with reverse osmosis or consider using deionized water.

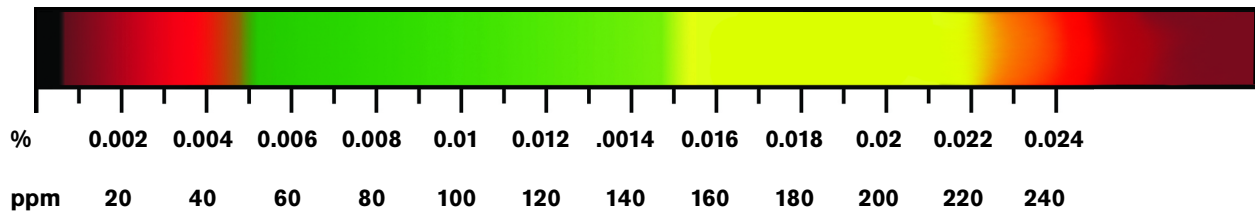

Unacceptable	Ideal	Acceptable	Unacceptable
less than 0.005% (50 ppm)	0.005% to 0.015% (50 ppm to 150 ppm)	0.015% to 0.022% (150 ppm to 220 ppm)	more than 0.022% (220 ppm)
Use nonmetallic or stainless steel fittings.	—	Consider using a reverse osmosis system to remove TDS.	Use a reverse osmosis system to remove TDS.

Receive and unpack the equipment

Unload the pump



Misuse of lifting equipment can cause the load to become unstable, which can cause property damage, personal injury, or death.

Lifting must be done by a trained operator. Follow all work site-safety requirements, the safety instructions for the lifting equipment, and the safety information in this manual.

- Examine the pallet for cracks or damage.
- Test the hydraulic controls on the lifting equipment before picking up a load.
- Refer to the operation instructions for the lifting equipment.

Unpack the pump



Boxes and parts are frequently packed inside the pump, or in crates, boxes, and packaging. Look for accessories and spare parts before discarding the packaging.

1. Remove the equipment from the shipping pallet. Use the leveling feet to level the pump on a flat surface.
2. Make sure that these items are included and complete.
 - Basic tool kit (optional)
 - Basic spare parts kit (optional)
This kit is usually inside the case for the basic tool kit.
 - The key for the LOCAL/REMOTE key switch
This is usually shipped inside the electrical enclosure.
 - A copy of the system schematic drawing
This is usually shipped inside the electrical enclosure.
3. Inspect the equipment to make sure that it was not damaged during shipping. If the equipment is damaged, a claim must be filed with the carrier.
4. Make sure that the delivery and shipping documents match the equipment that was ordered and what was received. Report shortages or damages to the OEM or to Hypertherm Waterjet within 10 days of receipt of the equipment.



For easy reference, write the pump information on the **Pump information** page at the front of this manual.

Make the connections for remote operation

 Remote operation is optional.

 All controls are 24-volt direct current (VDC).

These tables show the remote connections from a user panel or a computer numerical control (CNC) operator console. Refer to **Operate the pump remotely** on page 66 for details about these controls.

Remote emergency stop

The OEM or the system integrator is responsible for connecting the emergency stop.

The terminals are in series with the emergency stop circuit. The terminals are wired to dry contacts on the emergency stop at the remote control source.

If the pump is set up to run remotely and has a motion system (robot or cutting table), the emergency circuits from the robot or cutting table can be in series with the local emergency stop circuit.

	Wire number	Type of contact
Operation	5024A	Normally closed
Status	5024A	Normally closed
Discrete pressure input	6022, 6022A	Input, maintained, normally open
Remote mode active indicator	6027, 24COM	Output
Remote pump fault indicator	7004, 24COM	Output
Remote pump run indicator	6047, 24COM	Output
Controls on indicator	5024C	Output

Remote controls on

If the pump is off, this turns on the primary control relay.

	Wire number	Type of contact
Operation	6027, 5024A	Momentary, normally open
Status	6027, 5024A	Momentary, normally open

9 – Installation

Remote pump on

If the pump is off, this input performs a sequential startup of the pump.

If the pump is running in cooling mode, this input causes the intensifier to start stroking.

	Wire number	Type of contact
Operation	6028	Input, momentary, normally open
Status	6028	Input, momentary, normally open
Emergency stop	5024A, 5024B  A jumper is installed between these terminals at the factory.	Normally closed

Remote pump off

This input turns off the intensifier, the boost pump, the primary motor, the low-pressure water, and the cooling fan.

	Wire number	Type of contact
Operation	6029	Input, momentary, normally closed
Status	6029	Input, momentary, normally closed

Remote low pressure

This input permits the operator to put the pump in pierce-pressure mode.

	Wire number	Type of contact
Emergency stop	6031	Input, momentary or maintained, normally open

Remote cooling on

This input turns on the fan motor and the cooling water or the cooling fan logic, and turns off the intensifier.



	Wire number	Type of contact
Emergency stop	6030	Input, momentary or maintained, normally open

Install the external air cooler



An air cooler is an option for air-cooled systems.



Make sure that there is a minimum clearance of 91 cm (36 inches) in the front and rear of the air cooler to permit enough air flow for efficient cooling.

1. Use the attached mounting bars to secure the air cooler to the ground or on an elevated platform.
2. The air cooler includes 2 hydraulic hoses that are approximately 9 m (30 feet) long. Connect 1 end of each hose to the top and bottom ports on the air cooler.
3. Connect the 4-conductor cable from the air cooler motor to the panel in the electrical enclosure.
 -  The full load amperes, overload settings, and wire sizes are different, depending on the motor size.
 -  For more information, refer to the system schematic drawing.
4. Push the cable through the cord grip connector in the electrical enclosure.
5. Connect the cable to the motor starter–contactor.

Make the connections to the utility panel fittings

 CAUTION	Do not couple the WASTEWATER OUT and the COOLING OUT lines. Coupling these lines can cause cooling water to back up into the system, which can cause damage to the bleed-down valve and the intensifier parts.
 CAUTION	Air-cooled systems must be connected to the external air cooler before starting the motor. Failure to connect the COOLING IN and COOLING OUT lines can damage the hydraulic hoses, the hydraulic filter, or the air cooler.

These fittings are found on the utility panel on the rear of the pump.

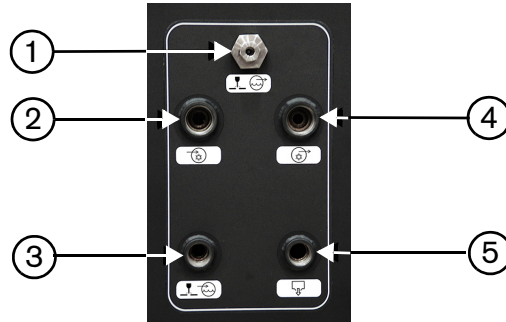

- 1 CUTTING WATER OUT
- 2 COOLING IN
- 3 CUTTING WATER IN

- 4 COOLING OUT
- 5 WASTEWATER OUT















Required parts, tools, and materials

- 13/16-inch open-ended wrench
- 1-1/2-inch open-ended wrench
- 5/8-inch open-ended wrench
- 1/4-inch NPT male connector
- Two 3/4-inch NPT male connectors
- 3/8-inch high-pressure female connector
- Two -16 JIC female connectors (for an air-cooled system)
- Two 1-inch NPT male connectors (for a water-cooled system)

9 – Installation





1. Remove the caps and the covers from the fittings on the utility panel.
2. Connect the water lines.

 <p>WASTEWATER OUT</p>	<p>3/4-inch NPT male connector</p>	<p>This line carries water from the bleed-down valve and the low-pressure system to a drain.</p> <ul style="list-style-type: none">  Install the wastewater plumbing so that it is lower than the fitting on the pump to prevent contaminated water from entering the bleed-down valve.  Use a flexible hose instead of a pipe to make troubleshooting easier.
 <p>CUTTING WATER IN</p>	<p>3/4-inch NPT male connector</p>	<p>Connect this line to the supply water.</p> <ul style="list-style-type: none">  If the supply water is treated by reverse osmosis, the boost pump settings can require adjustment. Contact a Hypertherm Technical Service Associate for assistance.
 <p>COOLING IN</p>	<p>Water-cooled system 1-inch NPT male connector</p>	<p>Connect this line to the supply water supply or to the chiller.</p> <ul style="list-style-type: none">  Public utility water is usually sufficient. If the public utility water has a high mineral content, prefiltering or softening might be necessary to prevent deposits from clogging the plates or tubes in the heat exchanger. Refer to the Water quality section, which begins on page 188.
	<p>Air-cooled system -16 JIC female connector</p>	<p>Connect this hose to the top fitting on the external air cooler. This hose carries hydraulic fluid.</p> <ul style="list-style-type: none">  Air-cooled systems are shipped with caps on the COOLING IN and COOLING OUT connectors. Remove these caps before connecting the pump to the external air cooler.
 <p>COOLING OUT</p>	<p>Water-cooled system 1-inch NPT male connector</p>	<p>Connect this line to the drain or to the chiller return.</p>
	<p>Air-cooled system -16 JIC female connector</p>	<p>Connect this hose to the bottom fitting on the external air cooler. This hose carries hydraulic fluid.</p> <ul style="list-style-type: none">  The connection on the heat exchanger is usually marked INLET.  Air-cooled systems are shipped with caps on the COOLING IN and COOLING OUT connectors. Remove these caps before connecting the pump to the external air cooler.
 <p>CUTTING WATER OUT</p>	<p>3/8-inch high-pressure female connector</p>	<p>Connect a high-pressure plumbing line from this fitting to the waterjet cutting table.</p>

Add hydraulic fluid

Some pumps are shipped without hydraulic fluid. Make sure that hydraulic fluid is available during installation and startup. Refer to **Add hydraulic fluid** on page 78 for instructions.

Connect the electrical power

 WARNING	A line disconnect switch for incoming electrical power must be installed near the power supply to serve as a supply-voltage disconnecting (isolating) device.
 WARNING	The primary incoming electrical power must be installed by a licensed electrician and must be in compliance with all applicable codes.
 CAUTION	The primary feed protection device (circuit breaker or fuse) must be sized to handle inrush and steady-state current. Use a motor-start circuit breaker or an equivalent if time-delay high-inrush fuses are not permitted by local or national codes.
 	When connecting electrical power to this equipment, it is the buyer's responsibility to investigate and comply with all local codes.
 	Use electrical parts that are certified by national or local electrical codes.

 The voltage, frequency, full load amperes, overload settings, and wire sizes differ depending on the pump size.

 Pumps equipped for certain foreign electrical power can have different connection requirements. For connection information, refer to the system schematic drawing.

 Some pump models have a knockout at the bottom of the electrical enclosure for routing electricity into the enclosure.







 Power requirements are found on the data plate on the back of the pump and on the inside of the electrical enclosure door.

1. Connect the electrical supply to the primary circuit breaker. This breaker is identified on the technical drawing and inside the electrical enclosure as MAIN C.B.
2. Attach a ground leg to the grounding lug inside the electrical enclosure. Use this table to find the minimum cross-sectional area of the external copper ground leg.

If the cross-sectional area (S mm ²) of the copper phase conductors supplying the equipment is	The minimum cross-sectional area (S_p mm ²) is
equal to or more than 16	equal to S
more than 16 and less than or equal to 35	16
more than 35	$S/2$

 HyPrecision pumps can leak up to 160 mA. To reduce the effects of a high leakage current, connect the pump to a dedicated supply transformer that has separate windings.

Do the first startup

 WARNING	Do not leave waterjet cutting equipment turned on and unattended.
 CAUTION	Air-cooled systems must be connected to the external air cooler before starting the motor. Failure to connect the COOLING IN and COOLING OUT lines can damage the hydraulic hoses, the hydraulic filter, or the air cooler.
 CAUTION	If a water line, fitting, or valve might be frozen, do not operate the pump. Thaw the equipment until water moves freely through the entire water circuit.
	High-pressure water can cause eye injuries. Wear approved eye protection when operating or working near this equipment.
	This waterjet equipment might exceed national and local codes for permitted noise levels. When this pump is running, the noise level is 75 dB(A) to 80 dB(A). Noise level is related to factors such as water flow rate, pipe layout, and the acoustical characteristics of the building. Prolonged exposure to noise can cause permanent hearing loss. Wear approved ear protection and control exposure time when operating or working near this equipment.
	High-pressure water can cause severe cuts or lacerations, abrasions, and punctures. Wear approved hand protection when operating or working near this equipment.

Use this procedure at installation and after maintenance or repairs are done on the intensifier, the high-pressure water system, or the low-pressure water system.

Do a preoperation inspection



 CAUTION	Make sure that all connections are tight before operating this equipment.
---	---

Examine the equipment before starting the pump.

- Look for leaks, deterioration, damage, or other conditions that can interfere with operation.
- Look at the sight gauge on the hydraulic fluid tank. If necessary, add hydraulic fluid.
- Close all doors and replace all covers, including access covers.

Turn on the utilities

1. Turn ON the electrical breaker.
2. Turn ON the water. Monitor for leaks. Identify the source of a leak and correct the problem. Refer to **Leaks** on page 163.



 WARNING	Do not attempt to repair a leak with pressure in the system.
 WARNING	Use a piece of cardboard or other solid material to check for leaks when the pump is on. Do not use hands, cloth, paper, or towels.

3. Make sure that the primary breaker disconnect lever on the electrical enclosure door is set to ON.
4. Turn ON the electrical power.

Change the system configuration on the operator interface

A password-protected system configuration menu permits the operator to change the language and to change between psi and bar on the operator interface. Contact a Hypertherm Technical Service Associate for assistance.

Start the pump

 WARNING	This procedure involves exposing a rotating shaft. Do not put an object or a body part near the shaft while it is exposed. Be prepared to push the EMERGENCY STOP button.
	Do not do the first startup with a diamond orifice installed. The likelihood of damaging the orifice during the first startup is very high.

 Hypertherm recommends using a ruby orifice during the first 40 hours of operation.

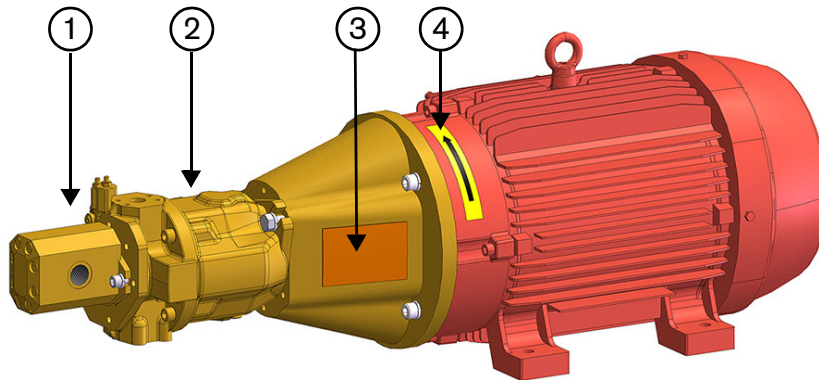

- | | |
|--------------------------|--------------------------------|
| 1 Gear pump | 3 Shaft access cover |
| 2 Primary hydraulic pump | 4 Primary motor rotation arrow |



1. Remove the shaft access cover.
2. Set the pierce pressure to its minimum by turning the pierce-pressure control knob all the way to the left (anticlockwise).
3. Make sure that the LOCAL/REMOTE key switch on the operation panel is set to LOCAL.
These events occur when the key switch is set to LOCAL:
 - The operator interface is used to run the pump.
 - The REMOTE ACTIVE indicator light is off.
 - The operator interface is the primary point of control.
4. Push the CONTROLS ON button to turn ON the control circuit inside the pump.

 The pump can not be turned on until the control circuit is on.

5. Turn OFF the cutting head.
6. Turn ON the pump in cooling mode.

9 – Installation

7. Make sure that the motor turns in the direction shown by the arrow on the motor mount.

 CAUTION	<p>Make sure that the primary motor rotates in the correct direction before starting the pump. The pump shaft must turn in the direction shown by the motor rotation arrow.</p> <p>Reverse rotation of the pump can unscrew the impeller and cause permanent damage to the hydraulic pump and its parts.</p>
 CAUTION	<p>To prevent catastrophic damage to the pump parts, connect the hydraulic lines between the pump and the external air cooler before checking the motor direction on an air-cooled system.</p>

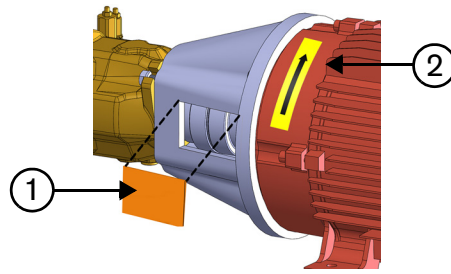

1 Shaft access cover

2 Motor direction arrow

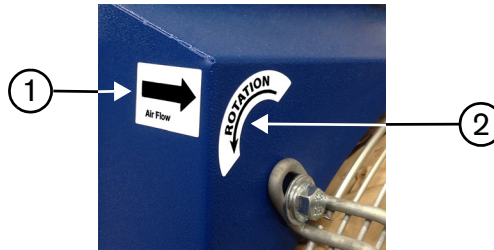

8. If the pump has an external air cooler, make sure that the fan motor turns in the direction shown by the arrow.



1 Fan direction arrow

2 Airflow direction arrow

9. If the pump motor or the fan motor turns in the wrong direction, follow these instructions:
- Push the EMERGENCY STOP button.
 - Disconnect the electrical power.
 - In the electrical enclosure, trade the 2 incoming leads on the primary circuit breaker for the motor that is turning the wrong direction.
 - Make sure that the motor rotates in the correct direction.
10. Let the pump run for 2 to 3 minutes. Monitor for leaks. Identify the source of a leak and correct the problem. Refer to **Leaks** on page 163.

 WARNING	<p>Do not attempt to repair a leak with pressure in the system.</p>
 WARNING	<p>Use a piece of cardboard or other solid material to check for leaks when the pump is on. Do not use hands, cloth, paper, or towels.</p>

11. Push the filter purge buttons until water comes out from under each button.

9 – Installation

12. Touch the pierce-pressure mode symbol.
13. To remove air from the high-pressure lines, turn ON the cutting head. When water comes out of the cutting head, turn it OFF.



The pump is on standby when the cutting head is turned off. The hydraulic pressure stays at the set pressure and the intensifier does not stroke. When the cutting head is turned on, the intensifier strokes.

14. Slowly increase the pump pressure. Refer to page 51 for instructions.
15. Make sure that the value on the prefilter water-pressure gauge is between 3.45 bar and 7.93 bar or 345 kPa and 793 kPa (50 psi to 115 psi). If the pressure is not in this range, adjust the boost pump pressure.

Adjust the boost pump pressure



When the low-pressure water is supplied from a tank, such as water from a reverse osmosis system, it is frequently necessary to increase the pressure.

The boost pump operates with a supply water pressure of 2.76 bar to 4.8 bar or 275.8 kPa to 482.63 kPa (40 psi to 70 psi), increasing the water pressure to 7.85 bar or 758 kPa (110 psi).

Do this task when the pump is not running.

1. Open the water valve to drain the water from the system. Make sure that the value on both water-pressure gauges is 0.0 bar or 0 kPa (0 psi).
2. Loosen the jam nut on the bypass relief valve.
3. Turn the T-handle adjustment screw clockwise to increase pressure or anticlockwise to decrease pressure.
4. Close the water valve.
5. Turn ON the pump in cooling mode.
6. Make sure that the value on the prefilter water-pressure gauge is between 3.45 bar and 7.93 bar or 345 kPa and 793 kPa (50 psi to 115 psi). If the pressure is not in this range, repeat the procedure.
7. Tighten the jam nut on the bypass relief valve.

Flush the pump and the high-pressure tubing

 WARNING	Do not operate the pump without the shaft access cover and all other safety devices correctly installed. Do not remove guards while the pump is operating.
 CAUTION	It is common for small pieces of metal and debris to be present in newly installed high-pressure tubing. Flush the system to prevent damage to orifices, on/off valve parts, and other parts of the high-pressure system.

Follow this procedure after replacing or repairing high-pressure tubing and fittings.

 This procedure identifies 1 method to flush out the high-pressure lines. If this pump was purchased through an OEM, the OEM might recommend a different procedure.

 This procedure can cause damage to the on/off valve sealing parts and orifices. Keep spare kits and orifices available.

1. Remove the cutting head and the orifice.
2. Make sure that the on/off valve is closed.
3. Turn ON the pump in cooling mode. Permit the pressure to stabilize.
4. Make sure that the hydraulic pressure is at or less than 34 bar or 3,447 kPa (500). If the pressure is higher than 34 bar or 3,447 kPa (500 psi), contact a Hypertherm Technical Service Associate for assistance.
5. Change the pump to cut-pressure mode. The intensifier strokes until the pump reaches the cut-pressure setting and then it stops stroking.
6. Turn the cut-pressure control knob until the hydraulic pressure is 34.47 bar or 3447 kPa (500 psi).
7. Use the CNC control to make a program that turns the valve ON and OFF in 1-second increments. Run the program in a loop for 15 minutes.

If the CNC control is not available, turn the head ON and OFF in 1-second intervals for 15 minutes. This shocks the high-pressure tubing and frees debris in the tubing.

 Debris can cause damage to the on/off valve needle and the seat. If this occurs, attempt to complete this procedure by removing debris from the parts rather than replacing the parts right away.

8. Increase the pierce pressure to 69 bar or 6,895 kPa (1,000 psi). Run the program in a loop for 15 minutes.
9. Install a ruby orifice in the cutting head. For orifice sizes, refer to the **Pump specifications** section, which begins on page 173. Run the program in a loop for 15 minutes.
10. Increase the pierce pressure to 138 bar or 13,790 kPa (2,000 psi). Run the program in a loop for 15 minutes.
11. Increase the pierce pressure to 207 bar or 20,684 kPa (3,000 psi). Run the program in a loop for 15 minutes.
12. Examine the on/off valve needle, the seat, the seals, and the orifices for damage. Replace these items if necessary.